



Platinum Foundation Managed

**GANDHINAGAR INSTITUTE OF TECHNOLOGY**

Approved by AICTE, Affiliated: Gujarat University and Gujarat Technological University

[About Us](#)

[Editorial Board](#)

[GIT Trustees](#)

[Editorial GIT JET](#)

[Message](#)

[Content](#)

[Contact Us](#)



## About Gandhinagar Insitute of Technology

Gandhinagar Institute of Technology was established by Platinum Foundation Trust in December 2006. The Institute is affiliated to Gujarat Technological University and Gujarat University and approved by AICTE New Delhi. The Trust is registered under Public Trust Act, having Registration No. E-17490 dated 19 June 2006 at Ahmedabad, Gujarat.

The Institute aims to be a leading center for research and engineering study, pursuing knowledge in both fundamental and applied area, and collaborating closely with business and industry in promoting technological innovation and economic development. The members of the Trust are involved in social activities and are also contributing to the technical institutions development by raising funds and promoting the technical interest of state and country. Gandhinagar Institute of Technology is situated near Village "Moti Bhoyan" and 24 km away from Ahmedabad city.

It offers B.E Program in Mechanical, Electronics & Communication, Computer Engineering & Information Technology and Civil Engineering. It also offers MBA Program with specialization in Marketing, Finance, Human Resource Management and Information Systems. Gandhinagar Institute of Technology will nurture the intellectual growth of its students and serve humanity through creation, application and dissemination of knowledge relevant to technology and become one of the premier Engineering and Management Institutes and achieve the highest order of excellence in teaching.

## **EDITORIAL BOARD**

- Prof. M. N. Patel* : Principal, L. D. College of Engineering and  
Dean, Faculty of Engineering and Technology  
Gujarat University, Ahmedabad  
Acting Vice-Chancellor, Gujarat Technological University
- Dr. F. S. Umarigar* : Principal, BVM Engineering College and  
Dean, Faculty of Engineering and Technology,  
University, V V Nagar
- Dr. S. A. Puranik* : Director, Atmiya Institute of Science and Technology, Rajkot
- Dr. Ketan Kotecha* : Director, Institute of Technology, Nirma University  
Ahmedabad
- Dr. P. K. Shah* : Director, Silver Oak College of Engineering & Technology  
S.G. Highway, Ahmedabad
- Dr N M Bhatt* : Chairman & Convenor  
Principal, Gandhinagar Institute of Technology,  
Moti Bhojan, Ta. Kalol, Dist. Gandhinagar

### **Disclaimer**

Views expressed in the papers are solely from respective authors and editorial board has no responsibility of their authentication

This journal is being published in the interest of research community for private circulation only

[About Us](#)[Editorial Board](#)[GIT Trustees](#)[Editorial GIT JET  
Message](#)[Content](#)[Contact Us](#)

## GIT Trustee's

GIT Trustee's

**Shri Harishbhai B. Rohera****Qualifications** : B. Com**Position** : Member - Board of Trustee & Advisory Board**Background**

- » Proprietor: Mahadev Steel Suppliers
- » C/o: Vinayak Steel Syndicate
- » C/o: Dhiraj Steel Supplier
- » C/o: Krishna Steel Trader
- » Owner: National Steel Processor
- » Trustee: Sai Vasant Ghot Darbar
- » Trustee: Jai Jhulelal Mandir

**Shri Dipakbhai N. Ravani****Qualifications** : B.Com., LL.B.**Position** : Member - Board of Trustee & Advisory Board**Background**

- » Business

**Shri Pravinbhai A. Shah****Qualifications** : B.A., LL.B.**Position** : Member - Board of Trustee & Advisory Board**Background**

- » President of Zalavad Samaj Jain Seva Trust
- » Trustee of Vasant Atma Charitable Trust
- » Trustee of Rampura Champa Vijya Hospital
- » Trustee of Shantivan & Ambawadi Jain Sangh
- » Trustee of Rampura Kelavani Mandal
- » Trustee of Pampura Panjrapole Trust

**Shri Gahanshyambhai V. Thakkar****Qualifications** : M.A**Position** : Member - Board of Trustee & Advisory Board**Background**

- » Professor at Vivekanand College of Arts, Ahmedabad
- » Ex. M.L.A., Gujarat Assembly from Mandal
- » Trustee of V.M. Thakkar Charitable Trust, Ahmedabad
- » Manages Muktajeevan Vidhyalaya and BVD High School, Isanpur and Maninagar

- » Advisor/Member Kankaria Maninagar Nagarik Sahakari Bank
- » Director - Adarsh Co-Operative Departmental Stores

**Smt Varshaben M. Pandhi****Qualifications** : B.Com**Position** : Member - Board of Trustee & Advisory Board**Background**

- » Working experience in the field of Insurance and Investment Advisory for about 20 years

## Research Methods

**Research** is another word for gathering of information. The more information we have the closer we get of making our own decision. Research is the result of advancing knowledge created in the past. There are people from all walks of life that contribute to gathered information. These are ordinary people and extraordinary people. They include teachers, students, scientists, professors, scholars, business owners, librarians, book keepers, writers, politicians and many more unknown out there.



Research is designed to solve a particular existing problem so there is a much larger audience eager to support research that is likely to be profitable or solve problems of immediate concern. We also must understand how research impacts our decision making. Most people make decisions without gathered information to back them up. Only few do. Research requires time, effort, and sometimes money to have the evidence you need to make a sound decision that's why many avoid it. The research you do and evidence you gathered will have impact on your future. Be advised, considered the risks or consequences of making an important decision with inadequate evidence.

In conclusion research is very vital to our everyday decision making. It arms you from wrong information and save time and money. It is important to your success as you take on life's challenges and career decisions making. But be careful though, because too much research without action on what you're learning is not good either. The question is how much information is enough? How much information can you afford? Research plus action will most likely guarantee a successful research.

There are five fundamental research methods viz. (1) Experimental methods (2) Correlations (3) Naturalistic observation (4) Survey and (5) Case Study.

**Experimental Methods:** This method is one in which a researcher manipulates a variable (anything that can vary) under highly controlled conditions to see if this produces (causes) any changes in a second variable. The variable, or variables, that the researcher manipulates is called the independent variable while the second variable, the one measured for changes, is called the dependent variable. Independent variables are sometimes referred to as antecedent (preceding) conditions. All scientific disciplines use this method because they are interested in understanding the laws (cause-and-effect relationships) of nature. The power of the experimental method derives from the fact that it allows researchers to detect cause-and-effect relationships.

In order to see cause-and-effect relationships the researcher must be sure that his manipulations (the independent variable) are the only variables having an effect on the dependent variable. He does this by holding all other variables, variables that might also affect the dependent variable, constant (equivalent, the same). Only by this highly controlled procedure can the researcher be sure that the observed changes in the dependent variable were in fact caused by his manipulations. Experimental studies, therefore, are used when the researcher is interested in determining cause-and-effect relationships. Also, this method can be used when it is appropriate, both practically and ethically, to manipulate the variables.

However, a major limitation is that this method can only be used when it is practical and ethical for the researcher to manipulate the antecedent conditions. A second limitation to this method is that experimental studies are usually done in the highly controlled setting of the laboratory. These conditions are artificial and may not reflect what really happens in the less controlled and infinitely more complex real world.

**Correlations:** Correlation is classified as a non-experimental, descriptive method. The reason for that is because variables are not directly manipulated as they are in the experimental method. Although correlation is often described as a method of research in its own right, it is really more of a mathematical technique for summarizing data, it is a statistical tool. A correlational study is one designed to determine the degree and direction of relationship between two or more variables or measures of behavior.

The strength of this method lies in the fact that it can be used to determine if there is a relationship between two variables without having to directly manipulate those variables. In other words, correlation can be used when the experimental method cannot; correlation can be used when it is impractical and/or unethical to manipulate the variables. Correlation also can be used as a basis for prediction.

The greatest limitation of correlation is that it does not tell researchers whether or not the relationship is causal. In other words, correlation does not prove causation. It only shows that two variables are related in a systematic way, but it does not prove nor disprove that the relationship is a cause-and-effect relationship. Only the experimental method can do that.

**Naturalistic observation:** The naturalistic observation is a type of study classified under the broader category of field studies; non-experimental approaches used in the field or in real-life settings. In the naturalistic observation method the researcher very carefully observes and records some behavior or phenomenon, sometimes over a prolonged period, in its natural setting. The subjects or phenomena are not directly interfered with in any way. In the social sciences this usually involves observing humans or animals as they go about their activities in real life settings. In the natural sciences this may involve observing an animal or groups of animals or some physical phenomena, such as the eruption of a volcano.

The major strength of this method is that it allows researchers to observe behavior in the setting in which it normally occurs rather than the artificial and limited setting of the laboratory. Further uses might include studying nature for its own sake or using nature to validate some laboratory finding or theoretical concept.

One of the limitations is that this is a descriptive method, not an explanatory one. That is, without the controlled conditions of the laboratory, conclusions about cause-and-effect relationships cannot be drawn. Behavior can only be described, not explained. This method can also take a great amount of time. Researchers may have to wait for some time to observe the behavior or phenomenon of interest. Further limitations include the difficulty of observing behavior without disrupting it and the difficulty of coding results in a manner appropriate for statistical analysis.

**Survey:** The survey, another type of non experimental, descriptive study, does not involve direct observation by a researcher. Rather, inferences about behavior are made from data collected via interviews or questionnaires. Interviews or questionnaires commonly include an assortment of forced-choice questions (e.g. True-False) or open-ended questions (e.g. short answer essay) to which subjects are asked to respond. This sort of data collection is sometimes referred to as a self-report. Surveys are particularly useful when researchers are interested in collecting data on aspects of behavior that are difficult to observe directly and when it is desirable to sample a large number of subjects. Surveys are used extensively in the social and natural sciences to assess attitudes and opinions on a variety of subjects.

The major limitation of the survey method is that it relies on a self-report method of data collection. Intentional deception, poor memory, or misunderstanding of the question can all contribute to inaccuracies in the data. Furthermore, this method is descriptive, not explanatory, and, therefore, cannot offer any insights into cause-and-effect relationships.

**Case study:** This method is also a non-experimental, descriptive type of study. It involves an in-depth descriptive record, kept by an outside observer, of an individual or group of individuals. This often involves collecting and examining various observations and records of an individual's experiences and/or behaviors. Typical data collected might include biographical data, medical records, family history, observations, interviews, and the results of various psychological tests.

Case studies are particularly useful when researchers want to get a detailed contextual view of an individual's life or of a particular phenomenon. Case studies are also useful when researchers cannot, for practical or ethical reasons, do experimental studies.

This is a descriptive method, not an explanatory one. That is, without the controlled conditions of the laboratory, conclusions about cause-and-effect relationships cannot be drawn. Behavior can only be described, not explained. Case studies also involve only a single individual or just a few and therefore may not be representative of the general group or population. Also, much of the information collected is retrospective data, recollections of past events, and is therefore subject to the problems inherent to memory.

Dr N M Bhatt  
Principal

[About Us](#)[Editorial Board](#)[GIT Trustees](#)[Editorial GIT JET](#)[Message](#)[Content](#)[Contact Us](#)

Sr.	Title of Papers	Author	Institution	E-mail ID
1	<a href="#">Airo Static Stability Analysis of Long Span Suspension Bridges</a>	Prof. Niraj shah Associate professor and head	Charotar Institute of Technology, Changa	nirajshah.cv@ecchanga.ac.in
2	<a href="#">Flooding in Computer Network With Passive Clustering</a>	Mrs. Darshana Mistry	Computer Engineering Dept., Gandhinagar Institue Of Technology, Gandhinagar	darshana.mistry@git.org.in
3	<a href="#">Ann Based Intelligent Controllers For An Indirect Vector Controlled Three-Phase Induction Motor</a>	Ami Patel, Assistant professor Tejendra Patel, Surat P.G. Student	SVNIT, Surat	ami_engg86@yahoo.com ami.mgiter@gmail.com
4	<a href="#">Comparative Study of Web Services and Software oriented Architecture for Mobile Augmented Reality System</a>	Jatin Shah, MCA, Research Scholar, DR. Bijendra Agrawal Principal	VKMS College, Vadu	jatinshah79mca@gmail.com, bijendra_agrawal@yahoo.com
5	<a href="#">QUEST (Quick Unbiased Efficient Statistical Tree): An efficient algorithm of Classification Tree in Data Mining</a>	Mr. U. N. Parmar, Mr. A. K. Ranpura, Mr. V. K. Jadeja, Mr. R. P. Joshi	CCET, Wadhwan, Gujarat.	ureshparmar13@yahoo.co.in, vkjadeja_itworld@yahoo.co.in, rah1985@gmail.com
6	<a href="#">Performance Analysis of Gun-shot Direction Detection System for ak47 gun shot</a>	Anju M. Vasdewani Dr. G.R.kulkarni R.S.Gajre	C.U.Shah College of Engineering & Technology, Wadhwan City	grkulkarni29264@rediffmail.com rakeshgajre@gmail.com
7	<a href="#">Modified Bagging Method: A Novel Approach of Multiple Classification in Data Mining</a>	Mr. Uresh N Parmar Mr. Krunal G Patel, Ms Meenakshi	C.C.E.T, Wadhwan, Gujarat, India	ureshparmar13@yahoo.co.in kgp2003@gmail.com meenakshi.saroaha@gmail.com
8	<a href="#">Emission Scenario At Road Intersections - A Case Study Of Surat City</a>	Jayesh A. Shah Dr.F.S.Umrigar Dr L.B.Zala, Neeraj D.Sharma	V.B.T.Engg. College, Umrakh B.V.M Engg. College, V.Vidyanagar	
9	<a href="#">Performance Comparison of Space Time Codes</a>	Mrs. Anshu Shah	Gandhinagar Institue Of Technology, Gandhinagar	anshu.shah@git.org.in
10	<a href="#">Data Mining: Terms And Techniques</a>	Mr. Uresh N Parmar, Mr. Krunal G. Patel, Ms.Meenakshi Saroha, Mr. Nishidh S. Chavda	Asst. Prof., IT Department, CCET, Wadhwan, Gujarat, India Lecturer, IT Department, KITRC, Kalol, Gujarat, India Asst. Prof., CE Department, CIT, Changa, Gujarat, India	ureshparmar13@yahoo.co.in, kgp2003@gmail.com, meenakshi.saroaha@gmail.com, nishidhchavda.ce@ecchanga.ac.in
11	<a href="#">Some Aspects Related to Flow System Test and Turbomachine Selection</a>	M. J.Zinzuvadia, Lecturer,	B V M Engg. College, Vallabh Vidyanagar	mjzbvm@gmail.com
12	<a href="#">Optimized Rumor Routing Algorithm for Wireless Sensor Networks</a>	Zalak Modi, Sunil Jardosh, Prof. Prabhat Ranjan	Gandhinagr Institute of Technology, Gandhinagar	zalak_modi2000@yahoo.com
13	<a href="#">Fabrication of Macropore Array on Silicon</a>	Mr Amit R Sharma Asst Professor	Gandhinagr Institute of Technology, Gandhinagar	amit.sharma@git.org.in
14	<a href="#">Ananlysis of Magnetic Fluid Based Squeeze Film Between Two Curved Circular Plates</a>	Mr Nikhil Abhangi, Mrs Chandani Changela	Gandhinagr Institute of Technology, Gandhinagar	nikhil.abhangi@git.org.in chandani.chanela@git.org.in
15	<a href="#">Application of Solar Powered Seed Sprayer in Agriculture- An Overview</a>	Mr. Milan J. Pandya, Mr. Shaival R. Parikh	Gandhinagr Institute of Technology, Gandhinagar	milan.pandya@git.org.in

# AEROSTATIC STABILITY ANALYSIS OF LONG SPAN SUSPENSION BRIDGES

N D Shah<sup>1</sup> D A Shah<sup>2</sup> Dr J A Desai<sup>3</sup> H S Patil<sup>4</sup>

1. Associate Professor & Head, Civil Dept., Charotar Institute of Technology, CHARUSAT, Changa.

2. Lecturer, Civil Department, Charotar Institute of Technology, CHARUSAT, Changa.

3. Director, C G Patel Institute of Technology, Bardoli – 394 350.

4. Professor, Applied Mechanics Department, SV National Institute of Technology, Surat – 395 007.

[nirajshah.cv@ecchana.ac.in](mailto:nirajshah.cv@ecchana.ac.in)

**ABSTRACT-***Deflection theory is the basic theory of cable and stiffening girder suspension bridges. Geometric nonlinearity of suspension bridges due to dead load is taken in to account in this theory. Geometrical changes are having significant effects in suspension bridges, so it cannot be neglected in preliminary analysis of suspension bridges. Series method is a new method for the deterministic aerostatic stability analysis of suspension bridges. The geometric nonlinearity in the deflection theory and the three components of displacement-dependent wind loads are taken into account in the method. A computer program for calculating change in various geometric parameters of stiffened suspension bridges is developed using HTML. Again another computer program for finding a critical wind velocity of suspension bridges was developed using MATLAB.*

## KEY WORDS

Aerostatic Stability, Suspension Bridge, Nonlinearity, Displacement Dependent Wind Load

## 1. INTRODUCTION

The basic design of a suspension bridge has been in use for centuries: thousands of years ago, people crossed waterways and chasms by swinging hand over hand on suspended cables. Later, walkways were hung from the cables to make the process easier, and the original vines and ropes began to be replaced with chains. Major bridges were still built using a truss design until 1808, when an American inventor named James Finley filed a patent on an early version of a suspension bridge. Finley's design involved stretching two strong chains over the top of several towers and anchoring them on either side of the bridge. He hung lesser chains from the two master chains and used them to suspend a rigid deck, and the modern incarnation of the suspension bridge was born.

A suspension bridge is a type of bridge which is built by suspending the roadway from cables attached to a master cable which runs above the length of the bridge. In addition to being

strong and lightweight, suspension bridges are also beautiful, and some of the most famous bridges in the world are also suspension bridges, including San Francisco's iconic Golden Gate Bridge and New York's Brooklyn Bridge. The design of a suspension bridge is simple and straightforward, and takes advantage of several techniques to distribute the weight of the bridge safely and evenly.

Suspension Bridges have received more attention due to their ability to cover the large spans. For bridging the long and unsupported spans, the Suspension Bridges present the most elegant and efficient structural solution. And hence, they are increasingly being constructed all over the world. Thus, there is a need for developing a comprehensive understanding about the detailed behavior of these bridges. Also, they are one of the costliest civil engineering projects, and hence necessitate much attention while its analysis and structural design stage. Therefore, it is imperative that a reliable analysis should be available. With the increasing central span length of suspension bridges, it becomes especially important to understand the aerostatic behavior of suspension bridges.

## 2. THEORY OF STIFFENED SUSPENSION BRIDGES & VERIFICATION

In the theory of cable and stiffening girder systems the geometrical relations between the positions and dimensions of a given element of the cable in the initial and deflected configuration is taken in to account. As shown in Fig. 1 an element of cable length is defined by  $cd$  subtends a length  $ab$  when not deflected. After deflection the point  $c$  and  $d$  move to new position  $c'$  and the length  $c'd'$  is in general not equal to  $cd$ . The vertical deflection of  $c$  is denoted by  $\eta$  and the lateral shift of the same point is  $\xi$ . The suspenders which connect  $cd$  to  $ef$  in the initial configuration, are attached to  $c'd'$  in the deflected position since  $c'$  and  $d'$  are the new positions of  $c$  and  $d$ . The deflection of the girder at  $e$  is denoted by  $v$  and is equal to the sum of  $\eta$  and changes due to the suspenders.



Structural details decide whether g shall be vertically below e and are discussed later. The slope of the undeflected cable is  $\Psi$ .

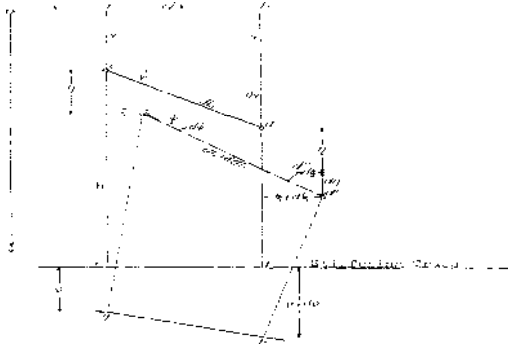

**Fig. 1: Cable Element**

Equations for calculating deflection of suspended main cable, deflection of girder, slope of undeflected cable in initial position and forces in suspenders of any finite element cable based on basic deflection theory of suspension bridges are as follows:

Lateral shift of cable element:

$$\xi = \left(1 - \frac{Hw}{EA} \sec Q\right) \left(\frac{4a_2 f}{l}\right) * \left\{ (1 - 2z) \sin 2\pi z + \frac{(1 - \cos 2\pi z)}{2} \right\} \quad (1)$$

Vertical deflection of cable element:

$$\eta = a_2 \sin 2\pi z \quad (2)$$

Initial slope of undeflected cable:

$$\Psi = \tan^{-1} \left( \frac{4f}{l} (1 - 2z) \right) \quad (3)$$

Deflection of stiffening girder:

$$v = a_2 \sin 2\pi z \quad (4)$$

Forces in the suspenders:

$$F_h = \left\{ \left[ \frac{Hw}{EA} \left[ \frac{8f}{l^2} + \frac{4\pi^2}{l^2} a_2 \sin \frac{2\pi x}{l} \right] \right] * \{h_s\} \right\} - \left\{ (h_s) * \left( \frac{w_1}{2} \right) \right\} \quad (5)$$

Horizontal component due to dead load:

$$H_w = \frac{wl^2}{8f} \quad (6)$$

Where,

E=Modulus of elasticity of cable, A=Area of cable, f=Sag of the cable, a<sub>2</sub>=Maximum deflection of structure, l= Length of

main span, h<sub>s</sub>=Hanger spacing, w= weight of main span, w<sub>1</sub>= weight of cables, suspenders etc. in main span

JavaScript is an object-oriented scripting language used to enable programmatic access to objects within both the client application and other applications. It is primarily used in the form of client-side JavaScript, implemented as an integrated component of the web browser, allowing the development of enhanced user interfaces and dynamic websites. JavaScript is a dialect of the ECMA Script standard and is characterized as a dynamic, weakly typed, prototype-based language with first-class functions. JavaScript was influenced by many languages and was designed to look like Java, but to be easier for non-programmers to work with.

A computer HTML program is developed for calculating change in various geometrical parameters due to dead load of Stiffened Suspension Bridges. Main feature of program is, it can simulate graphical presentation of deflected shape. Its accuracy has been checked by numerical example.

Properties of the main span of the Golden Gate Bridge at San Francisco are as under:

Length of Main Span= 4,200 ft., Sag of Main Span= 470 ft., Length of Side Spans= 1,125 ft., Weight of Main Span per lineal ft. Deck= 1,11,300 lbs., Weight of Cables, Suspenders etc.= 6,670 lbs., Weight of Stiffening Trusses= 3,330 lbs., Weight of Bracing= 600 lbs., Weight of Miscellaneous= 400 lbs., Total Weight =21,300lbs., Dead load for side spans per linear ft.= 21,500 lbs., Live load capacity per linear ft.= 4,000 lbs., Maximum downward deflection of Main Span= 10.8 ft., Longitudinal Tower deflections Shoreward= 22 ins., Longitudinal Tower deflections Channel ward= 18 ins., Diameter of Cables over wrapping= 36-f ins., Length of one cable= 7,650 ft., Number of wires in each cable= 27,572, Size of wire, diameter= 0.196 ins., Weight of cable, suspenders etc.= 24,500 tons., Moment of Inertia of one main stiffening girder= 43,150 in<sup>4</sup>.

## STIFFENED SUSPENSION BRIDGE

Length of main span - l (ft)

Weight of Main Span - w (ton)

Sag of the cable - f (ft)

Area of cable - A (inch<sup>2</sup>)

Diameter of cable - d (inch)

Modulus of Elasticity of cable - E (MPa)  \* 10<sup>5</sup>

Maximum deflection of a structure - a<sub>2</sub> (ft)

Hanger spacing (ft)

Weight of cable, suspenders, etc. (ton)

Steps of z

Vertical Cable Deflection			Girder Deflection				
Paper Results:[2]		Our Results		Paper Results:[2]		Our Results	
z	$\Psi$	z	$\tan(\Psi)$	$\Psi$	z	$\sin(2\pi z)$	$\eta$
0	24°7'	0	0.4476	24°7'	0.1	0.0000	0.0000
					0.2	0.5878	5.8779
0.1	19°42'	0.1	0.3581	19°4'	0.3	0.9511	9.5106
					0.4	0.9511	9.5106
0.2	15°2'	0.2	0.2686	15°2'	0.5	0.0000	0.0000
					0.6	-0.5878	-5.8779
0.3	10°9'	0.3	0.1790	10°9'	0.7	-0.9511	-9.5106
					0.8	-0.9511	-9.5106
0.4	5°7'	0.4	0.0895	5°7'	0.9	-0.5878	-5.8779
					1.0	0.0000	0.0000
0.5	0°0'	0.5	0.0000	0°0'			
0.6	5°7'	0.6	-0.0895	5°7'			
0.7	10°9'	0.7	-0.1790	10°9'			
0.8	15°2'	0.8	-0.2686	15°2'			
0.9	19°42'	0.9	-0.3581	19°4'			
1.0	24°7'	1	-0.4476	24°7'			

### 3. AEROSTATIC ANALYSIS

Bridges are frequently built on exposed sites and are subject to severe wind conditions. Aerostatic loads on bridge superstructures depend on the type of bridge, such as slab-stringer, truss, arch, cable-stayed, or suspension. Other parameters that affect aerostatic loads on bridge superstructures are the wind velocity, angle of attack, the

size and shape of the bridge, the terrain, and the gust characteristics. Aerostatic loads form a major component of lateral loads that act on all structure. In general, they are a component of the so called environmental loads to which all structures are subjected. Because of the long spans, suspension bridges have become increasingly sensitive to aerostatic instability. On the other hand, experimental observations suggest that the aerostatic instability of long-span bridges (suspension bridges and cable-stayed bridges) can occur under the action of static aerostatic loads. Therefore, the aerostatic stability analysis of long span suspension bridges under the aerostatic loads is of considerable importance.

### 4. DETERMINISTIC AEROSTATIC STABILITY ANALYSIS OF SUSPENSION BRIDGES

A series method is proposed by Jin Cheng, Jian-Jing Jiang, Ru-Cheng Xiao [10] to overcome drawbacks of existing deterministic methods for aerostatic stability analysis of suspension bridges. Series method is also proposed to investigate the aerostatic stability of suspension bridges using a hybrid method, consisting of the series method and direct Monte Carlo simulation. Presented series method contains the following characteristics:

1. The series method considers both three components of displacement-dependent wind loads and geometric nonlinearity of structure in the deflection theory of suspension bridges.
2. The following derivation of formula is based on the deflection theory of suspension bridges.

This is mainly because this theory can, to a certain extent account for the geometric nonlinearity of structure (the stiffening effect of the tension force in the cable). This conclusion has been demonstrated by the fact that the majority of the existing long span suspension bridges were correctly designed using the deflection theory before the computer era.

### 5. ASSUMPTIONS MADE IN THEORY

In the above theory, the following assumptions are made:

1. Hanger is densely distributed along the bridge length direction;
2. The stretching of hangers under wind loads is ignored;
3. Changes of critical wind velocity caused by longitudinal deformation and lateral deflection of stiffened girder are ignored;

4. Configuration of cable during on completion is quadratic parabola; stress of stiffened girder due to dead load is ignored and
5. Under the action of drag force of displacement-dependent wind loads, the load transferred to the stiffened girder from cables is assumed to be isosceles triangle distribution.

## 6. SERIES METHOD

The series method is a two-step process: the calculation of deflection response under the displacement-dependent wind loads and the calculation of the critical wind velocity. The response under the displacement-dependent wind loads is calculated from Fourier series. The critical wind velocity is calculated by means of an iterative method. It is found that a small number of iteration cycles and Fourier coefficients are sufficient enough for convergence. The series method is suitable for single-span suspension bridges.

## 7. Three components of wind loads

The three components of wind load are drag force, lift force and pitch moment. Consider a section of bridge deck in a smooth flow, as shown in Fig. 2. Assuming that under the effect of the mean wind velocity  $V$  with the angle of incidence  $\alpha_0$ , the torsional displacement of deck is  $\theta$ . Then the effective wind angle of attack is  $\alpha = \alpha_0 + \theta$ . The components of wind forces per unit span acting on the deformed deck can be written in wind axes as:

$$\text{Drag force: } F_x(\alpha) = 0.5 \rho V^2 C_x(\alpha) D \quad (7)$$

$$\text{Lift force: } F_z(\alpha) = 0.5 \rho V^2 C_z(\alpha) D \quad (8)$$

$$\text{Pitch moment: } M(\alpha) = 0.5 \rho V^2 C_m(\alpha) B^2 \quad (9)$$

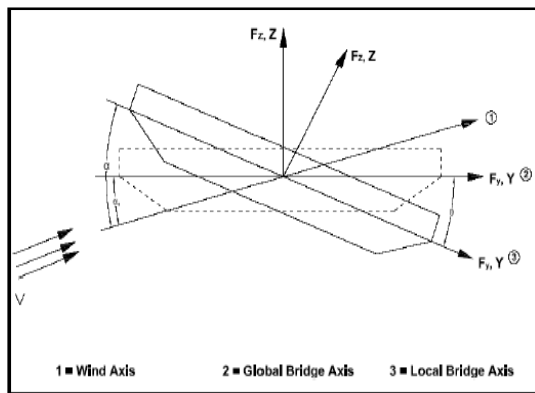

**Fig 2: THREE COMPONENTS OF WIND LOADS  
IN DIFFERENT AXES**

## 8. SOLUTION PROCEDURE

1. Calculate the initial horizontal component of cable tension owing to dead loads of cables, hangers and stiffened girder from

$$H_0 = \frac{ql^2}{8f}$$

2. Give an initial wind velocity  $V$
3. Initialize the iteration counter  $i = 1$ .
4. If  $i = 1$ , the coefficient  $b_{ri} = 0$ ,  $H_{pi} = 0$ , and  $H_i = H_0$  in Eq. (13).
5. Determine the coefficient  $a_{ri}$  by substituting  $b_{ri}$ ,  $H_{pi}$  and  $H_i$  into Eq. (13).
6. Calculate the vertical displacement of stiffened girder,  $\eta(x)$ , from (10).
7. Set  $i = i + 1$ .
8. Substitute  $\eta(x)$  into (9), and the new value of  $H_{pi}$  is determined.
9. Let  $H_i = H_0 + H_{pi}$
10. Substitute  $H_i$  into (7), and the coefficient  $b_r$  is determined.
11. Calculate the torsional displacement of stiffened girder,  $\alpha(x)$ , and the vertical displacement of stiffened girder,  $\eta(x)$ , and the lateral displacement of stiffened girder,  $u(x)$ , from (4), (10), (18) and (19), respectively.
12. Check the convergence value  $\epsilon_1$  using

$$\epsilon_1 = \left| \frac{H^i - H^{i-1}}{H^{i-1}} \right|$$

13. If  $\epsilon_1 > \epsilon_{1max}$ , go to step 5. If  $\epsilon_1 < \epsilon_{1max}$ , continue.
14. Check the convergence using
15. Check if  $H^i$  has a negative value.
16. If  $H_i$  is a positive value, update the wind velocity  $V$  using
17.  $V = V + \Delta V$
18. Where  $V$  is the incremental wind velocity, go to step 2;

	m (t/m)	E(MPa)	$\gamma$
Steel box girder	18.33	210000.0	0.3
Cable	2.397	200000.0	-
Hanger	0.172	160000.0	-

19. Otherwise, STOP (end of calculation).

The flowchart for the same is as shown in Fig. 3.

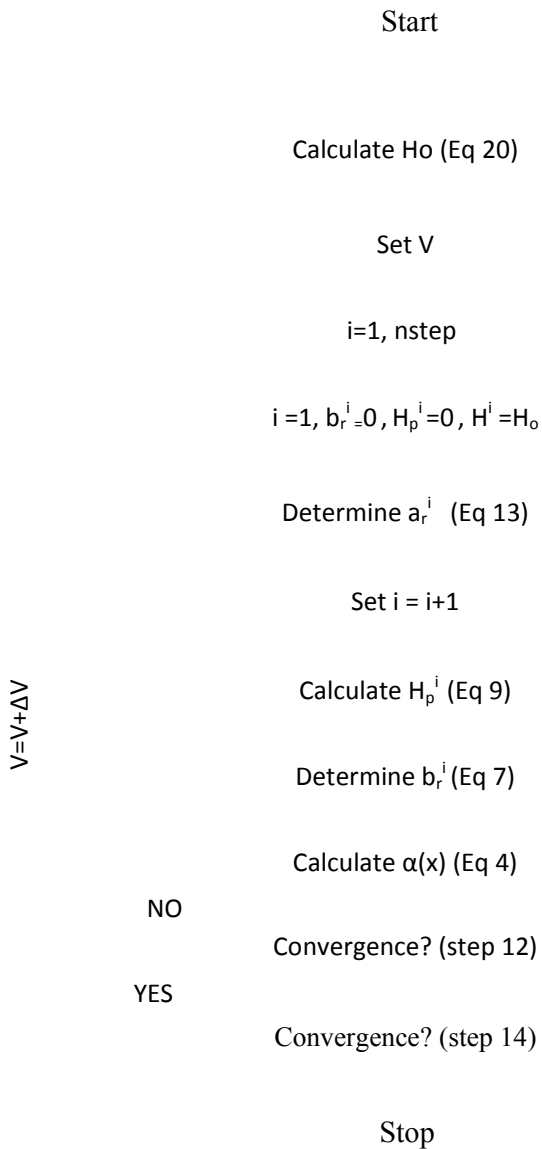

**Fig 3: FLOW CHART FOR SOLUTION PROCEDURE**

**9. VERIFICATION EXAMPLE**

The Hu Men suspension bridge in China was chosen for verification example. The general configurations of the bridge, shown in Fig. 5.03, are summarized as follows: a suspension bridge of main span 888 m; portal frame shape towers with 150 m height; closed-box deck with 3.012 m depth and 35.6 m width; width between center lines of cables is 33 m; the spacing between the two hangers is 12.0 m. section material and geometrical features of the main member are indicated in Table 1.

**Table 1: SECTION GEOMETRICAL AND MATERIAL FEATURES**

The three components of the displacement-dependent wind loads were only considered for the bridge deck while for the cables only the initial drag force was considered. The angle of incidence  $\alpha_0=0$  is taken. The coefficients ( $e_1, e_2, c_1, c_2$ ) are given by  $e_1 = 0.00877, e_2 = 0.01838, c_1 = 0.02462, c_2 = 0.0789$ . Sag of the cable is 143 m. Drag force acting on the towers was not considered.

Comparison of different methods result for critical wind velocity is shown in table 4.02. From this table it can be seen that presented series method result using matlab-7.0 is nearly equal to paper result. And quite satisfactory result in the prediction of critical wind velocity can be obtained by using MATLAB program. And <5% difference with respect to accurate critical wind velocity calculated by different methods as shown in Table 2.

Fig 4 shows horizontal tension in cable vs. wind velocity. From this fig it can be seen that horizontal tension in cable decreases with increase in wind velocity. And for a particular wind velocity it gives negative value. It indicates critical wind velocity, which may causes instability in suspension bridge.

**Table 2: RESULT COMPARISON FOR CRITICAL WIND VELOCITY**

	PAPER RESULT			MATLAB-7.0 RESULT
	NFE M	LINEAR METHOD	SERIES METHOD	SERIES METHOD
Critical Wind Velocity (m/s)	120.0	136.0	125.0	123.0

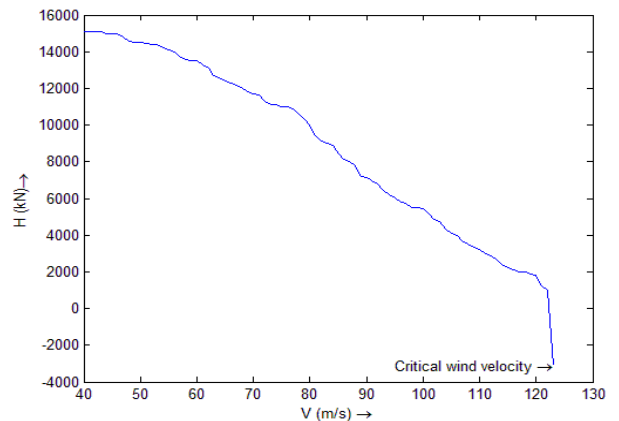

**Fig 4: HORIZONTAL TENSION VS. WIND VELOCITY**

## 10. Conclusions

From this work following conclusions can be drawn:

1. Series method gives very precise results compared to NFEM and linear method, the difference is @ <5% with respect to accurate critical wind velocity. Hence, series method is suggested for higher spans.
2. The results show that the developed program is accurate, practical, and computationally efficient.
3. By using series method, the problem of aerostatic analysis is greatly simplified, thus saving of computation time significantly.
4. Vertical deflection and lateral shift of main cable element is having significant effect in deflected configuration of stiffened suspension bridges.
5. To determine longitudinal movement of the girder, due to the inclination of the suspenders it is necessary to know the forces in the suspenders.
6. Salient feature of HTML program is, it can simulate deflected shape of a cable element at various distances from tower.

## 11. References

1. B. Semper "A Mathematical Model Suspension Bridge Vibration", *Math1. Computer Modeling*, Vol. 18, No. 11, pp. 17-28, 1993.
2. Dino A. Morelli "Some Contribution To The Theory Of The Stiffened Suspension Bridges"
3. E.S. Kreis, J.C. Andr "A Numerical Inquiry into The Flutter Phenomenon in Long-span Bridges", *Latin American Journal of Solids and Structures*, 2 (2005) 321–337
4. Haifan Xiang, Yaojun Ge "Refinements on Aerodynamic Stability analysis of Super Long-span Bridges" *Journal of Wind Engineering and Aerodynamics*, Elsevier, 90 (2002) 1493–1515,
5. H. Erdogan, E. Gulal "The Application of Time series analysis to Describe the Tynamic Movements of Suspension Bridges", Elsevier , *Nonlinear Analysis: Real World Applications* 10 (2009) 910–927.
6. Henrik Ditlev Nissen, Paul Haase Sorensen.and Ole Jannerup "Active Aerodynamic Stabilisation of Long Suspension Bridges", Elsevier , *Journal of Wind Engineering and Industrial Aerodynamics* 92 (2004) 829–847.
7. Jin Cheng, Jian-Jing Jiang.and Ru-Cheng Xiao, Hai-Fan Xiang "Nonlinear Aerostatic Stability analysis of Jiang Yin Suspension Bridge", Elsevier , *Engineering Structures* 24 (2002) 773–781.
8. Jin Cheng, Ru-cheng Xiao "Probabilistic Free Vibration and Flutter analyses of Suspension Bridges", Elsevier, *Engineering Structures* 27 (2005) 1509–1518.

# Flooding in Computer Network With Passive Clustering

Darshana Mistry

Computer Engineering Dept., Gandhinagar Institue Of Technology,  
Ahmedabad, India  
Darshana.mistry@git.org.in

**Abstract**— An ad hoc network is a fast deployable self configuring wireless network characterized by node mobility, dynamic topology structure, unreliable media and limited power supply. Nodes in an ad hoc network must cooperate and carry out a distributed routing protocol in order to make multi-hop communications possible. On Demand Routing is one of the most popular routing styles in ad hoc networks. In On Demand Routing, "flooding" is used to find a feasible route from source to destination. The function of flooding is to deliver a packet from one source to every other node in the system. Conventional flooding can be very costly in On Demand networks in terms of network throughput efficiency as well as node energy consumption. The main reason is that the same packet is rebroadcast unnecessarily several times (redundant rebroadcast). Indeed, the penalty of redundant rebroadcast increases when the size of network grows and the density of network increases. In this paper we introduce a novel clustering scheme, call Passive Clustering that can reduce the redundant rebroadcast effect in flooding.

**Keywords**-Flooding, Passive Computing

## I. FLOODING IN COMPUTER NETWORKS

Flooding is a packet dissemination procedure by which every incoming packet at a node is sent out on every outgoing link except the one it arrived on. In a wireless environment, the physical exclusion of the arriving link is impossible. Since the media is broadcast, a single relay of a flooding packet fulfils the task if the broadcasting is successful, i.e., all neighbors receive the packet. Unfortunately, some of the neighbors may not receive the packet due to many reasons including noise, receivers' status, mobility, collision etc. Since every neighbor that has received the packet will rebroadcast it, flooding can generate an infinite number of duplicate packets if there is no control mechanism. One of the mechanisms for prohibiting infinite duplication is tracking flooding packets. Duplicates are detected (from a unique source identifier and a sequence number, for example) by each receiving node and are immediately discarded in order to avoid endless looping. Another control mechanism is Time-to-Live (TTL). A flooding packet carries

a TTL field which represents the maximum hop that the packet can traverse. Upon reception of a flooding packet, the receiving node checks the TTL field and determines whether the packet will be rebroadcasted (after decreasing TTL) or dropped. Path logging in a flooding packet can also be a controlling mechanism. By carrying a list of nodes that a flooding packet has visited, a node can easily avoid looping by examining its ID in the list. If there is a match, the node drops the "returning" packet. In spite of the control mechanisms listed above, flooding generates replicated packet arrivals to each node; namely, one replica for each neighbor. Thus, flooding overhead corresponding to replicated, redundant packets increases with connectivity. Flood search is the capstone of all on-demand rough and multicast protocols. These protocols need to find a path on demand. Since one generally assumes that there is no underlying routing or relative geographical positioning infrastructure that can guide the packet to destination, a path search query must be flooded to the entire network, or at least through a certain section (scope) of it. Once the path search query packet reaches a destination by flooding, the destination can report a path to the source as a reverse path through which the search packet came. Or the destination can report the path to the source with another flooding in case there are asymmetric links. AODV (Ad hoc On-demand Distance Vector routing [1]), for example, uses seeded flooding to find a route. By tagging "Time To Live (TTL)" on each Route-Request flooding packet, a source gradually enlarges flood search diameters. On the other hand, DSR depends on complete flooding to the entire network if a source cannot find a path to destination in a single hop. If the communication patterns are "local", scoped flooding is effective. On the other hand, if destinations typically many hops away, it would be wasteful to run the incremental scoped flooding.

## II. EFFICIENT FLOODING

Generally speaking, flooding in ad hoc networks is used to find a feasible route to a destination or to advertise routing information. If the network is dense, it is not necessary for every node to relay the flood search packet. In fact, it may suffice to use only a subset of nodes as relays. There are many ways to reduce the number of forwarding participants. All of the approaches concern selecting the dominant set, i.e.,

a minimal subset of forwarding nodes which is sufficient to deliver the flooding packet to every other node in the system. There are two basic approaches for selecting the dominant set: without and with a clustering structure. The first approach (no clustering) includes the building of a source tree with the maximal number of leaf nodes and the building of a well covered mesh [6,7]. By excluding leaf nodes from forwarding participation, the method can improve flooding efficiency. To build such source tree, two hop connectivity information is necessary. To collect the required information, at least two complete floorings from a source are necessary. The first flooding (which can be replaced with well-coordinated hello messages) is to learn the one-hop neighbors. The second flooding is to report the direct (one-hop) neighbor lists. By collecting the complete neighbor lists of all of its neighbors, a node can construct the two-hop connectivity, i.e., the list of nodes that are two hops away. From this list, each node selects the minimum set of one-hop neighbors which cover all the downstream two-hop neighbors. This problem can be reduced to the well-known "set-cover" problem (NP-complete). Starting from a source and applying this procedure recursively one generates the non-leaf nodes of a minimal flooding tree. Span and GAF build their dominant set as a well-covered mesh. Span selects nodes that are potentially on critical paths as coordinators, i.e. members of a dominant set. GAF partitions the region with a grid such that any nodes in neighboring cells can communicate each other; one node per cell is selected to form the dominant set. The complexity of the selection algorithm in this category is dependent on the number of neighbors (except for GAF which requires GPS information instead). In other words, complete neighbor list knowledge is always the assumption. Note that the neighbor-learning procedure is not trivial in ad hoc networks and it involves substantial overhead with high node density and mobility. The second approach is based on a two-hop clustering structure. To illustrate this concept, let us consider the n node example in Figure 1. Let r be a transmission range, and the size of the roaming space be  $((k/\sqrt{2})r) * ((k/\sqrt{2})r)$  where k is an even number (Figure 1 depicts the case of k = 6). There are n nodes in the square, but in the figure we only show the nodes at coordinates  $((a/\sqrt{2})r, ((a/\sqrt{2})r))$  where either a or b is an integer smaller than k. This "selection" of nodes is known as "two hop clustering", ie, any two nodes in a cluster are separated by at most two hops. The nodes at the center of the circles are "cluster heads" and the light-shaded nodes in between are "gateways." Clearly, such nodes represent a connected set. They are in fact the dominant set required to forward the flood packets. Without the cluster overlay shown in Figure 1, each flood packet is relayed exactly n-1 times, as each node must rebroadcast the packet once. On the other hand,

$$(k-1)*k/2+k/2(k/2-1)=(k*(3*k-4))/4$$

broadcasts suffice if only cluster heads and gateways forward the packet. Note that in the cluster restricted forwarding, ALL nodes still receive the flood packet. The flooding reduction is thus  $((k*(3*k-4))/4)/(n-1)$  In case of n = 100

and k=6, the number of broadcasts required in the cluster is 21 instead of 99. In other words, 78.8% of transmissions can be saved. This is not even a very dense network (each node has about 12 neighbors). As we increase the number of nodes in the system (and therefore the density), the clustering structure and thus the broadcast remains the same. As a result, the saving increases with the node density,

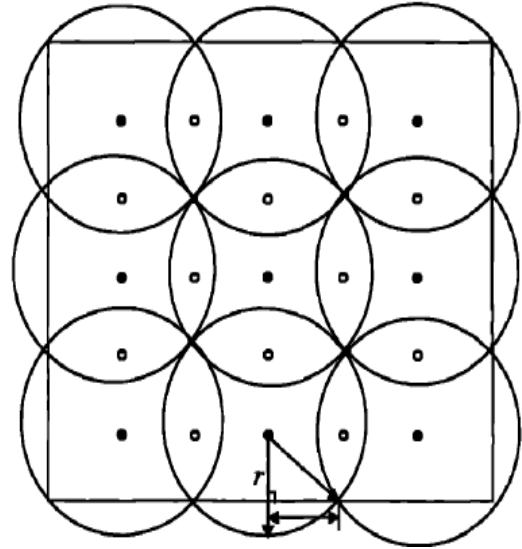

Figure 1. Selective Gateway Flooding Scenario

### III. CLUSTERING IN AD HOC NETWORKS

In the previous section we showed that clustering is one of the key approaches to flood overhead reduction. In this section, we elaborate on this important concept. Clustering in wireless ad hoc networks has been investigated in the past in order to enhance network manageability, channel efficiency, and energy economy. Moreover, clustering is indispensable for hierarchical routing or multicasting[2]. However, the clustering schemes proposed so far in the literature are "active". They require a constant refresh rate of cluster-dependent information, and therefore introduce significant background control overhead even if there is no data to send in the network. In some applications, for example, covert military operations and sensor networks, this periodic control traffic is highly undesirable. The penalty introduced by the control traffic (eg, exposure to enemy interception, power consumption, etc) may offset the benefits offered by clustering. Clustering in ad hoc networks can be informally defined as *grouping of nodes into a manageable set*. Many prior research efforts carried out clustering in different ways. Such efforts started with the DARPA packet-radio network. As a result, the network was dynamically organized into clusters similar to the cluster structure shown in fig. 1.

Several clustering mechanisms have been proposed in the literature. The schemes reported in all lead to similar structures (overlapping two-hop clusters with cluster heads). The schemes in partition the network into disjoint sets of clusters. All of these clustering mechanisms assume prior knowledge of the full neighbor list, or they periodically monitor neighbor information by exchanging explicit control

packets. This topology learning overhead is significant if the number of neighbors is large and the topology is dynamic. None of these schemes will work properly with only partial neighbor information. An important subclass implements two-hop clustering. Two-hop clustering requires that every node in a cluster be reached from another node in the same cluster with at most two hops. Two-hop cluster is a natural clustering structure in ad hoc networks. It only requires direct neighbor information and is easy to construct. The cluster structure in Figure 1 is an example of a two-hop cluster structure. Two-hop clustering has the following properties:

- There is a cluster head at the center of a cluster, and the cluster head can communicate with any node in the cluster with a single hop.
- No cluster heads are directly linked.
- Any two nodes in a cluster are at most two hops away. Two-hop clustering ends up with a structure similar to the cellular system. There are cluster heads at the center of each cluster (a useful by-product). Nodes belonging to more than one cluster are gateways. The rest of the nodes are ordinary nodes.

#### *A.Limitation of Existing (Active) Clustering Scheme*

Most clustering algorithms in the past have been studied via simulation and have used the complete neighborhood information. Unlike the simulation environment, accurate global information regarding node locations and adjacency relations is hard to collect in an actual wireless ad hoc network implementation, especially when the node density is high. The major difficulties stem from unreliable and limited link capacity, and from node mobility. Node locations and neighborhood information are key for clustering; unfortunately, they do vary in time. Without the help of a special node – say "oracle" which can listen or talk to all the nodes at the same time - adjacency (neighborhood) information can only be collected by exchanging beacons or hello messages. In this neighbor learning process, no mobility is generally assumed. To ensure the correct collection of neighborhood information, existing clustering solutions rely on periodic broadcast of the neighbor list. In the period of neighbor learning and initial clustering, it is essential that there is no mobility for proper convergence. The quasi-stationary assumption must hold during the adjacency information collecting period, initial clustering, and the re-clustering or clustering maintenance period. If there is motion, we may have to deal with stale neighborhood information during the neighbor learning period. Moreover, mobility causes adjacency relations to change, which in turn may trigger re-clustering throughout the network. Other drawbacks including isolation (structural disconnection), etc., are listed and explained in.

## IV. PASSIVE CLUSTERING

In this section, we introduce a new cluster formation protocol that is free from the periodic overhead and other limitations discussed in the previous section. This novel approach not only overcomes many limitations of existing clustering mechanisms, but also improves performance and yields new features. Here, we present the concept of passive clustering and illustrate its operation by example. The proof of its correct operation and the detailed description can be found in.

### *A.Protocol Overview*

Passive Clustering is a cluster formation protocol that does not use dedicated protocol-specific control packets or signals. Conventional clustering algorithms[2], as earlier discussed, require all of the participating network nodes to advertise cluster dependent information repeatedly. Moreover, most of the existing clustering schemes require the execution of a separate clustering phase prior to any network layer activity (e.g., routing). With passive clustering, we avoid all the above limitations. By monitoring user data packets that piggyback some predefined cluster information, we can build impromptu "soft state" clusters for mobile wireless networks. Thus, the cluster infrastructure can be constructed as a by-product of user traffic, without any dependency on the routing protocol, for example. In passive clustering, each node collects neighbor information from the MAC sender address carried by the incoming packets, and can construct clusters even without collecting the complete neighbor list. This is an innovative approach to clustering which virtually eliminates major cluster overheads - the time latency for initial clustering construction as well as the communication overhead for neighbor information exchanges. Instead of using protocol specific signals or packets, cluster status information (2 bits for four states: Initial, Cluster head, Gateway, and Ordinary-node states) of a sender is stamped in a reserved field in the packet header. Sender ID (another key piece of information for clustering) is carried by all the existing MAC protocols and can be retrieved from the MAC header. Since in flooding the MAC packets are transmitted in broadcast (instead of unicast mode, every node receives and reads the packets (in a promiscuous way), and thus participates in passive clustering. Note: you cannot perform flooding at the MAC layer because you need to detect duplicates (reading, for example, flood originator ID number which is stored in the packet, not MAC, header). Since passive clustering relies on flooding packets, it may as well be done at the packet layer. Surprisingly, simulation results show that passive clustering can form better clusters than conventional clustering schemes based on eight (i.e., ID, degree, etc.) information. This is because passive clustering (as used in the support of ad hoc muting schemes) uses network traffic that emanates from sources (i.e., the source in search of a path). If a cluster structure is constructed by a flooding from a single source, the resulting structure is completely immune from logical isolation and lack of connectivity. Clustering stability and fast convergence time are other important properties required of clustering



algorithms. To improve clustering stability and speed up convergence, and most importantly, to avoid the "stationary" requirement during the neighbor-learning and clustering phase, we developed a new cluster head election rule which does not require any weight information. We call this rule "first declaration wins." With the first declaration wins rule, a node which first claims to be the cluster head remains the cluster head and "rules" the rest of nodes in its clustered area (radio coverage). There is no waiting period (to make sure all the neighbors have been checked) unlike in all the weight-driven clustering mechanisms.

### B. Operational Description

When a node is ready to become a cluster head and has packets to send, it declares that it is a cluster head by stamping its clustering state claim in the packets. Since passive clustering does not support explicit control packets or signals of its own, a cluster head-ready node must postpone its claim until it has outgoing "application" packet level traffic, for example, flood search packet traffic. After a successful transmission from an aspiring cluster head, every node within radio coverage learns the presence of the cluster head by monitoring the "cluster" state of the received packets. At this point, the neighbors of the cluster head record the cluster head information (cluster head ID and the most recent transaction time-timestamp) and change their clustering states as discussed below. The readiness of being a cluster head is determined by network activities as well as by the node's clustering state. After a period of inactivity (i.e., no incoming or outgoing traffic for longer than the cluster timeout period), all the nodes revert to the INITIAL state. Only nodes in INITIAL state can be cluster head candidates - in other words, two hop is the minimum distance between any two cluster heads since all neighbors of a declared cluster head exit the INITIAL state. After a cluster head successfully asserts its state, it functions as a cluster head. Cluster heads collect neighbor information by monitoring the network traffic. They are responsible for relaying intra cluster packets. A node that hears more than one cluster head becomes a GATEWAY. It reverts to ORDINARY node if it does not hear from more than one cluster head for a given period. In the next section we will describe a slightly modified procedure (selective gateway) in which a part of gateways in this definition also reverts to ordinary node upon hearing a certain number of other gateways. A node that is neither a cluster head nor a gateway is an ordinary node. The ordinary node does not forward flooding packets. It is precisely this forward-suppression mechanism that reduces flood overhead. Gateway nodes and cluster heads, on the other hand, will keep forwarding the flood packets. Because of the passive nature of the collection mechanism, neighbor information is kept in soft state and is possibly incomplete. Note here again that complete neighbor information is no longer necessary to form the structure. By using timestamps for neighbor information, we preserve the freshness of the information. Ordinary nodes and gateways keep a list of their cluster head(s) in soft states. The time, out period has to be carefully chosen based on node mobility and communication pattern.

Non-cluster head nodes can collect their own cluster head(s) information in a passive way. If a received packet is from a cluster head (after checking the status information in the packet), non-cluster head nodes compare the sender ID of the packet with their own cluster head list and add or refresh accordingly.

## V. SELECTIVE GATEWAY PASSIVE CLUSTERING

In typical examples implementing the above basic scheme, one quickly discovers that the number of gateways is quite significant and is typically larger than that of ordinary nodes. Clearly, there is quite a bit of redundancy here, and not all of the gateways have to relay the flooding packets. It is mandatory to reduce the number of gateways in order to achieve efficient flood search packet suppression. Careful gateway selection is the natural solution to improving flooding efficiency. To select the strictly minimal set of gateways, we would need to collect the cluster head list for each gateway, and then choose one gateway for each pair of cluster heads. This is another set-cover problem and introduces extra communication and computation overhead since the procedure requires cluster head list exchanges between gateways. In order to avoid the communication and computation complexity, we introduce a heuristic solution to this problem in the following section.

### A. Gateway Selective Heuristic

Instead of selecting a single gateway between adjacent cluster heads (two-hops away), we developed a heuristic algorithm that enables a limited number of gateways, and at the same time, preserves adequate connectivity within the resulting cluster structure. The selection algorithm provides many advantages including on-the-fly flooding improvement, redundant connectivity, and higher overall flooding efficiency. The heuristic also allows "distributed gateway" implementations. Every non-cluster head node monitors and keeps track of the number of cluster heads (NC) and the number of gateways (NG) within range. Whenever a non-cluster head node hears a packet from a cluster head or a gateway, the node becomes a gateway if  $a \cdot NC + fl > NG$ , where  $a$  is a coefficient properly chosen based on the desired degree of gateway redundancy ( $a \geq 0$ ) and  $fl$  is a gateway redundancy factor ( $fl \geq 0$ ). Otherwise, the non-cluster head node becomes an ordinary node. The larger the number of cluster heads that a node can hear, the higher the chance to become a gateway. By manipulating  $a$ ,  $fl$ , we can control the number of gateways in the system. The larger the number of gateways, the lower the gain in forwarding overhead reduction. On the other hand, if there are too few gateways, connectivity may be impaired leading to a poor network performance. In this paper,  $a$  and  $fl$  are global system parameters and are both set to 1. The values of  $a$  and  $fl$  should be chosen based on considerations including channel quality, noise level, as well as traffic pattern. For that reason,  $a$  and  $fl$  can be local parameters, i.e., they can be locally adjusted to provide better adaptability and flexibility. In dense networks where packet collisions abound, higher values of those

parameters lead to more gateways and better network performance by distributing network traffic over more gateways. Conversely, in low density we suggest to keep the parameters low to discourage multiple gateway creation. By introducing these heuristic, passive clustering strikes a good balance between cluster heads and gateways and retains only a handful of forwarding nodes for flood search no matter how high the node density is. The gateway selection procedure is fully distributed, and requests only local information. No cluster head fist exchange is required.

### *B. Flooding Improvement on Fly*

Let us consider the example of single-source flooding from a cold start. Every node is in the Initial state, and a source broadcasts a Route Request packet. The immediate neighbors of the source receive the packet, and change their state to Cluster head-Ready. When one of the neighbors is ready to forward the packet, it changes its state to Cluster head, and broadcasts the Route Request packet with the Cluster head state assertion. This time, all the nodes including the source that receive the relayed Route Request packet from that newly proclaimed cluster head are eligible to become gateways since they have heard from one cluster head, and from no gateways (for simplicity, in this case we assume  $a = 1$  and  $p = 0$ .) Now, one of the gateways except the source may relay the flood search packet. This relay does not switch any gateways back to ordinary nodes because they still have the number of cluster heads ( $= 1$ ) which is equal to or smaller than the number of gateways (0 or 1). Let us say that a second gateway within range of the first declared gateway relays the flooding packet. Thereafter, none of

nodes in the intersection area of those two gateways can become a gateway - they turn into ordinary nodes after they receive the second flooding packet - their head count for cluster head equals 1 but they have already 2 gateways. One may notice that there is a chance of critical path loss with these heuristics. However, extensive simulation experiments have shown that the risk of flood delivery failure to certain areas of the network is negligible, even with moderate node density, if the coefficient  $a$  and the redundancy factor  $p$  are properly chosen. With additional assistance from the routing protocol, we can completely eliminate such "block out" areas.

### *C. Properties of Passive Cluster Solution*

It is appropriate at this point to compare and contrast passive clustering with traditional, lowest ID active clustering. We have already discussed the impact of the background updating procedure and the neighbor list broadcast requirements on the control traffic overhead caused by active clustering. Here we focus on the structure of the solutions. Typically, one finds that the two solutions are comparable (in terms of number and layout of clusters). Major differences are: (a) the fact that active clustering is carried out independently, in the background and in parallel across all nodes in the network, while passive clustering is "on-demand" and is initiated by a single "source", namely the first source that needs to send data. Thus, active clustering tends to lead to disconnected islands (which require the

"distributed gateway" feature- ie gateway to gateway links to reestablish connectivity). Passive clustering does not suffer from this problem (albeit it can also be extended to support distributed gateways) (b) the fact that passive clustering features the "selective gateway" provision. Popular active clustering schemes do not include such feature (c) the lowest ID feature tends to make the active clustering more sensitive to mobility - the cluster head can be more easily challenged by newcomers with lower ID Another important issue is the suitability of Passive Clustering for Low Energy operations, as in battlefield scenarios or sensor network applications. Repeated selection of the same subset of clusters and gateways can be detrimental to low power operation in that it creates uneven energy consumption. In this respect, passive clustering is beneficial. In fact it favors even distribution since at each new cluster formation round (caused by the arrival of a new user data session, say), new clusters and gateways are selected as the source changes and/or, even in the case of same source, the random timers cause different cluster-heads and gateways to assert their role first. In the case of "permanent" traffic pattern where the cluster structure tends to persist, a possible remedy is to associate the cluster-head and gateway status with a minimum energy level requirement. When energy drops below this threshold, the role is given up triggering a new election.

## VI. CONCLUSION

A passive new clustering algorithm for efficient flooding in ad hoc networks. For efficient flooding, we propose to superimpose an on demand cluster structure which can be quickly deployed in the "unstructured" ad hoc network, and let only non-ordinary nodes (cluster heads, gateways, "initial state" nodes) participate in the flooding process. Due to its passive nature, passive clustering does not introduce any control packets dedicated to the protocol. In other words, it is "control overhead free". Thus, it can reduce the cost of flood search significantly without producing any line overhead. Even better, there is no preparation time or overhead for selecting dominant sets. As the results, the number of flooding relays can be significantly reduced even during the first flooding. This is the unique feature and strongest advantage of the proposed mechanism. It is especially useful for ad hoc networks with high mobility. The gateway selection scheme is density-adaptive. Its efficiency increases linearly with the number of neighbors, ie, with node density. Beside assisting with flood reduction, the clustering structure offers several other side benefits. In particular, it can be beneficial to routing scalability, reliability and QoS support. Passive clustering is a self-sufficient clustering scheme. The protocol collects all the

necessary information itself and does not require costly information like global topology knowledge from the lower layer. The resulting cluster structure is superior to any existing clustering algorithm in terms of stability, mobility robustness and connectivity. Passive clustering can build the cluster structure with partial neighbor information which, in most cases, is the only possible information available in an ad hoc network.

## REFERENCES

- [1] Das S.R, Perkins C.E. and Royar E.M. "Performance comparance of Two On-demand Routing Protocols for Ad hoc Networks, In processing of IEE INFOCOM 2000, Tel Aviv, Isreal, March 200.
- [2] T. J. Kwon, M.Geria, "Efficient flooding with passive clustering(PC) in Ad hoc networks",ACM SIGCOMM,44-56.
- [3] K. Obraczka, K.Vishvanath, "Flooding for Reliable Multicast in Multi-Hop Ad hoc networks", Wireless networks,627-634, Kluwer Academic Publishers, 2001
- [4] J. Li, P.Mohapatra, "PANDA: A novel mechanisam for flooding based route discovery in ad hoc networks",Wireless networks (2006) 771-787.
- [5] V.Shurbanov, J.Redi, "Energy efficient flooding in Mobile Ad hoc networks"
- [6] Chen, B., Jamieson, K., Balakrishnan, H. and Morris, R., Span: An energy-efficient coordination algorithm for topology maintenance in Ad Hoc wireless *networks*, In Proceedings of ACM/IEEE MOBICOM 2001, Rome, Italy, 2001.
- [7] Xu, Y., Heidernann, J. and Estrin, D., *Geographyinformaed* Energy Conservation for Ad Hoc Routing..In Proceedings of ACM/rEi~ MOBICOM2001,

# ANN BASED INTELLIGENT CONTROLLERS FOR AN INDIRECT VECTOR CONTROLLED THREE-PHASE INDUCTION MOTOR

Ami Patel<sup>1</sup> \* Tejendra Pate<sup>2</sup>

1. Assistant Professor, MGITER, Navsari

2. P.G. Student SVNIT, Surat

43/B Alka Co. op. Hsg. Society, Chhapra road, Navsari,

Pin code: 396445, (M): 1) 9724326517

[ami\\_engg86@yahoo.com](mailto:ami_engg86@yahoo.com)

[ami.mgiter@gmail.com](mailto:ami.mgiter@gmail.com)

**Abstract:** Artificial Intelligent methods such as Fuzzy Logic control and Neural Network control have found high applications in most of the nonlinear systems like the electric motor drives. These Intelligent controllers can be used for any system without requirement of the system mathematical model unlike that of the conventional electrical drive control, which requires the mathematical model. Due to the usage of the FLC and Neural Network control concept, the efficiency, reliability & performance of the AC drives increases. This paper presents a Fuzzy logic and Neural network based speed controller and its design for vector controlled induction motor drive. These controllers have been implemented on 3 phase, 415 V, 5 HP squirrel cage induction motor. Test response for the developed schemes are given and discussed in detail.

**Key words:** Induction motor, Vector control, Fuzzy logic, Neural Network

## 1. Introduction:

Induction motors are widely used in industries due to its robust construction and low maintenance. Separately excited dc drives are simpler in control because independent control of flux and torque can be brought about. In contrast, induction motors involve a coordinated control of stator current magnitude and the phase, making it a complex control. The stator flux linkages can be resolved along any frame of reference. This requires the position of the flux linkages at every instant. Then the control of the ac machine is very similar to that of separately excited dc motor. Since this control involves field coordinates it is also called field oriented control. The requirement of the phase angle of the flux linkages in the control process gives the name vector control. [1]

Along with industrial progress high performance drives are essential. Recent advances in semiconductors, converters and new control techniques have great role in this progress. Usually classical control requires accurate mathematical model of the system and also its performance decreases for nonlinear system such as drives. Recently by adapting non linear speed control techniques the dynamic performance of electric drives can be improved.

This paper proposes implementation of fuzzy logic and Neural Network control scheme applied to model of Induction motor. Both the controllers are developed on MATLAB environment. The performance of Fuzzy logic controller and Neural Network controller is compared with that of classical controller in terms of rise time and steady state error. The developed control scheme was verified by simulation and the results obtained demonstrate the effectiveness of Intelligent controllers.

## 2. Indirect Vector control:

Indirect vector control method is very popular in industrial applications. The block diagram of VCIMD is shown in fig.1. The motor current is decomposed in two components  $i_{ds}$  and  $i_{qs}$ , direct and indirect axis current with respect to synchronously rotating reference frame. These current are responsible for producing flux and torque respectively. Here unit vector signals are generated in feed forward manner. This method uses indirect procedure to ensure presence of rotor flux in the direct axis. With the help of an intelligent controller, the speed error is converted into a torque controlling current component  $i_{qs}$ , of the stator current. This current component is used to regulate the torque along with the slip speed. [1]

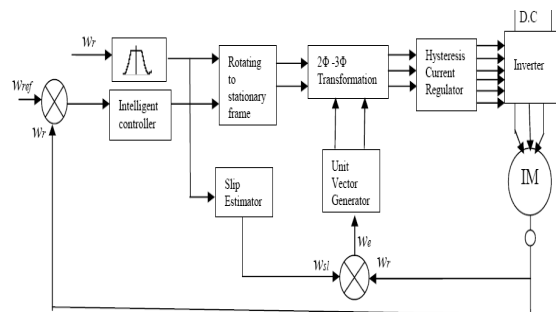

Fig.1 Block diagram of Indirect Vector control method

The following equations are necessary to implement vector control scheme.

$$\theta_e = \int (w_r + w_{sl}) \quad \text{----- (1)}$$

The rotor circuit equation can be written as,

$$\frac{d\Psi_{ar}}{dt} + R_r i_{ar} - (w_e - w_r) \Psi_{qr} = 0 \quad \text{----- (2)}$$

$$\frac{d\Psi_{qr}}{dt} + R_r i_{qr} + (w_e - w_r) \Psi_{qr} = 0 \quad \text{----- (3)}$$

For decoupling control,

$$\Psi_{qr} = 0$$

$$\frac{L_r}{R_r} \left( \frac{d\Psi_r}{dt} \right) + \Psi_r = L_m i_{ds} \quad \text{----- (4)}$$

The slip frequency can be calculated as,

$$w_{sl} = \frac{L_m R_r}{\Psi_r L_r} I_{qs} \quad \text{----- (5)}$$

$$\Psi_r = L_m i_{ds}$$

Thus, rotor flux is directly proportional to current  $i_{ds}$  in steady state. The motor developed torque is directly related to  $i_{qs}$  as follows:

$$T_e = \left( \frac{3}{2} \right) \left( \frac{P}{2} \right) \left( \frac{L_m}{L_r} \right) \Psi_r i_{qs} \quad \text{----- (6)}$$

$$i_{qs} = \left( \frac{4}{3P} \right) \left( \frac{L_r}{L_m} \right) \left( \frac{T_e}{\Psi_r} \right) \quad \text{----- (7)}$$

This current component is used to regulate the torque. [2]

### 3. Fuzzy Logic speed controller Principle and Design:

Basic structure of the fuzzy logic controller to control the speed of the induction motor consists of 4 important stages: Fuzzification, Knowledge Base, Decision-making unit and the Defuzzification. [3]

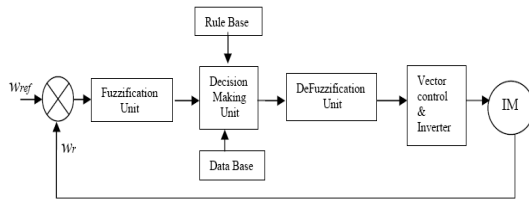

Fig.2 Fuzzy logic controller used for vector control method

The design of fuzzy logic controller start with defining input/output variables of controller. In this case first input variable is speed error  $e(k)$  and second is the change in speed error  $_{e}(k)$ . The output variable of the FLC is the change in the torque.

#### 3.1 Fuzzification:

In this stage the crisp variables  $e(k)$  and  $_{e}(k)$  are converted into fuzzy variables which can be identified by membership function. The fuzzification maps the error and change in error to linguistic labels of fuzzy sets. The proposed controller uses following linguistic labels:

NB (Negative Big), NM (Negative medium), NS (Negative small), NVS (Negative very small), Z (Zero), PVS (Positive Very Small), PM (Positive Medium), PB (Positive Big).

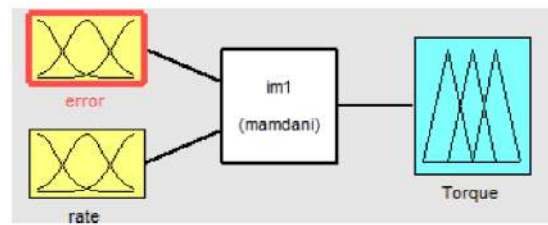

Fig.3 FIS fuzzy editor

#### 3.2 Knowledge Base and Decision making Unit:

Knowledge base involves defining the rules represented as IF-THEN rules statements which govern relationship between inputs and output variables in terms of membership functions. In this stage the input variables are processed by inference engine that executes 7x7 rules represented in rule base using fuzzy operator (AND,OR). The mapping of the fuzzy inputs into the required output is derived with the help of a rule base as given in following Table.

Table: 1 Rules of Fuzzy Logic Controller

e \ de	NB	NM	NS	Z	PS	PM	PB
NB	NB	NB	NB	NM	NS	NVS	Z
NM	NB	NB	NM	NS	NVS	Z	PVS
NS	NB	NM	NS	NVS	Z	PVS	PS
Z	NM	NS	NVS	Z	PVS	PS	PM
PS	NS	NVS	Z	PVS	PS	PM	PB
PM	NVS	Z	PVS	PS	PM	PB	PB
PB	Z	PVS	PS	PM	PB	PB	PB

Considering the first rule, it can be interpreted as: IF speed error is NB and rate of change of speed error NB, THEN the output will be NB.

#### 3.3 Defuzzification:

The output of the decision-making unit is given as input to the de-fuzzification unit and the linguistic format of the signal is converted back into the numeric form of data. In this paper, the center of gravity (COA) or centroids method is used to calculate the final fuzzy value  $T(k)$ . This  $e_{de} \text{Torque}$  value is used to calculate  $i_{qs}$ , which in turn used to command the induction motor via 2Φ-3Φ block.

#### 4. Neural Network Controller:

The ANN is an Artificial Intelligent technique which is machine like human brain with properties such as learning capability and generalization. It is a system of interconnecting neurons in a network which work together to form the output function. Neuron is a fundamental processing component of a neural network.[5] The performance of ANN relies on member neurons of network collectively. So that it can still perform its overall function even if some of the neurons are not functioning. Thus, they are very robust to error failure. It required a lot of training to understand the model of the plant. To approximate complicated nonlinear functions is the basic property of ANN. [6]

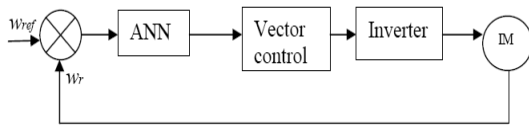

Fig.4 Neural network controller used for vector control

Here, neural network is used to produce torque producing component of current  $i_{qs}$ .

The back propagation training algorithm is used for this network. The following matlab simulation program is developed for this purpose, which train the network using the back propagation training method.[8]

Code:

```
net=newff(minmax(ip11),[2,1],{'tansig','purelin'},'traingd');
net = init(net)
net.trainParam.show =50;
net.trainParam.lr = 0.1;
net.trainParam.epochs =5000;
net.trainParam.goal = 0.001;
[net,tr]=train(net,ip11,op11);
a = sim(net,ip11);
```

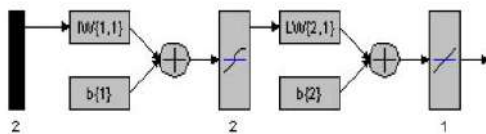

Fig.5 Neural Network Model

### 5. Results and discussion:

Here fuzzy Logic controller and Neural Network controllers are developed. Both of these are constructed into MATLAB/SIMULINK environment. Simulation tests were carried out on the PI controller, FL controller and Neural Network controller. Results are compared response.

Figure 6 show the comparison of speed response of PI, FLC and Neural Network controllers at no load. Rise time of fuzzy logic controller is found better compare to conventional PI controller. Rise time of neural network controller is less than that of fuzzy and PI controller. Both fuzzy and neural controller does not find any overshoot. Steady state error is within limit for both fuzzy and neural network controller. Figure 7 (a), Fuzzy logic controller and Neural network controller respectively.

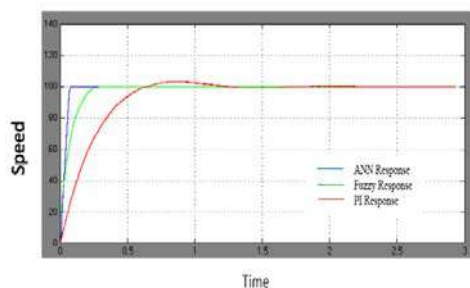
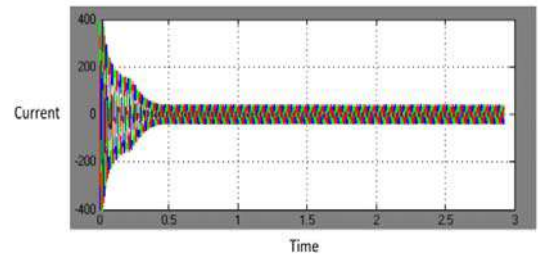
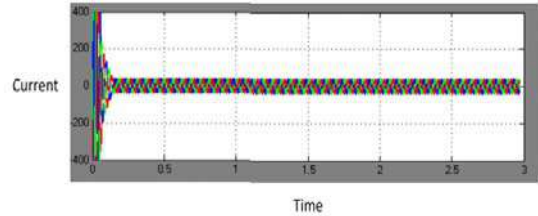

Fig.6 Speed response comparison at no-load



(a) PI



(b) Fuzzy

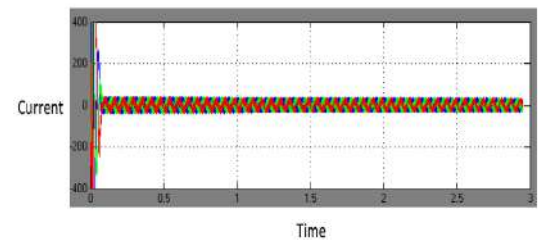

(c) Neural Network

Fig.7 Stator current comparison at no load

### 6. Conclusion:

This paper introduces indirect vector control of induction motor using intelligent techniques. It successfully demonstrates the application of fuzzy logic and neural network for vector controlled induction motor drive. Time response of PI controller is compared with fuzzy logic controller and neural network controller. Performance of Neural Network controller is better in terms of rise time. There is no overshoot in both fuzzy controller and Neural network controller. Also steady state error is acceptable for both the controller. Here the performance and reliability of induction motor is found better.

## 7. References:

- [1]. Bose B.K., "Modern Power Electronics and AC Drives", Prentice Hall
- [2]. Sanjiv Kumar, Bhim singh, J.K.chatterjee, "Fuzzy Logic based speed controller for vector controlled cage induction motor drive "IEEE 1998
- [3]. M. Zerikat, and S. Chekroun, "Design and Implementation of a Hybrid Fuzzy Controller for a High-Performance Induction Motor"
- [4]. Norman Mariun, Samsul Bahari Mohd Noor, Jasronita Jasni, Omar S. Bennanes  
"A Fuzzy logic based controller for vector controlled three-phase Induction motor".IEEE,2004
- [5]. K.M.Hasan, Li Zhang , B.Singh, "Neural Network Control of Induction Motor Drives for Energy Efficiency and High Dynamic Performance"
- [6]. A. K. Sharma, R. A. Gupta, and Laxmi Srivastava," Implementation of neural network in Energy saving of induction motor drives with indirect vector"
- [7]. M. Godoy Simces, Bimal K. Bose, "Neural Network Based Estimation of Feedback Signals for a Vector Controlled Induction Motor Drive"
- [8]. [www.mathwork.com](http://www.mathwork.com)

# Comparative Study of Web Services and Software oriented Architecture for Mobile Augmented Reality System

DR. Bijendra Agrawal<sup>1</sup> , Jatin Shah<sup>2</sup> ,

1.Principal, VKMS College,

2.MCA, Research Scholar,

Vadu

[jatinshah79mca@gmail.com](mailto:jatinshah79mca@gmail.com)

[bijendra\\_agrawal@yahoo.com](mailto:bijendra_agrawal@yahoo.com)

*Abstract:-SOA and Web Services are two buzzwords in the software industry now a days. Most of the people are confused about, What they are?. And they don't know the difference, they take them as synonyms. In this paper, we clearly show the difference between these two. Also the architecture of the Web Services in normal situation and architecture for web services based on SOA in terms of Mobile Augmented Reality System.*

## Introduction :

Einstein made that famous statement many decades ago, and it's still relevant today for building superior software systems. Unfortunately, as anyone who has been in the IT industry for long can point out, far too many software systems have failed Einstein's test. Some are made too simple to carry out the duties they are supposed to perform. Others are made too complex, and the costs of building and maintaining them have rocketed, not to mention the nearly impossible tasks of integrating different systems together. It seems that reaching the right level of simplicity is more like a dream than reality.

## Loose Coupling:

We don't have to look far to find the problems. As we build more and more software systems, we see similar situations and patterns appearing. Naturally, we want to reuse the functionality of existing systems rather than building them from scratch. A real dependency is a state of affairs in which one system depends on the functionality provided by another. If the world only contained real dependencies, Einstein's test would have been satisfied long time ago. The problem is that we also create artificial dependencies along with real dependencies.

If you travel overseas on business, you know that you must bring power adapters along with you or your life will be miserable. The real dependency is that you need power; the artificial dependency is that your plug must fit into the local outlet. Looking at all the varying sizes and shapes of those plugs from different countries, you would notice that some of them are small and compact while many others are big and bulky.

The lesson here is that we cannot remove artificial dependencies, but we can reduce them. If the artificial dependencies among systems have been reduced, ideally, to their minimum, we have achieved loose coupling. In that sense, Einstein was just talking about was loose coupling. We might rework his famous principle thus: "Artificial dependencies should be reduced to the minimum but real dependencies should not be altered."

## SOA Defined and Explained

Now we are able to define a Service Oriented Architecture (SOA). SOA is an architectural style whose goal is to achieve loose coupling among interacting software agents. A service is a unit of work done by a service provider to achieve desired end results for a service consumer. Both provider and consumer are roles played by software agents on behalf of their owners.

This sounds a bit too abstract, but SOA is actually everywhere. Let's look at an example of SOA which is likely to be found in your living room. Take a CD for instance. If you want to play it, you put your CD into a CD player and the player plays it for you. The CD player offers a CD playing service. Which is nice because you can replace one CD player with another. You can play the same CD on a portable player or on your expensive stereo. They both offer the same CD playing service, but the quality of service is different.

The idea of SOA departs significantly from that of object oriented programming, which strongly suggests that you should bind data and its processing together. So, in object oriented programming style, every CD would come with its own player and they are not supposed to be separated. This sounds odd, but it's the way we have built many software systems.

The results of a service are usually the change of state for the consumer but can also be a change of state for the provider or for both. After listening to the music played by your CD player, your mood has changed, say, from "depressed" to "happy". If you want an example that involves the change of states for both, dining out in a restaurant is a good one.



The reason that we want someone else to do the work for us is that they are experts. Consuming a service is usually cheaper and more effective than doing the work ourselves. Most of us are smart enough to realize that we are not smart enough to be expert in everything. The same rule applies to building software systems. We call it "separation of concerns", and it is regarded as a principle of software engineering.

How does SOA achieve loose coupling among interacting software agents? It does so by employing two architectural constraints:

1. A small set of simple and ubiquitous interfaces to all participating software agents. Only generic semantics are encoded at the interfaces. The interfaces should be universally available for all providers and consumers.
2. Descriptive messages constrained by an extensible schema delivered through the interfaces. No, or only minimal, system behavior is prescribed by messages. A schema limits the vocabulary and structure of messages. An extensible schema allows new versions of services to be introduced without breaking existing services.

As illustrated in the power adapter example, interfacing is fundamentally important. If interfaces do not work, systems do not work. Interfacing is also expensive and error-prone for distributed applications. An interface needs to prescribe system behavior, and this is very difficult to implement correctly across different platforms and languages. Remote interfaces are also the slowest part of most distributed applications. Instead of building new interfaces for each application, it makes sense to reuse a few generic ones for all applications.

Since we have only a few generic interfaces available, we must express application-specific semantics in messages. We can send any kind of message over our interfaces, but there are a few rules to follow before we can say that an architecture is service oriented.

First, the messages must be descriptive, rather than instructive, because the service provider is responsible for solving the problem. This is like going to a restaurant: you tell your waiter what you would like to order and your preferences but you don't tell their cook how to cook your dish step by step.

Second, service providers will be unable to understand your request if your messages are not written in a format, structure, and vocabulary that is understood by all parties. Limiting the vocabulary and structure of messages is a necessity for any efficient communication. The more restricted a message is, the easier it is to understand the message, although it comes at the expense of reduced extensibility.

Third, extensibility is vitally important. It is not difficult to understand why. The world is an ever-changing place and so is any environment in which a software system lives. Those changes demand corresponding changes in the software system, service consumers, providers, and the messages they exchange. If messages are not extensible, consumers and providers will be locked into one particular version of a service. Despite the importance of extensibility, it has been traditionally overlooked. At best, it was regarded simply as a good practice rather than something fundamental. Restriction and extensibility are deeply entwined. You need both, and

increasing one comes at the expense of reducing the other. The trick is to have a right balance.

Fourth, an SOA must have a mechanism that enables a consumer to discover a service provider under the context of a service sought by the consumer. The mechanism can be really flexible, and it does not have to be a centralized registry.

## Purpose of the Web Service Architecture

Web services provide a standard means of interoperating between different software applications, running on a variety of platforms and/or frameworks. This document (WSA) is intended to provide a common definition of a Web service, and define its place within a larger Web services framework to guide the community. The WSA provides a conceptual model and a context for understanding Web services and the relationships between the components of this model.

The architecture does not attempt to specify how Web services are implemented, and imposes no restriction on how Web services might be combined. The WSA describes both the minimal characteristics that are common to all Web services, and a number of characteristics that are needed by many, but not all, Web services.

The Web services architecture is an *interoperability* architecture: it identifies those global elements of the global Web services network that are required in order to ensure interoperability between Web services.

## What is a Web service?

A Web service is a software system designed to support interoperable machine-to-machine interaction over a network. It has an interface described in a machine-processable format (specifically WSDL). Other systems interact with the Web service in a manner prescribed by its description using SOAP messages, typically conveyed using HTTP with an XML serialization in conjunction with other Web-related standards.

## Agents and Services

A Web service is an abstract notion that must be implemented by a concrete agent. The agent is the concrete piece of software or hardware that sends and receives messages, while the service is the resource characterized by the abstract set of functionality that is provided. To illustrate this distinction, you might implement a particular Web service using one agent one day (perhaps written in one programming language), and a different agent the next day (perhaps written in a different programming language) with the same functionality. Although the agent may have changed, the Web service remains the same.

## Requesters and Providers

The purpose of a Web service is to provide some functionality on behalf of its owner -- a person or organization, such as a business or an individual. The *provider entity* is the person or organization that provides an appropriate agent to implement a particular service.

A *requester entity* is a person or organization that wishes to make use of a provider entity's Web service. It will use a *requester agent* to exchange messages with the provider entity's *provider agent*.

### Service Description

The mechanics of the message exchange are documented in a Web service description (WSD). The WSD is a machine-processable specification of the Web service's interface, written in WSDL. It defines the message formats, data types, transport protocols, and transport serialization formats that should be used between the requester agent and the provider agent. It also specifies one or more network locations at which a provider agent can be invoked, and may provide some information about the message exchange pattern that is expected. In essence, the service description represents an agreement governing the mechanics of interacting with that service.

### Semantics

The semantics of a Web service is the shared expectation about the behavior of the service, in particular in response to messages that are sent to it. In effect, this is the "contract" between the requester entity and the provider entity regarding the purpose and consequences of the interaction. Although this contract represents the overall agreement between the requester entity and the provider entity on how and why their respective agents will interact, it is not necessarily written or explicitly negotiated. It may be explicit or implicit, oral or written, machine processable or human oriented, and it may be a legal agreement or an informal (non-legal) agreement. While the service description represents a contract governing the mechanics of interacting with a particular service, the semantics represents a contract governing the meaning and purpose of that interaction. The dividing line between these two is not necessarily rigid. As more semantically rich languages are used to describe the mechanics of the interaction, more of the essential information may migrate from the informal semantics to the service description. As this migration occurs, more of the work required to achieve successful interaction can be automated.

There are many ways that a requester entity might engage and use a Web service. In general, the following broad steps are required, (1) the requester and provider entities become known to each other (or at least one becomes know to the other); (2) the requester and provider entities somehow agree on the service description and semantics that will govern the interaction between the requester and provider agents; (3) the service description and semantics are realized by the requester and provider agents; and (4) the requester and provider agents exchange messages, thus performing some task on behalf of the requester and provider entities. (I.e., the exchange of messages with the provider agent represents the concrete manifestation of interacting with the provider entity's Web service.) Some of these steps may be automated, others may be performed manually.

### The Architectural Models

This architecture has four models, illustrated in. Each model in is labeled with what may be viewed as the key concept of that model.

The four models are:

1) The Message Oriented Model focuses on messages, message structure, message transport and so on — without particular reference as to the reasons for the messages, nor to their significance.

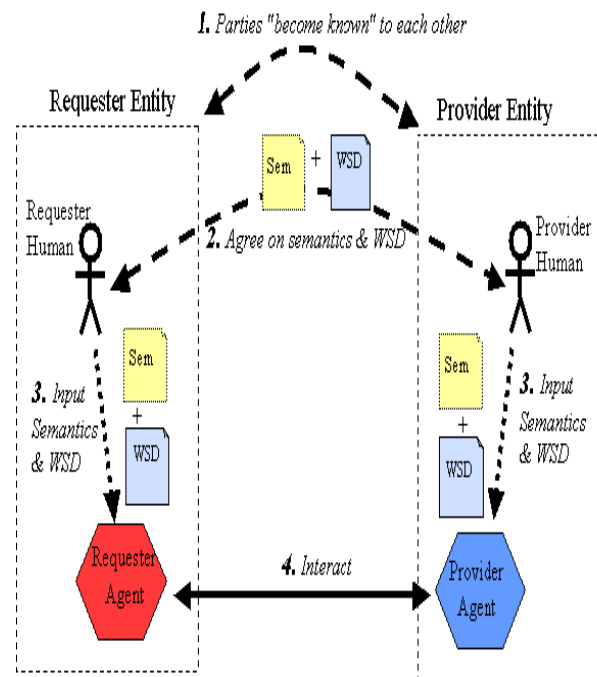
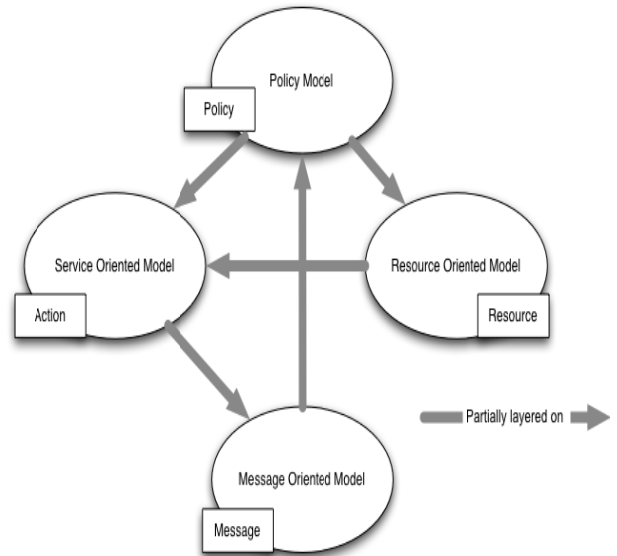

The essence of the message model revolves around a few key concepts illustrated above: the agent that sends and receives messages, the structure of the message in terms of message headers and bodies and the mechanisms used to deliver messages. Of course, there are additional details to consider:

the role of policies and how they govern the message level model. The abridged diagram shows the key concepts; the detailed diagram expands on this to include many more concepts and relationships.

2) The Service Oriented Model focuses on aspects of service, action and so on. While clearly, in any distributed system, services cannot be adequately realized without some means of messaging, the converse is not the case: messages do not need to relate to services.

The Service Oriented Model is the most complex of all the models in the architecture. However, it too revolves around a few key ideas. A service is realized by an agent and used by another agent. Services are mediated by means of the messages exchanged between requester agents and provider agents.

A very important aspect of services is their relationship to the real world: services are mostly deployed to offer functionality in the real world. We model this by elaborating on the concept of a service's owner — which, whether it is a person or an organization, has a real world responsibility for the service.

Finally, the Service Oriented Model makes use of meta-data, which, as described in **Service Oriented Architecture**, is a key property of Service Oriented Architectures. This meta-data is used to document many aspects of services: from the details of the interface and transport binding to the semantics of the service and what policy restrictions there may be on the service. Providing rich descriptions is key to successful deployment and use of services across the Internet.

3) The Resource Oriented Model focuses on resources that exist and have owners.

The resource model is adopted from the Web Architecture concept of resource. We expand on this to incorporate the relationships between resources and owners.

4) The Policy Model focuses on constraints on the behavior of agents and services. We generalize this to resources since policies can apply equally to documents (such as descriptions of services) as well as active computational resources.

Policies are about resources. They are applied to agents that may attempt to access those resources, and are put in place, or established, by people who have responsibility for the resource.

Policies may be enacted to represent security concerns, quality of service concerns, management concerns and application concerns.

### **Conclusion:**

The web services approach is based on a maturing set of standards that are widely accepted and used. This widespread acceptance makes it possible for clients and services to communicate and understand each other across a wide variety of platforms and across language boundaries. Design architecture for mobile augmented Reality System SOA based Web Services played vital role due to the limitation of mobile device.

### **References:**

<http://www.w3.org/TR/2004/NOTE-ws-arch-20040211/>

<http://www.w3.org/TR/ws-arch/>

<http://www.w3.org/TR/2003/WD-ws-arch-20030808/>

[www.service-architecture.com](http://www.service-architecture.com)

<http://www.w3c.org/2002/ws/arch>

Web Services and Service-Oriented Architectures: The Savvy Manager's Guide  
by Douglas K. Barry

# QUEST (Quick Unbiased Efficient Statistical Tree): An efficient algorithm of Classification Tree in Data Mining

<sup>1</sup>Mr. U. N. Parmar, <sup>2</sup>Mr. A. K. Ranpura, <sup>3</sup>Mr. V. K. Jadeja, <sup>4</sup>Mr. R. P. Joshi  
<sup>1,3,4</sup>Lecturer, Dept of IT, CCET, Wadhwan, Gujarat., <sup>2</sup>Lecturer, MCA Dept, CCET, Wadhwan, Gujarat.  
ureshparmar13@yahoo.co.in, [ranpura.avalik.2007@gmail.com](mailto:ranpura.avalik.2007@gmail.com), [vkjadeja\\_itworld@yahoo.co.in](mailto:vkjadeja_itworld@yahoo.co.in), [rah1985@gmail.com](mailto:rah1985@gmail.com)

**Abstract:-** Classification trees based on exhaustive search algorithms tend to be biased towards selecting variables that afford more splits. As a result, such trees should be interpreted with caution. In this paper QUEST (QUICK UNBIASED EFFICIENT STATISTICAL TREE) algorithm is proposed which has negligible bias. Its split selection strategy yields binary splits and the final tree can be selected by a direct stopping rule or by pruning. Real and simulated data are used to compare QUEST with the exhaustive search approach. QUEST is shown to be substantially faster as QUEST generates random no. of trees like forests and the size and classification accuracy of its trees are typically comparable to those of exhaustive search. QUEST classifies the data from dataset file like ARFF. QUEST works with categorical as well as continuous attributes. QUEST gives the better result compare to other existing classifiers such as SimpleCart, ID3, J48 etc. QUEST gives the statistical binary decision tree. It is the tree structured classification algorithm which gives the efficient tree. QUEST also does pruning and deals with missing values using cross validation. QUEST uses the univariate splits to split the node instead of surrogate splits. This thesis gives detailed description about the QUEST algorithm.

## 1. INTRODUCTION

In Data Mining, many Decision Tree classification methods are available. But each method has some drawback. The basic decision tree method ID3, which can easily generate the tree but neither prune the tree nor deals with missing values. Same way CHAID generates non binary decision tree but takes time to generate the tree. First the basic decision tree algorithm ID3 has been found. But it was having many disadvantages. So many new decision tree algorithms were enhanced from basic and some problems can be solved by new algorithms. But day by day data becomes larger. So there is a need to classify the data from large dataset quickly with good accuracy. QUEST which stands for QUICK UNBIASED EFFICIENT STATISTICAL TREE can classify data more quickly and with low cost because QUEST has negligible bias. So by using QUEST algorithm the problem of classifying data quickly from large dataset can be easily solved. QUEST generates a binary decision tree; therefore it is easy to classify the data using QUEST [3] [5].

QUEST uses statistical imputation instead of surrogate splits as in CART. For both ordered variable and categorical variable, different split point selection method is used. [3]. QUEST also deals with missing values. QUEST is based on statistics; therefore it uses imputation for missing values. are two methods- Hot Deck imputation and Regression imputation. Hot-deck imputation fills in missing values on incomplete records using values from similar, but complete records of the same dataset. Regression computation is commonly used when auxiliary data are available. [8][7]

The QUEST algorithm can be used in applications such as Medical Research, Chemical Laboratory, Food Chemistry, Weather Forecasting, Neural Network etc.

## 2. CONCEPT OF CLASSIFICATION

Classification is a data mining (machine learning) technique used to predict group membership for data instances. Classification and prediction are two form of data analysis that can be used to extract models describing important data classes or to predict future data trends for which the classifiers are used [9].

### 2.1 Classification Methods

#### 2.1.1 Decision Tree

A decision tree is a flow chart like tree structure in which each branch (nonleaf) node represents a choice between a number of alternatives, and each leaf (terminal) node represents a classification or decision. A decision tree can be used to classify an example by starting at the root of the tree and moving through it until a leaf node, which provides the classification of the instance.

Decision Trees are so popular just because, its construction does not require any domain knowledge or parameter setting, and is appropriate for exploratory knowledge discovery. Decision trees can handle high dimensional data. Their representation of acquired knowledge in tree form is intuitive easy to assimilate. The learning and classification steps of decision tree induction is simple and fast. In general Decision Tree classifiers have good accuracy.

In advantages of Decision Trees it can handle both nominal and numeric input attributes, can handle datasets that may have errors, handle datasets having missing values, it may reduce cost even if the cost of classification is high and no need of domain knowledge.

In disadvantages of Decision tree that most of its algorithms have discrete values as target values, reduce performance in complex interactive attributes, sometimes provide over-sensitivity to the training set, and sometimes deteriorate when handling too much missing values.

### 2.1.2 Binary Decision Tree

Binary Decision Trees (BDTs) are essentially computer science binary tree structures, enabling a conclusion state to be reached from a root node (which you could think of as a question or decision choice) via a set of binary (yes/no) decision states. In more down-to-earth terms, it is a technique to allow a conclusion to be made based on a specified problem definition. Decision trees are a popular technique in classification systems as well as in computer game AI and there are a whole host of related algorithms of interest, e.g. ID3. A BDT comprises of a set of body nodes which are attached to a root node and which terminate at n leaf nodes. The root and each body node must have connections to two other nodes; otherwise they are classed as terminating nodes where a decision outcome state has been reached. The uniform design of the tree based on two nodes leads to it being called a binary decision tree.

The leaf nodes in a BDT represent a set of terminating "answers" or decision outcome states as I have called them, the root and body nodes representing the "questions". The BDT arrives at a decision state by gaining answers to the body (yes/no) nodes. The nature of the response to a particular question dictates which node should be followed to the next question (or answer if a leaf node is arrived at). In the case of a binary decision tree the responses can only be "yes" or "no", each corresponding to one of the two available branches at each body node.

### 2.1.3 Various Advanced Decision Trees

**1. ID3:** The ID3 algorithm is considered to be very simple decision tree algorithm. Using information gain as splitting criteria, ID3 ceases to grow when all instances belong to a single value of a target feature or when best information gain is not greater than zero. ID3 does not apply any pruning process nor handles missing values.

**2. C4.5:** It is an evolution of ID3 which uses gain ratio as splitting criteria. The splitting ceases when number of instances to be split is below a certain threshold. Error based pruning is performed after the growing phase. C4.5 can handle numeric attributes. It can also induce from the training set that incorporates missing values by using corrected gain ratio criteria.

**3. CART:** CART stands for Classification and Regression tree. CART partitions the data into two subsets so that the records

within each subset are more homogeneous than in the previous subset. It is a recursive process—each of those two subsets is then split again, and the process repeats until the homogeneity criterion is reached or until some other stopping criterion is satisfied. It also enables users to provide prior probability distribution.

**4. CHAID:** A CHAID stands for Chi Squared automatic interaction detection was originally designed to handle nominal attributes only. CHAID evaluates all of the values of a potential predictor field. It merges values that are judged to be statistically homogeneous (similar) with respect to the target variable and maintains all other values that are heterogeneous (dissimilar). CHAID "build" non-binary trees based on a relatively simple algorithm that is particularly well suited for the analysis of larger datasets.

**5. QUEST:** It is a relatively new binary tree-growing algorithm (Loh and Shih, 1997). It deals with split field selection and split-point selection separately. The univariate split in QUEST performs approximately unbiased field selection. That is, if all predictor fields are equally informative with respect to the target field, QUEST selects any of the predictor fields with equal probability. QUEST affords many of the advantages of CART, but, like CART, your trees can become unwieldy. You can apply automatic cost-complexity pruning to a QUEST tree to cut down its size. QUEST uses surrogate splitting to handle missing values.

## 3.COMMON CRITERIAS OF ANY TREE BASED CLASSIFICATION METHOD.

**Merging** – relative to the target variable, non-significant predictor categories are grouped with the significant categories.

**Splitting** – selecting the split point. Variable to split population is chosen by comparison to all others.

**Stopping** – rules which determine how far to extend the splitting of nodes.

**Pruning** – branches that add little to the predictive value of the tree are removed.

## 4. QUEST ALGORITHM

**Algorithm:** Generate a binary decision tree using QUEST Algorithm

**Input:**

- Dataset D, which is a set of training tuples and their associated class labels
- Attribute\_list, which is the set of candidate attributes
- Attribute\_selection Method, a procedure used to split the node and partition the data into individual classes.

**Output:** A Statistical Binary Decision Tree

**Method:**

1. Create the Root node R
2. If tuples in D are all of the same class c, then return R as a leaf node labeled with the class C
3. If attribute\_list is empty then return R as a leaf node labeled with the majority class in D
4. Else Association between each input attribute and target attribute is computed using ANOVA-F test if attribute is ordinal or Chi-square test if attribute is categorical
5. If attribute is multi nominal then clustering is used to create two super classes. The attribute that obtains the highest association with the target attribute is selected for splitting.
6. Apply the stopping criteria
7. Prune the tree using Pre-pruning or Post-pruning.
8. Apply ten fold cross validation to deal with Missing values
9. Output the binary decision tree

**Fig 1. The QUEST Algorithm**

QUEST (Quick, Unbiased, Efficient, Statistical Tree) is a binary-split decision tree algorithm for classification and data mining technique. The objective of QUEST is similar to that of the CART (classification and Regression) algorithm but the major differences are:

- QUEST uses an unbiased variable selection technique by default
- QUEST uses imputation instead of surrogate splits to deal with missing values.
- QUEST can easily handle categorical predictor variables with many categories

A *variable selection scheme* is proposed for constructing multivariate classification trees. It utilizes conditional independence test derived from hierarchical log linear model for three-way contingency table to control selection bias. Furthermore, it is compared with some existing selection methods in terms of selection power. Simulation results show that our method is unbiased and has better selection power.

QUEST is shown to be substantially faster and the size and classification accuracy of its trees are QUEST that

- 1) has negligible variable selection bias
- 2) Retains the computational simplicity of FACT technique
- 3) Includes pruning as an option
- 4) Yields binary splits

QUEST method is demonstrated to be much better than exhaustive search in terms of variable selection bias and computational cost.

QUEST is a tree-structured classification algorithm that yields a binary decision tree like CART. The reason for yielding a binary tree is that a binary tree may allows techniques such as *pruning, direct stopping rules and surrogate splits* to be used. Unlike CHAID and CART, which handle variable selection and split point selection simultaneously during the tree growing

process. QUEST was demonstrated to be much better than exhaustive search methods in terms of variable selection bias and computational cost. In terms of classification accuracy, variability of split points and tree size, however, there is still no clear winner when univariate splits are used.

For each split, the association between each input attribute and the target attribute is computed using the ANOVA-F test or Leven's test(for ordinal and continuous attribute) or Pearson's Chi-Square (for nominal attribute). An ANOVA F-statistics is computed for each attribute. If the largest F-statistics exceeds a predefined threshold value, the attribute with the largest F-value is selected to split the node. Otherwise, leven's test for unequal variance is computed for every attribute. If the largest levene is greater than a predefined threshold value, the attribute with the largest levene value is used to split the node..

If the target attribute is multinomial, two means clustering is used to create two super-classes. The attribute that obtains the highest association with the target attribute is selected for splitting.

**4.1 Advantages of QUEST Algorithm compared to other Decision Tree Algorithms**

- Variable selection Bias
- Computational Accuracy/Computational cost
- Variability of split points & Tree size
- QUEST is shown to be substantially faster and the size and classification accuracy of its trees are comparable to these of exhaustive search.

**4.2 Components of QUEST analysis**

Basic components in a QUEST analysis are as follows:

- *One or more predictor variable:* Predictor variables can be continuous, ordinal or nominal variables.
- *One target variable:* The target variable must be nominal.
- *Settings for various QUEST parameters:* The settings include alpha level for variable selection, priors for the categorical target variable, profit values and misclassification costs, and the variable used as the frequency weight variable.

**4.3 Comments on QUEST analysis**

- With categorical dependent variables only.
- If it is important to have an unbiased tree.
- If you have a large or complex data set and need an efficient algorithm for estimating the tree.
- Or CART, if you want to restrict your tree to binary splits.
- If the classification model produced by QUEST is measurably better than that produced by the other methods.
- CART to handle missing values by surrogate splits.
- Case weight is ignored in the QUEST option.

Like CHAID, the cost matrix is not directly involved in the

QUEST tree growing process.

However, for a symmetric cost matrix, cost information can be incorporated into the model by adjusting the priors based on the cost matrix.

#### 4.4 Stopping Rules

Each of the methods recursively splits nodes until one of the stopping rules is triggered.

The following conditions will cause the algorithm to terminate:

- The maximum tree depth has been reached.
- No more splits can be made, because all terminal nodes meet one or more of the following conditions:
- There is no significant predictor variable left to split the node.
- The number of cases in the terminal node is less than the minimum number of cases for parent nodes.

#### 4.5 Dealing with missing values

QUEST uses *statistical imputation* instead of surrogate splits while handling missing values.

Surrogate splitters are used to classify rows that have missing values in the primary splitter. When a row is encountered that has a missing value on the primary splitter.

#### Data Imputation for Missing Values

Two of the most commonly used techniques by QUEST for data imputation are *hot-deck imputation* and *regression imputation*.

**Hot-deck imputation** fills in missing values on incomplete records using values from similar, but complete records of the same dataset.

**Regression imputation** is commonly used to compensate for item non response when auxiliary data are available. It is common practice to compute survey estimators by treating imputed values as observed data and using the standard unbiased (or nearly unbiased) estimation formulas designed for the case of no non response.

### 5. EXPERIMENTS AND RESULT

To evaluate the performance of the QUEST we are using some of the well known UCI (University of California Irvine) datasets [10]. The performance of the classification-based method is affected by several factors such as the number of records, the number of attributes, the number of records on which model is built, amount of missing values etc.

Table1 describes the three different UCI datasets with number of instances that we have used for performance study.

Dataset	No of Instances
Soybean	5000
Mushroom	9000
Waveform	10000

**Table 1. Summary of datasets**

The QUEST algorithm's performance is tested & compared with other existing algorithms such as J48, DecisionStump,

SimpleCart. Compared to other algorithms, QUEST is giving better accuracy. The comparison using Soybean dataset is given in table 2 and relevant graph is given in fig 2.

Classifier	Accuracy(Soybean)
QUEST	93.41
J 48	91.50
Decision Stump	28
Simple Cart	91.21

**Table 2. Classifier vs Accuracy**

We have also done comparison with Mushroom and Waveform datasets with different number of instances. We found that most of the cases QUEST giving better result.

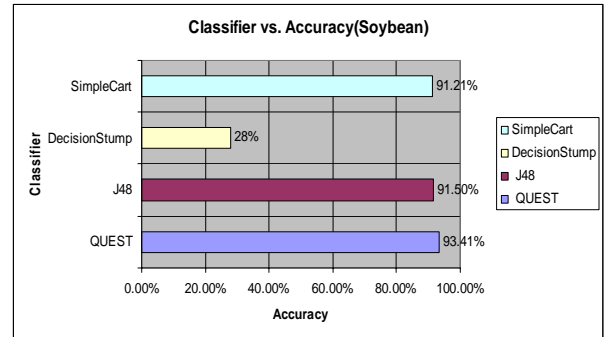

**Figure 2. Comparison of different classifiers' accuracy on Soybean dataset using WEKA tool. (Accuracy shows in percentage). The x-cordinates shows the accuracy, y-cordinates shows classifiers.**

### 6. CONCLUSION

This paper comprehensively shows how the QUEST algorithm being run and also done the comparison of QUEST with other classifiers with large datasets. So we can conclude that with negligible bias, binary split strategy and stopping rules, QUEST generating attractive results as compare with other classifier trees.

## 7. REFERENCE

- [1] Narsimha Raju Alluri : “Evaluation of Data Mining Methods to support Data Warehouse Administration”, University of Applied Sciences, Furtwangen-Germany, 2005.
- [2] Wei Peng, Juhua Chen and Haiping Zhou: “An Implementation of ID3 Algorithm”, University of New South Wales, Sydney-Australia, 1997
- [3] Wei-Yin Loh and Yu-Shan Shih: “Split selection Methods for Classification Trees”, University of Wisconsin-Madison, 1997.
- [4] Mike Cameron-Jones and Andrew Charman-Williams: “Stacking for Misclassification Cost Performance”, University of Tasmania, Australia, 1999.
- [5] Loh and Shih: “Comparison of Old and New Classification Algorithms”, Machine learning 2000.
- [6] Yu Shan Shih: “QUEST User Manual”, National Chung Cheng University, Taiwan, 2004.
- [7] Hendrik Blockeel & Jan Struyf: “Efficient algorithms for Cross Validation”, Katholieke University, Belgium, 2002.
- [8] Paul E. Utgoff, Neil C. Berkman, “Decision Tree Induction Based on Efficient Tree Restructuring” Clouse Department of Computer Science, North Carolina A&T State University, Greensboro, NC 27411.
- [9] U N Parmar, A K Ranpura, S J Agravat, “Multiple Classifier System using bagging method”, vol 4, issue 1, IJTES international journal, Sangli, Jan 2010.
- [10] Machine learning UCI dataset repository  
<http://www.ics.uci.edu/mllearn/MLRepository.html>



# Performance Analysis of Gun-shot Direction Detection System for ak47 gun shot

<sup>1</sup>Anju M. Vasdewani <sup>2</sup>Dr. G.R.kulkarni <sup>3</sup>R.S.Gajre

<sup>1</sup> Student, M.E. (E.C.), C.U.Shah College of Engineering & Technology, Wadhwan City

<sup>2</sup>Principial, C.U.Shah College of Engineering & Technology, Wadhwan City

<sup>3</sup>Asst.Prof of Electronics & Communication Department

[amvasdewani@aits.edu.in](mailto:amvasdewani@aits.edu.in) [grkulkarni29264@rediffmail.com](mailto:grkulkarni29264@rediffmail.com) [rakeshgajre@gmail.com](mailto:rakeshgajre@gmail.com)

**ABSTRACT:-THIS SYSTEM CAN DETECT THE SOURCE OF GUN FIRE. THE WORKING PRINCIPLE OF THE SYSTEM IS THAT SOUND WAVES TRAVEL AT FINITE SPEED AND A SINGLE SOUND PICKED UP BY MULTIPLE MICROPHONES SPATIALLY DEPLOYED, WOULD BE OFFSET IN TIME. IN SIMPLE PARLANCE, THE MICROPHONE WHICH IS NEAREST TO THE SOUND SOURCE WILL PICK UP THE SOUND FIRST AND THAT WHICH IS FARTHEST WILL BE THE LAST TO HEAR IT. TO MAKE THE USE OF THIS PRINCIPLE IN A PRACTICABLE GADGET, NUMEROUS MICROPHONES ARE PLACED IN SPECIFIC MANNER IN TWO PLANES AND THE OUTPUT OF EACH MICROPHONE IS CONNECTED TO A PROCESSING CIRCUIT. THE PROCESSING CIRCUIT HAS TO ACCOMPLISH SOME VERY IMPORTANT TASKS. THE FIRST WOULD BE TO AUTHENTICATE THE SOUND AS A AK47 GUN SHOT AND TO STOP THE SYSTEM FROM GENERATING FALSE ALARMS WHEN IT PICKS UP A FIRE CRACKER OR A TIRE BURST. TO DO THIS SOUND COMPARISON ALGORITHM IS BEING IMPLEMENTED USING MATLAB. ONCE THIS IS DONE THE REST OF THE PROCEDURE IS VERY STRAIGHT FORWARD. THE DELAY BETWEEN TWO MICROPHONES IN HORIZONTAL PLANE WILL DETERMINE THE DIRECTION OF GUN FIRE.THE INSTRUMENT CAN BE A GREAT HELP TO THE MILITARY AND OTHER SECURITY FORCES ON PATROL. SUCH AN INSTRUMENT WOULD BE A BOON TO SECURITY FORCES IN SURVIVING GUERILLA ATTACKS IN MILITANCY INFLECTED AREAS SUCH AS THE KASHMIR VALLEY AND THE EASTERN STATES. THE DISPLAY OF THE SYSTEM CAN BE CONSTRUCTED IN ANY WAY AS THE USER WOULD LIKE IT FOR INSTANCE IF THE MILITARY IS ABOUT TO USE IT, A PREFERABLE DISPLAY WOULD BE A CLOCK LIKE DIAL WITH LEDs MOUNTED AT DIFFERENT 'O CLOCKS' WITH WHICH THEY ARE VERY FAMILIAR ALONG WITH SOME AUDIO WARNING. IN SUCH A SYSTEM IF THE SYSTEM DETECTS THAT A SHOT HAS BEEN FIRED FROM THE FRONT THE 12 O CLOCK LED WILL LIGHT UP. THIS SYSTEM CAN ALSO BE MOUNTED ON PATROLLING VEHICLES.**

## Field of the Invention

The present invention generally relates to gunshot detection. More particularly, the present invention is directed to using multiple installations of sound detection, recording devices for detecting firing of a gun or an explosion, identifying of a location of such firing or explosion, and of a possible suspect of such firing or explosion.

It would therefore be desirable to provide a system to detect a gunshot, determine the direction from which it was fired, and initiate recording of the area of the event immediately upon the event occurring.

Here the task is divided into three different parts

- 1) Comparing input signal(gun shot or other sound) with stored ak47 gun shot, which decides whether direction is to be detected or not
- 2) Using parallel port of computer for indication if input signal is gun shot. Direction detection hardware is going to

display direction only when input signal is gunshot and output of parallel port is 1.

3) Hardware of direction detection consists of 8 microphones, supported by 8 preamplifiers and monostable multivibrators. Output of all 8 multivibrator is provided to port of microcontroller, and based on which input comes first direction is detected.

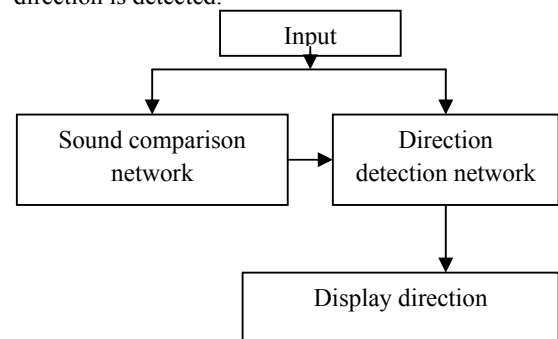

Figure 1: Layout of system

Figure 1 shows flow layout of system in which the whole task is divided into 2 portions. Signal comparison and direction detection. As shown in figure signal comparison loop and direction detection loop are working in parallel. When any input signal (acoustic in nature) comes, microphone that is connected to signal comparison loop picks up a sound and is given as an input to matlab for comparison purpose to decide whether input is ak47 or not. At a same time microphones connected to direction detection system would pick up sound and will determine direction as per input from which microphone is coming first. Result of direction is stored in one of the working register of direction detection circuit.

Direction detection circuit will not display the output till it will get input from signal comparison network. If input signal is ak47 then output of one parallel port line is given to direction detection circuit to inform that input was ak47. Then direction will be displayed.

## Comparison of input signal

First task is to compare input signal with pre stored gun shot signal continuously. Using wavread command, matrix of stored signal is generated and using wavrecord command matrix of input signal is generated. Then using algorithm for comparison between two sounds their similarity is checked.

Comparison between two signals(audio signals) can be done using cross correlation which is the basic method of comparing frequency components of two signals. Figure 2 shows original ak47 signal and figure 3 shows recorded signal.

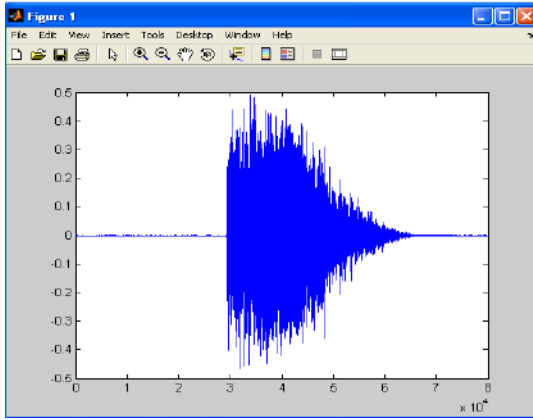

Figure 2: Original ak47 signal

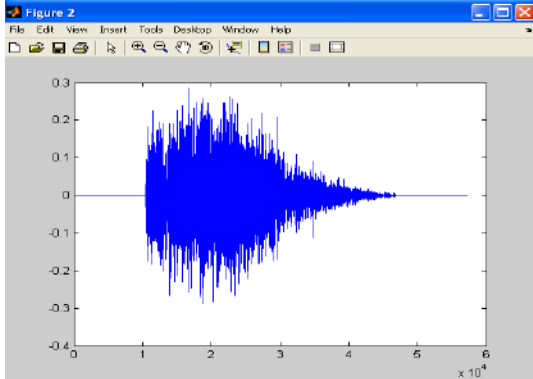

Figure 3: Recorded ak47 signal

As shown in above case as microphone was very near to source of gunshot there is 82.252% of cross correlation between input and stored sound.

Similarly table 1 shows cross correlation factor of original ak47 sounds with other signals. Here based on user's accuracy requirement system parameter for accuracy can be modified. It can be easily achieved that if cross correlation factor is greater than some threshold level then output of parallel port will be high other wise it will be low.

Another requirement of real time system is time required for processing should be as small as possible other wise if processing time is more then, required task of pointing suspected region ( if this system is used for security) can not be achieved. Processing time can only be reduced by doing some signal processing on input signal. For example if input signal is below some threshold and that can be defined by range of device. So that if input is less than some threshold, direction will not be displayed.

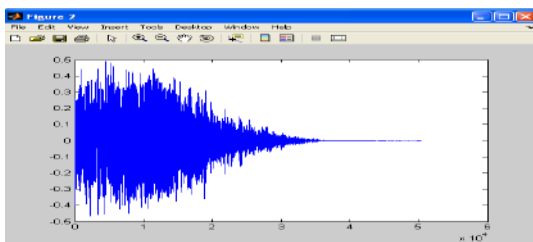

Figure 4: Truncated part of original ak47

Suppose ak47 is of 2 second signal, then recording cannot be done for exactly 2 second but more than 2 seconds. Solution to above problem can be achieved by truncating the portion which is below some threshold level so comparison time required will be less. Here figure 2 shows original ak47 and figure 3 shows recorded ak47. Direction comparison between them requires atleast 6 minutes to check whether recorded signal is ak47 or not, whereas comparison between their truncated part as shown in figure 4 and figure 5 respectively requires only 1 minute and 18 seconds for comparison purpose.

Other sound	Crosscorrelation(%)
Ak47	100
Ak47b	82.252
Ak47l	44.917
Explo	3.7
Explob	3.8
Gs	6.09
Gsb	6.149
Spoken word	6.88

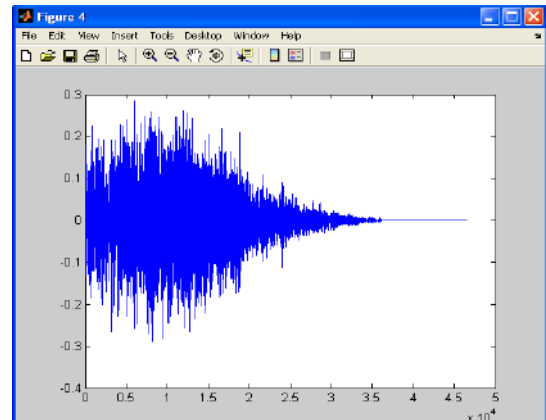

Figure 5: Truncated part of recorded ak47

## SYSTEM FOR DIRECTION DETECTION

### Introduction

Presently I have devised a system that senses direction with the help of only two microphones. Later I intend to construct a system that uses eight microphones to sense the direction of the sound source from all the four directions. The block diagram of the system is as shown in Figure 6. The sound is picked up simultaneously by the two condenser microphones for direction detection and one dedicated microphone having good frequency response is used as an input transducer for recording purpose and comparison purpose for computer. The outputs of these microphones are quite low and thus are amplified by their corresponding identical pre amplifiers. These amplified signals are used to trigger two different monostables. Both these monostables have identical time periods. The outputs of these monostables are used to provide interrupt to the microcontroller. The output of the system is a clock dial type led display which is driven by the controller port which has been configured as the output port by the software.

Table 1: Cross correlation factor of ak47 with other sounds

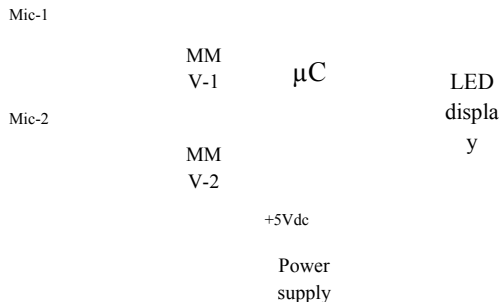

Figure 6: Block diagram of direction detection system using 2 microphones

Presently my system is working for two directions only i.e. north and south or it can be said that its resolution is 180 degree. Figure 7 shows flow chart of direction detection system.

As shown in figure 6 direction detection system is after initialization waiting for input. If there is any acoustic signal present then depending on place of gun fire (i.e. source of sound wave), LED will glow up for some time delay set using software. There are 2 basic problems if above system is used. They are as (1) If there are simultaneous gun shot from different direction then this system will not be able to distinguish whether source of gun fire is from which particular direction. (2) If gun fire is from center (i.e. all microphones receive signal of gun shot simultaneously) then based on which hardware having less propagation delay will generate output first, which gives wrong indication. (as here hardware for all sensors i.e. preamplifier, monostable multivibrator are constructed using same component value but practically due to tolerance they will not be same).

Figure 7: Flowchart of microcontroller based system for direction detection using 2 microphones

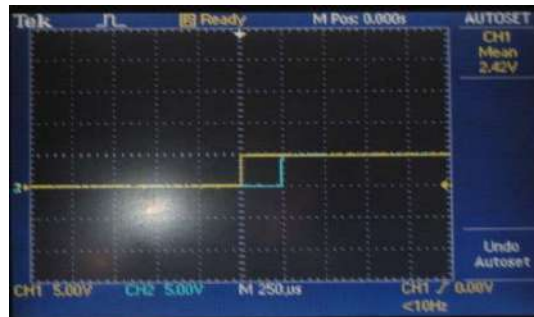
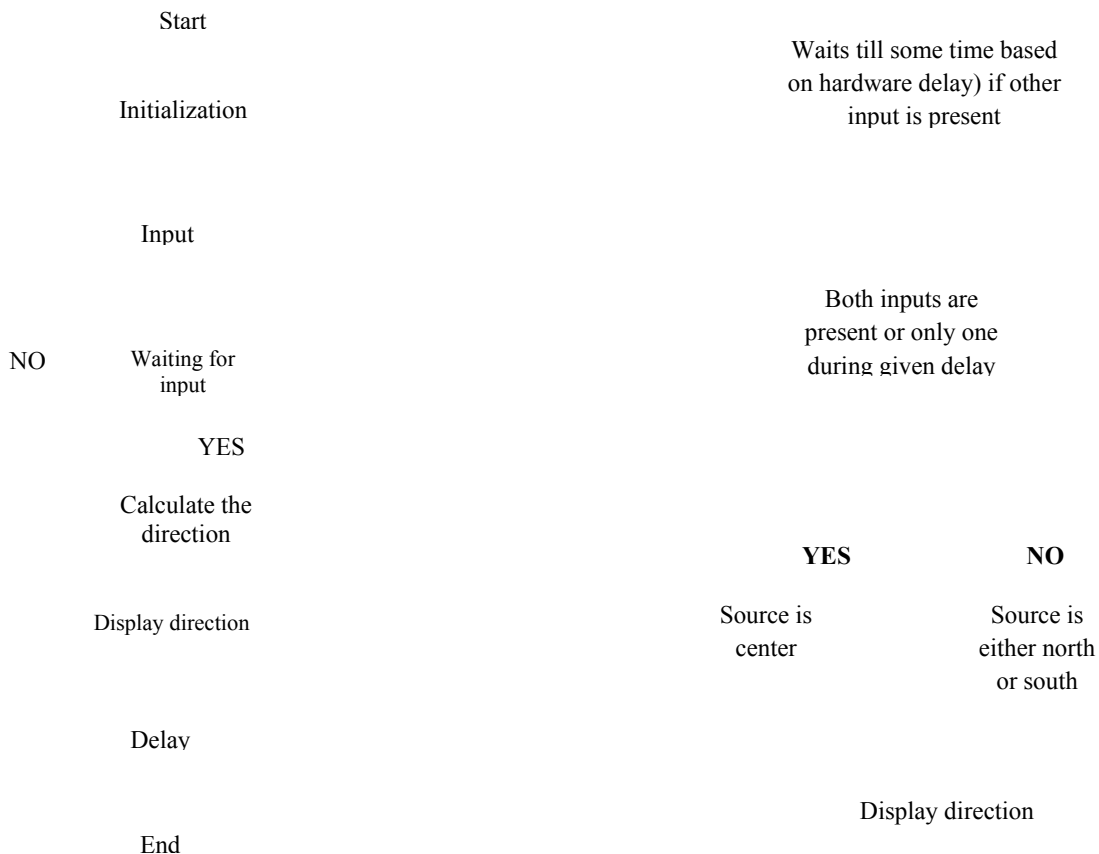

Figure 8: Propagation delay between of two similar hardware



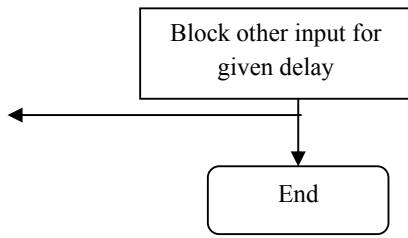

Figure 9: Flowchart of modified system

For solution of 1<sup>st</sup> problem one assumption is made i.e. for given delay only one gun shot can be detected.

If there are simultaneous gun fires then system will not be able to detect every gun shot but is limited to only some which depends what is the delay between gun shots. It is achieved by blocking the input for some time delay.

Solution to 2<sup>nd</sup> problem is made by finding propagation delay of two hardware; one which is faster compared to other is delayed using software technique. i.e. if input to both microphones comes during some prescribed time delay, then source is center other wise it is from any particular direction. Figure 8 shows time delay in two similar hardware measured using DSO.

Solution to above two problems is shown in figure 9 which shows flow chart for two microphone direction detection system. As stated above here another input is blocked after occurrence of one input for some time duration and to get correct center reading additional delay is added using software techniques.

## CONCLUSION

In this dissertation, I have proposed the basic issues in designing gun shot direction detection which is used for military and homeland security. The design has to very sensitive to decide whether gun shot detection was for ak47 so

that false direction detection can be prevented. Also while designing hardware for direction detection one has to think for critical timings of this system, as microcontroller (or any other processor) is responding in microseconds, so delay produced by each hardware should be equal., which challenges the component accuracy. Any change in time delay needs to corrected either in hardware or using software loop.

## REFERENCES

- 1 Muhammad Ali Mazidi, Janice Gillispie Mazidi, Rolin D. Mckinlay, "The 8051 Microcontroller and Embedded", Second Edition, Pearson Prentice Hall, 2006
- 2 Kenneth J. Ayala, "The 8051 Microcontroller Architecture, Programming & Applications", Second Edition, Penram International Publishing (India)
- 3 Lapin, Brett D., Besser, Nicholas D, "Gun shot digital imaging system", United states patent 6965541, 2005
- 4 [www.shotspotter.com](http://www.shotspotter.com)

# MODIFIED BAGGING METHOD: A NOVEL APPROACH OF MULTIPLE CLASSIFICATION IN DATA MINING

Mr. Uresh N Parmar<sup>1</sup> , Mr. Krunal G Patel<sup>2</sup>, Ms. Meenakshi<sup>3</sup>

1,2.Department of Information Technology,  
C.C.E.T, Wadhwan, Gujarat, India

3.Department of Information Technology  
K.I.T.R.C., Kalol, Gujarat, India

[meenakshi.saroha@gmail.com](mailto:meenakshi.saroha@gmail.com), [ureshparmar13@yahoo.co.in](mailto:ureshparmar13@yahoo.co.in)

**Abstract:**-Classification is the process of deriving unknown values of certain attributes of interest based on the values of the other attributes. Multiple classifier system (MCS) has shown to be an effective technique for classification. MCS construct a set of classifiers and then classify new data sets by taking votes of their prediction. Bagging is basically a multiple classifier ensemble based system improving the accuracy of the single base classifier learned on entire data, by using combination of models. In basic bagging approach, different bags (models) are created by sampling (with replacement) of the original training data set. Each bagged train set is independently used to generate a classifier, and classifier predictions are combined using as a simple majority voting system. However there is no guarantee that bagging will improve the performance of the base classifier every time, in some situations it fails to do so. Also bagging may work deterioratically in large dataset as well.

The main objective of the paper is to overcome the above defined problem, by using the same bootstrapping and aggregating method. Bagged predictors are constructed discarding the bootstrap samples which generate the accuracy which is less than the base classifier accuracy considering the involvement of the base classifier at the time combining all the models. The approach would be quite effective improving the accuracy of the base classifier as well as basic bagging classifier in a situation when bagging fails sometimes to do so.

## 1. INTRODUCTION

In matters of great importance that have financial, medical, social, or other implications, we often seek a second opinion before making a decision, sometimes a third, and sometimes many more. In doing so, we weigh the individual opinions, and combine them through some thought process to reach a final decision that is presumably the most informed one.

The process of consulting “several experts” before making a final decision is perhaps second nature to us; yet, the extensive benefits of such a process in automated decision making applications have only recently been discovered by computational intelligence community.

Also known under various other names, such as multiple classifier systems, committee of classifiers, or mixture of experts, ensemble based systems [2][3] have shown to produce favorable results compared to those of single-expert systems for a broad range of applications and under a variety of scenarios. Popular ensemble based algorithms, such as bagging, boosting, stacked generalization, and hierarchical mixture of experts.

A supervised machine learning task involves constructing a mapping from input data (normally described by several features) to the appropriate outputs. In a classification learning task, each output is one or more classes to which the input belongs. The goal of classification learning is to develop a model that separates the data into the different classes, with the aim of classifying new examples in the future.

Given a new example, the ensemble passes it to each of its multiple *base* models, obtains their predictions, and then combines them in some appropriate manner (e.g., averaging or voting).

## 4. CONCEPT OF BOOTSTRAPPING

Bootstrap is sampling with replacement from a sample. Bootstrapping is the practice of estimating properties of an estimator (such as its variance) by assuming set of observations to be from an independent and identically distributed population, this can be implemented by constructing a number of resamples of the observed dataset (and of equal size to the observed dataset), each of which is obtained by random sampling with replacement from the original dataset. It may also be used for constructing hypothesis tests. The advantage of bootstrapping over analytical methods is its great simplicity.

MCS is a meta-algorithm uses bootstrapping to improve machine learning of classification and regression models in terms of stability and classification accuracy.

### 3. CLASSIFIERS

Classification is a data mining (machine learning) technique used to predict group membership for data instances. Classification and prediction are two forms of data analysis that can be used to extract models describing important data classes or to predict future data trends for which the classifiers are used.

Basically two types of classifiers: Stable and Unstable. The most popular and commonly used stable classifiers are – Fisher Linear Discriminant (FLD) and Nearest Mean Classifier (NMC), and unstable are – Decision Tree, Decision Stumps [5]. MCS uses C4.5 Decision Tree Classifier as a base.

### 4. ENSEMBLE SYSTEM

An ensemble method for classification tasks constructs a set of base classifiers from the training data and performs classification by taking a vote on the prediction of each base classifier. Many traditional machine learning algorithms generate a single model (e.g., a decision tree or neural network). Ensemble learning methods instead generate multiple models.

#### 4.1 Reasons for using Ensemble Based System

There are several theoretical and practical reasons why we may prefer an ensemble system:

##### Statistical Reasons:

A set of classifiers with similar training performances may have different generalization performances. In fact, even classifiers with similar generalization performances may perform differently in the field.

##### Large Volumes of Data:

In certain applications, the amount of data to be analyzed can be too large to be effectively handled by a single classifier. Partitioning the data into smaller subsets, training different classifiers with different partitions of data and combining their outputs using an intelligent combination rule often proves to be a more efficient approach.

##### Too Little Data:

In the absence of adequate training data, resampling techniques can be used for drawing overlapping random subsets of the available data, each of which can be used to train a different classifier, creating the ensemble. Such approaches have also proven to be very effective.

##### Divide and Conquer:

Regardless of the amount of available data, certain problems are just too difficult for a given classifier to solve. More specifically, the decision boundary [3] that separates data from different classes may be too complex, or lie outside the space of functions that can be implemented by the chosen classifier model.

#### 4.2 Diversity

If we had access to a classifier with perfect generalization performance, there would be no need to resort to ensemble techniques. The realities of noise, outliers and overlapping data distributions, however, make such a classifier an impossible proposition. At best, we can hope for classifiers that correctly classify the field data *most of the time*. The strategy in ensemble systems is therefore to create many classifiers, and combine their outputs such that the combination improves upon the performance of a single classifier. This requires,

however, that individual classifiers make errors on different instances. The intuition is that if each classifier makes different errors, then a strategic combination of these classifiers can reduce the total error, a concept not too dissimilar to low pass filtering of the noise. The overarching principle in ensemble systems is therefore to make each classifier as unique as possible, particularly with respect to misclassified instances.

Classifier diversity [3] can be achieved in several ways. The most popular method is to use different training datasets to train individual classifiers. Such datasets are often obtained through resampling techniques, such as bootstrapping or bagging, where training data subsets are drawn randomly, usually with replacement, from the entire training data.

#### 4.3. Creating an Ensemble

Two interrelated questions need to be answered in designing an ensemble system: i) how will individual classifiers (base classifiers) be generated? And ii) how will they differ from each other? The answers ultimately determine the diversity of the classifiers, and hence affect the performance of the overall system.

Therefore, any strategy for generating the ensemble members must seek to improve the ensemble's diversity. In general, however, ensemble algorithms do not attempt to maximize a specific diversity measure. Rather, increased diversity is usually sought—somewhat heuristically—through various resampling procedures or selection of different training parameters. The above defined diversity measures can then be used to compare the diversities of the ensembles generated by different algorithms.

### 5. BAGGING METHOD

In data mining, a model generated by machine learning can be regarded as an expert. Expert is probably too strong a word – Depending on the amount and quality of the training data, and whether the learning algorithm is appropriate to the problem. An obvious approach to making decisions more reliable is to combine the output of different models. Several machine learning techniques do this by learning ensemble of models and using them in combination: prominent among these are schemes called bagging, boosting, and stacking. All are used to increase the predictive performance over a single model. And they are general techniques that can be applied to numeric prediction problems and to classification tasks [1].

The simplest way to do this in the case of the classification is to take the vote (majority vote); in the case of numeric prediction, it is calculating the average vote. So Bagging uses majority voting (for classification) or averaging (for numeric prediction) to combine the output of individual models.

Bagging is a statistical re-sample and combining technique used to reduce the misclassification error of a base classifier. It is based on *bootstrapping and aggregating* techniques.

## 6. BAGGING ALGORITHM

Input:

- D, a set of d training tuples;
- K, the number of models in the ensemble;
- A learning scheme (e.g. decision tree algorithm, back propagation, etc.)

Output: A composite model,  $M^*$ .

Method:

- for  $i = 1$  to  $k$  do // create  $k$  models
- create bootstrap sample,  $D_i$ , by sampling  $D$  with replacement;
- use  $D_i$  to derive a model,  $M_i$ ;
- endfor;

To use the composite model on a tuple,  $X$ :

- if classification then
- let each of the  $k$  models classify  $X$  and return the majority vote;
- if prediction then
- let each of the  $k$  models predict a value for  $X$  and return the average predicted value.

**Fig. 1. The Bagging Algorithm**

Given a set,  $D$ , of  $d$  tuples, bagging works as follows. For iteration  $i$ , ( $i = 1, 2, \dots, k$ ), a training set,  $D_i$ , of  $d$  tuples is sampled with replacement from the original set of  $D$  tuples. Note that the term Bagging stands for *bootstrap aggregation*. Each training set is a bootstrap sample. To classify an unknown tuple  $X$ , each classifier,  $M_i$ , returns its class prediction, which counts as one vote. The bagged classifier,  $M^*$ , counts the votes and assigns the class with the most votes to  $X$ . Bagging can be applied to the prediction for a given test tuple. The algorithm is summarized in the fig. 4.6. The increased accuracy occurs because the composite model reduces the variance of the individual classifiers.

Although the bagging algorithm has been known to be known in increasing the accuracy of prediction of the base unstable classifiers constructing bootstrap samples from training sets and then aggregating to form a final predictor, the main problem with this method is that *there is no guarantee that bagging will improve the performance of any base classifier every time* [1]. The other problem may arise when there is a large dataset of training tuples are there, in that case bagging would not be much effective.

## 7. MCS ALGORITHM

MCS is a modified bagging algorithm using C4.5 as a base classifier, aggregating the models discarding the classifier generating weak result.

The bootstrapping and aggregating is in following way.

- Input:**
- 1) A set of training tuples
  - 2) The number of models (bootstrap) in the ensemble
  - 3) A learning scheme (Decision Tree here)

**Output:** A composite model

**Method:**

- (1) Initialization of the training set & testing set from given data set.
- (2) Apply training data to the base learning, generate a model and calculate accuracy ( $ACC_{base}$ )
- (3) Repeat for number of times (as number of bootstrap)
  - (a) Create bootstrap sample, by sampling with replacement the original training set.
  - (b) Apply base learner on each bootstrap and calculate accuracy, ( $ACC_{boot}$ ).
  - (c) Compare  $ACC_{boot}$  with  $ACC_{base}$
  - (d) If  $ACC_{base} < ACC_{boot}$ 
    - (i) Consider base model as bootstrap model else
    - (ii) Consider bootstrap model
- (4) Calculate majority voting for classification and average accuracy for prediction

**Fig. 2. The MCS Algorithm**

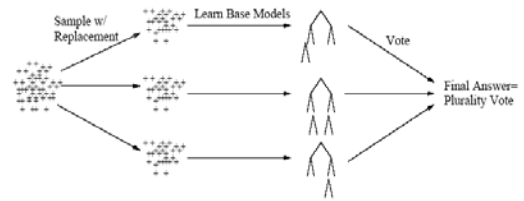

**Figure 3 The figurative view of the MCS algorithm**

The dataset is taken, and then it is divided into training set and testing set according to holdout method in which 2/3 of the set is taken as the training set and remaining 1/3 used as a testing set. Select the base learner classifier (here D.T.C4.5) and apply training data and calculate accuracy, which is called  $ACC_{base}$ .

Create number of bootstraps by doing sample with replacement method on the original training set. Take one bootstrap and apply base learner on it and generate accuracy,  $ACC_{boot}$ . Do this process for each of the bootstraps.

Now compare  $ACC_{boot}$  with  $ACC_{base}$ . if the accuracy of the bootstrap model is less than the accuracy of the base model, then at particular time the accuracy of the base model will be considered as a model for final decision, else the accuracy of the bootstrap model will be considered.

Calculate the majority voting method for better classification and aggregating for prediction.

## 8. EXPERIMENTS AND RESULTS

To evaluate the performance of the MCS we are using five of the well known UCI (University of California Irvine). The performance of the classification-based method is affected by several factors such as the number of records, the number of attributes, the number of records on which model is built, number of bootstraps etc.

Table 1 describes the six different UCI datasets with number of instances that we have used for performance study.

Dataset	No of Instances
Credit-G	1000
Optdigits	5620
Weather	13918

Ecoli	20502
Adult	32561
Wisconsin	65156

**Table 1. Summary of datasets**

Table 2 describes the comparison between Bagging and MCS with C 4.5 as a base classifier. We can see that the accuracy is incremented in case of MCS.

Dataset	Bagging with C4.5 (%)	MCS
Credit-G	74.05	82.05
Optdigits	93.92	94.56
Weather	90.57	91.20
Ecoli	87.93	88.10
Adult	79.21	82.27
Wisconsin	95.04	95.10

**Table 2. Accuracy performance (Bagging Vs MCM)**

We have also compared Bagging and MSC with all the datasets using REPTree and Decision Stumps as base classifiers. In all the comparison we got improved results in MSC then in Bagging.

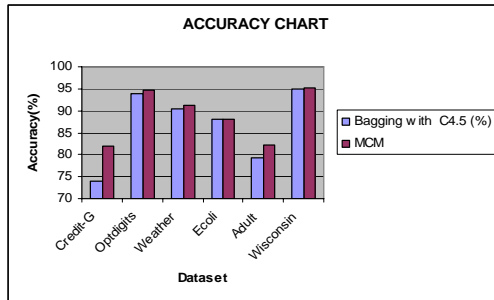

**Figure 3. Comparison of Bagging and MCS (Multiple Classifier System) using WEKA tool. The x-coordinates shows different datasets, y-coordinates shows accuracy in percentage.**

So, we can say that because of the instability of the base classifier, Bagging may fail to improve performance of base classifier, also bagging may work deterioratically in some large benchmark datasets as well. In that situation MCS may help to improve that.

## 9. CONCLUSION

This paper comprehensively shows the comparison between MCS algorithm and Bagging using C4.5 as a base classifier. Due to the instability of the base classifiers (i.e. Decision Tree C4.5), there is no guarantee that bagging will improve the performance of the base classifier every time. MCS eliminates the limitations of Bagging on benchmark datasets and improves the accuracy.

## 10. REFERENCES

- [1] BREIMAN, L., "Bagging Predictors", Technical Report 421, Department of Statistics, University of California, Berkeley.1994
- [2] David Opitz, Richard Maclin (1999). "Popular Ensemble Methods: An Empirical Study". Journal of Artificial Intelligence Research 11 (1999) 169-198.
- [3] ROBI POLIKAR, "Ensemble based system in decision making", IEEE Circuits and system magazine, Third Quarter, 2006.
- [4] Nikunj C. Oza, (2004). "Ensemble Data Mining Methods".
- [5] FAISAL ZAMAN, "A Robust Method Using Median as a Combination Rule", IEEE 8<sup>th</sup> international conference, DOI 10.1109, IT workshop 56,
- [6] J. R. Quinlan, (2006). "Bagging, Boosting, and C4.5".
- [7] KRISTINANA MACHOVA, FRANTISEK BARCAV, PETER BENDAR, "A bagging method using Decision Tree in the role of base classifiers", technical University, Letna, 2006
- [8] GIORGIO FUMERA, Member, "A theoretical analysis of bagging as a linear combination of classifiers", IEEE, and Alessandra Serrau,2008
- [9] Machine learning UCI dataset repository <http://www.ics.uci.edu/mllearn/MLRepository.html>



# EMISSION SCENARIO AT ROAD INTERSECTIONS : A CASE STUDY OF SURAT CITY

Asst.Prof Jayesh A. Shah, Principal Dr. F.S.Umrigar, Ast.Prof Dr L.B.Zala, Ast.Prof Neeraj D.Sharma  
V.B.T.Engg.College , Umrah  
B.V.M Engg. College , V.Vidyanagar

***ABSTRACT:-Indian urban areas are experiencing drastic growth in vehicular population due to most classical reasons of speedy industrialization and urbanization growth . Upshots of such growth are delay and increase traffic congestion on roads, up surging of travel time and fatal accidents and beyond all these the most objectionable issue of increasing pollution levels in urban bases. This paper is an attempt to focus on the pollution level on some of the significant intersections of Surat city in Gujarat.***

## INTRODUCTION

The tremendous increase in mobilization of human society has resulted in phenomenal rise in vehicular traffic on the major roadways. The vehicles discharge an appreciable amount of exhaust emission, which consist of poisonous gases like carbon monoxide, sulphur dioxide, oxides of nitrogen etc. The emission from the vehicles cause adverse effects on plants ,human beings, animals, soil and other environmental components, However every urban area dominance some significant points, regions, stretches of traffic with heavy air pollution and the road intersections are the most critical locations in urban region ,where air pollution is at predominant stage. Presently world survey points out that many developed urban regions are under the influence of air pollution due to vehicular population and many of them have reported the major level of such emission at traffic road intersections due to one or another reasons which may be due to improper practice

of maintaining vehicles , improper operation , old age vehicles , unrealistic design of road intersections or lacking or signalized intersection etc. ,Among these

many cities , megacities , towns of India are facing nastiest scenario at various temporal stages during the year.

The present study is carried out at Surat city which is considered as one of the most developed city of Gujarat state in India. However due to fast development and expansion of city Surat is also experiencing the classical issues of urban transportation like traffic congestion , traffic delay and the most crucial issue of urban air pollution. Here efforts are carried out to recognize most air pollution stimulating traffic intersections in the city and traffic volume surveys alongwith mission survey for CO and HC pollutants have been conducted at some of such intersections during some peak duration.

## MATERIAL AND METHODS

Primarily on the base of present scenario of city traffic as well data of RTO-Surat & Surat Municipal Corporation (SMC) city area is classified on the base of primary and secondary traffic intersections where air pollution fluctuates, however during such classification it is taken care that same categories of intersections are grouped in same group .(*This identification of road intersections includes only intense pollution prone intersections, so not all intersections of city are included and it is also to be noted that survey work is carried out only at some of the following intersections till, remaining is under progress-Some more intersections may be identified at later stage of survey*). Such categories of road intersections are defined on the base of traffic density, use of such intersections during day and night, average pollution level ,traffic delay on such intersection etc. According to this two categories of road intersections , i.e primary and secondary are designated under this survey.(List of existing intersections under these categories are listed in Table-1 ).Mixed traffic conditions were observed during survey work at peak and slack timings.

**Table-1 Identified Primary Intersections**

<b>Sr No</b>	<b>Name of Intersection</b>	<b>Assigned Id</b>	<b>Type of Intersection</b>	<b>Name of Road</b>
1	Gujarat Gas Circle	P1	Four arm Signalized roundabout	Hazira Road
2	Palanpur Patia	P2	T-Type signalized	Rander Road
3	Sona Restaurant	P3	Four arm signalized	Rander Road
4	Navyug College	P4	Four arm staggered signalized	Rander Road
5	Sargam Shoping Centre	P5	Four arm staggered Signalized	Dumas Road
6	Chopati	P6	T-Type signalized	Dumas Road
7	Athwagate flyover bridge	P7	Four arm staggered signalized	Dumas Road-Ring Road
8	Majura Gate Circle	P8	Four arm staggered signalized	Ring Road
9	Chowk Circle	P9	Four arm signalized	Stn Road
10	Sahara Darwaja	P10	T-Type staggered signalized	Ring Road
11	Delhi Gate	P11	Four arm signalized	Stn Road

**Table-2 Identified Secondary Intersections**

<b>Sr No</b>	<b>Name of Intersection</b>	<b>Assigned Id</b>	<b>Type of Intersection</b>	<b>Name of Road</b>
1	Choksi wadi	S1	T-Type signalized	Kadvapatidarwadi Arterial Road
2	Bhulka Bhavan	S2	T-Type signalized	Hazira Road
3	Rishabh Circle	S3	Four arm signalized	Rander Road
5	Bhagal Circle	S4	Four arm Signalized	Stn Road

### Sample Collection & Analysis

Among all identified intersections survey was carried out at two primary intersections (Chowk Circle and Gujarat Gas Circle) where parameters of CO and HC were measured with CO-HC Analyzer PEA 205-Indus auto exhaust monitor gas analyzer from vehicles under idling engine conditions. Both these gases are detected by Non dispersive infrared(NDIR) method. The instrument measure CO in percentage and HC in ppm in the stream of exhaust gas. The analyzer uses the principle of non dispersive infrared technique for measurement. By the consideration of study point of view random sampling was carried out from the fleet of the traffic

flow ,however Surat Traffic police supported during such survey. 1000 Nos. of 2 -Wheelers ,500 Nos. of 3-Wheelers Petrol vehicles samples selected for survey work. Age of vehicle has been considered as significant variable for the analysis part.

### RESULTS AND DISCUSSION

Average emission levels of CO and HC using CO-HC analyzer at both the intersections are tabulated in Table 2 and its graphical presentation is shown in Figure-1

**Table 2: Average CO and HC Emission**

Vehicles	Age (years)	Type of Engine/Ignition	Samples Taken for Survey	Average Emission	
				CO (%)	HC(ppm)
3-Wheelers	More than 10	2 Stroke	90	3.9	6750
3-Wheelers	More than 10	4 stroke	10	3.48	5875
2-Wheelers	More than 10	2 Stroke	100	3.55	6680
2-Wheelers	More than 10	4 stroke	150	3.22	4672
3-Wheelers	Less than 10	2 Stroke	250	3.12	4880
3-Wheelers	Less than 10	4 stroke	150	2.88	3660
2-Wheelers	Less than 10	2 Stroke	350	2.90	4518
2-Wheelers	Less than 10	4 stroke	400	2.32	3050

**\* Combined includes two and four stroke engine for 2 Wheelers**

Above results at two selected intersections indicates that comparatively 3-Wheelers contributes more concentration of Carbon Monoxide and Hydrocarbons to the environment and also the contribution of such parameters are more from 2 Stroke vehicles than 4 Stroke Vehicles.

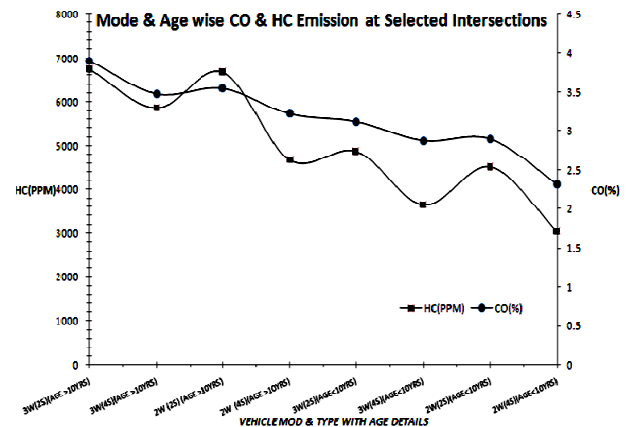

**Figure-1 Chart Representing the CO & HC Emission scenario at Selected Intersections of Surat City**

## FUTURE WORK

Above scenario represents the need of detail survey at another intersections and model study of vehicular exhaust emission, However such thing can be carried out with conventional way of stastical modeling approach but with the modern trend of research has now opened the research prospects with geospatial base where numerous factors can be considered simultaneously for modeling analysis of pollutant emission at respective geo referenced locations. GIS and GPS are the best modeling tools and analytical approach for this. Multi decision making can also be incorporate with the introduction of GIS and GPS study of identified intersections. So in such regard these two and other road intersections are planned to map with GPS and configured with GIS for detailed analysis of pollutant behaviour at typical intersection and it can be easily verified by implementing the model at same type and same traffic patterned intersection.

## CONCLUSION

As from the obtained results it appears that Old aged vehicles are prone to cause much emission of CO and HC than the new i.e (having the age less than 10 years) and also 2 Strokes vehicles are found with more concentration of CO and HC than 4 Stroke. It is interested to note that despite of same type vehicles(i.e-2 stroke or 4-stroke) emission was found different due to vehicular age factor, adulteration of fuel, etc. Such factors should be analyzed simultaneously to get more concrete outcome of the modeling study to be carried out at said intersection. However in present case study survey was preliminary level survey but detail survey with more parameters and by incorporating seasonal variations is required to create geospatial model for the air pollution study at these and other remaining primary and secondary road intersections.

## REFERENCES

1. Bandopadhyay S.N., "Automobile Air Pollution and its control, Indian Highways, 1996
2. Dr. Satu Kush, "Automobile Pollution", 1<sup>st</sup> ed., IVY Publishing House, Delhi, 2001.
3. Hayashi & Roy(1995),"Transport Land use and Environment" Kluwer, Boston
4. Rao C.S(2001), " Environmental Pollution Control Engineering", New Age International Pvt. Ltd., New Delhi
5. S.Vijay Kumar,"Traffic and transport impact on Environment-An Overview",Feb-1997
6. Sharma N.D (2003),,"Vehicular Pollution Growth:- A Trend of Surat City", *Proc., Urban Air Pollution :Issues & Management* ,National Conference at SVNIT –Surat ,pp-2-76
7. Tailor R.(2002),,"Metropolitan Travel Behaviour Analysis: A Case study of Surat City". *MTRP Dissertation*, SVNIT, Surat
8. Umrigar F.S., (2003)"Urban Transport Plan-Let us Move Urbanities-Not Automobiles:", *Journal of Engineering & Technology, Sardar Patel University*, Vol-16-pp-II-III

# Performance Comparison of Space Time Codes

Anshu Shah, Asst Prof. Gandhinagar Institute of Technology, Gandhinagar  
M. Salim, Asst Prof, MNIT, Jaipur  
Prof. R.P. Yadav, MNIT, Jaipur

**Abstract:** Space-time coding is a technique used in wireless communications to transmit multiple copies of a data stream across a number of antennas and to exploit the various received versions of the data to improve the reliability of data-transfer. The fact that transmitted data must traverse a potentially difficult environment with scattering, reflection, refraction and so on as well as be corrupted by thermal noise in the receiver means that some of the received copies of the data will be 'better' than others. This redundancy results in a higher chance of being able to use one or more of the received copies of the data to correctly decode the received signal. In fact, space-time coding combines all the copies of the received signal in an optimal way to extract as much information from each of them as possible. This paper presents performance evaluation of concatenated Space Time code in Rayleigh Fading environment. This code uses Space Time Trellis Code as Outer code and space Time Block Code as inner code. Hence providing advantage of diversity of STBC along with STTC's decoding advantage

## Section-1

### Space Time Block Codes: Introduction

In the case of STBC in particular, the data stream to be transmitted is encoded in blocks, which are distributed among spaced antennas and across time. While it is necessary to have multiple transmit antennas, it is not necessary to have multiple receive antennas, although to do so improves performance [1]. This process of receiving diverse copies of the data is known as diversity reception and is what was largely studied until Foschini's 1998 paper.

An STBC is usually represented by a matrix. Each row represents a time slot and each column represents one antenna's transmissions over time.

#### A. Alamouti scheme with two transmitter one receiver [2]

The scheme uses two transmit antennas and one receive antenna and may be defined by the following three functions:

- The encoding and transmission sequence of information symbols at the transmitter;
- The combining scheme at the receiver;
- The decision rule for maximum likelihood detection.

**1) The Encoding and Transmission Sequence:** At a given symbol period, two signals are simultaneously transmitted from the two antennas. The signal transmitted from antenna zero is denoted by  $s_0$  and from antenna one by  $s_1$ . During the next symbol period signal  $(-s_1^*)$  is transmitted from antenna zero, and signal  $s_0^*$  is transmitted from antenna one where  $*$  is the complex conjugate operation. This sequence is shown in Table I.

	TX ant0	TX ant1
Time t	$s_0$	$s_1$
Time t+T	$-s_1^*$	$s_0^*$

**Table 1: the notation for the transmitted signals at the two transmit antennas**

Here encodings is done in space and time. The channel at a time t is modeled by a complex multiplicative distortion  $h_0(t)$  for transmit antenna 1 and  $h_1(t)$  for transmit antenna 2. We assume that the fading is constant across 2 consecutive symbols .

$$h_0(t) = h_0(t + T) = \alpha_0 e^{j\theta} ; h_1(t) = h_1(t + T) = \alpha_1 e^{j\theta} \quad (1)$$

where T is the symbol duration. The Receiver symbols can now be expressed as

$$r_0(t) = r_0(t + T) = h_0 s_0 + h_1 s_1 + n_0$$

$$r_1(t) = r_1(t + T) = -h_0 s_1^* + h_1 s_0^* + n_1 \quad (2)$$

Where  $r_0$  and  $r_1$  are received signals at a time t and t+T and  $n_0$  and  $n_1$  are complex random variable representing receiver noise and interference. Received signal  $r_0$  consist of signals  $s_0$  and  $s_1$  and received signal  $r_1$  consist of the conjugate  $s_1^*$  and  $s_0^*$ . To determine the transmitted signals, we have to uncouple the 2 equations and extract out measures of the transmitted signals from these equations. This is done in the combiner the combiner is associated by the channel estimator which provides perfect estimation of the channel parameters.

The main advantages of the Alamouti scheme is that simple signal processing is performed to separate the signals  $s_0$  and  $s_1$  respectively the estimates of the transmitted signals are formed as

$$\tilde{s}_0 = h_0^* r_0 + h_1 r_1^*$$

$$\tilde{s}_1 = h_1^* r_0 - h_0 r_1^* \quad (3)$$

so after solving the equations results obtained

$$\begin{aligned} s_0 \sim & (\alpha_0^2 + \alpha_1^2) s_0 + h_0^* n_0 + h_1 n_1^* \\ s_1 \sim & (\alpha_0^2 + \alpha_1^2) s_1 - h_0 n_1^* + h_1^* n_0 \end{aligned} \quad (4)$$

The maximum likelihood decoder must now yield the symbols transmitted over two symbol interval. For the case of PSK the decision rule can be simplified to,

Decide in the favor of signal point  $s_i$  if

$$d^2(s_0 \sim, s_i) \leq d^2(s_0 \sim, s_k) \quad \text{such that } i \neq k.$$

A similar rule can be stated for receiver estimate  $s_i \sim$  also

Decide in the favor of signal point  $s_j$  if

$$d^2(s_1 \sim, s_j) \leq d^2(s_1 \sim, s_k) \quad \text{such that } j \neq k$$

if the similar signal is received by two antennas then the decoder equation will be:

$$s_0 \sim = h_0^* r_0 + h_1 r_1^* + h_2^* r_2 + h_3 r_3^*$$

$$\Rightarrow s_0 \sim = (\alpha_0^2 + \alpha_1^2 + \alpha_2^2 + \alpha_3^2) s_0 + h_0^* n_0 + h_1 n_1^* + h_2^* n_2 + h_3^* n_3$$

$$s_1 \sim = h_1^* r_0 - h_0 r_1^* - h_2^* r_3 + h_3 r_2^*$$

$$s_1 \sim = (\alpha_0^2 + \alpha_1^2 + \alpha_2^2 + \alpha_3^2) s_1 + h_1^* n_0 - h_0 n_1^* + h_3^* n_2 - h_2 n_3^*$$

**Table 2- the definition of channels between the transmit and receive antennas**

	RX ant0	Rx ant 1
TX ant 0	$h_0$	$h_2$
TX ant 1	$h_1$	$h_3$

And

**Table 3 -the notation for the received signals at the two receive antennas**

	RX ant0	Rx ant 1
Time t	$r_0$	$r_2$
Time T+t	$r_1$	$r_3$

	TX ant0	TX ant1
Time t	$s_0$	$s_1$
Time t+T	$-s_1^*$	$s_0^*$

The recovered signal are then applied to ML detector, which works in he similar fashion stated above.

### Higher order STBCs

Tarokh et al. discovered a set of STBCs [3][4] that are particularly straightforward, and coined the scheme's name. They also proved that no code for more than 2 transmit antennas could achieve full-rate. Their codes have since been improved upon (both by the original authors and by many others). Nevertheless, they serve as clear examples of why the rate cannot reach 1, and what other problems must be solved to produce 'good' STBCs. They also demonstrated the simple, linear decoding scheme that goes with their codes under perfect channel state information assumption.

$$C_{3,1/2} = \begin{bmatrix} s_1 & s_2 & s_3 \\ -s_2 & s_1 & s_4 \\ -s_3 & s_4 & s_1 \\ -s_4 & -s_3 & s_2 \\ s_1^* & s_2^* & s_3^* \\ -s_2^* & s_1^* & s_4^* \\ -s_3^* & s_4^* & s_1^* \\ -s_4^* & -s_3^* & s_2^* \end{bmatrix} \quad \text{and} \quad C_{3,3/4} = \begin{bmatrix} s_1 & s_2 & \frac{s_3}{\sqrt{2}} \\ -s_2^* & s_1^* & \frac{s_4}{\sqrt{2}} \\ \frac{s_3^*}{\sqrt{2}} & \frac{s_4^*}{\sqrt{2}} & \frac{(-s_1 - s_1^* + s_2 - s_2^*)}{2} \\ \frac{s_3^*}{\sqrt{2}} & -\frac{s_4^*}{\sqrt{2}} & \frac{(s_2 + s_2^* + s_1 - s_1^*)}{2} \end{bmatrix}$$

$$C_{4,1/2} = \begin{bmatrix} s_1 & s_2 & s_3 & s_4 \\ -s_2 & s_1 & s_4 & s_3 \\ -s_3 & s_4 & s_1 & -s_2 \\ -s_4 & -s_3 & s_2 & s_1 \\ s_1^* & s_2^* & s_3^* & s_4^* \\ -s_2^* & s_1^* & s_4^* & s_3^* \\ -s_3^* & s_4^* & s_1^* & -s_2^* \\ -s_4^* & -s_3^* & s_2^* & s_1^* \end{bmatrix} \quad \text{and} \quad C_{4,3/4} = \begin{bmatrix} s_1 & s_2 & \frac{s_3}{\sqrt{2}} & \frac{s_4}{\sqrt{2}} \\ -s_2^* & s_1^* & \frac{s_4}{\sqrt{2}} & -\frac{s_3}{\sqrt{2}} \\ \frac{s_3^*}{\sqrt{2}} & \frac{s_4^*}{\sqrt{2}} & \frac{(-s_1 - s_1^* + s_2 - s_2^*)}{2} & \frac{(-s_2 - s_2^* + s_1 - s_1^*)}{2} \\ \frac{s_3^*}{\sqrt{2}} & -\frac{s_4^*}{\sqrt{2}} & \frac{(s_2 + s_2^* + s_1 - s_1^*)}{2} & -\frac{(s_1 + s_1^* + s_2 - s_2^*)}{2} \end{bmatrix}$$

### Simulation Results:

#### Assumptions:

1. Receiver has Perfect Knowledge of channel.
2. Channel is assumed to be Rayleigh with zero mean and unity variance.
3. Frame size is taken as 8 bits.

Under the aforementioned assumptions simulation is done using MATLAB. The simulation results are shown below for Alamouti scheme applied on the following and the results are also shown for them respectively:

1. 2 transmitter and 1 receiver system using BPSK constellation
2. 2 transmitter and 2 receiver scheme using BPSK constellation
3. 2 Transmitter and 2 receiver scheme using QPSK constellation.

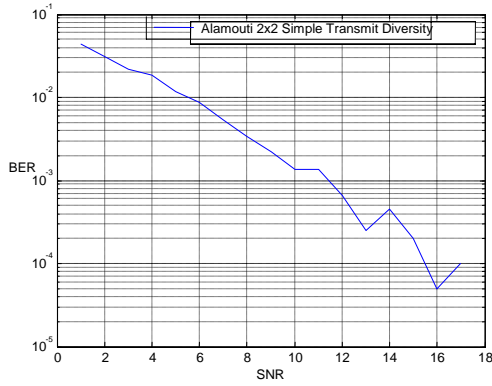

Fig 1: 2 transmitter and 1 receiver system using BPSK constellation

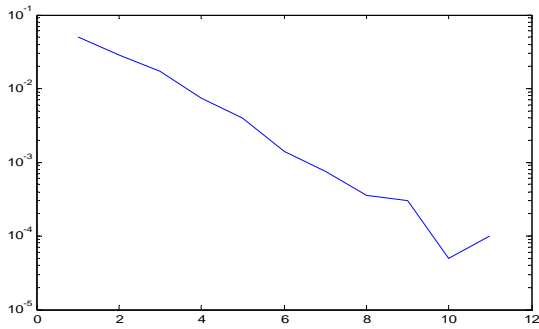

Fig 2: 2 transmitter and 2 receiver scheme using BPSK constellation

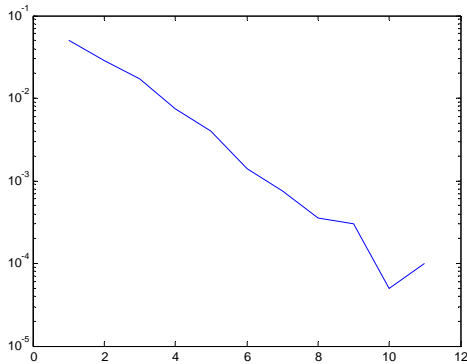

Fig.3: 2 Transmitter and 2 receiver scheme using QPSK constellation

It can be seen from the BER characteristics that with the Alamouti Scheme good error performance can be achieved at lower SNR. The BER performance is independent of modulation used so using this scheme even a lower complexity modulation system can perform better. Improvement in Performance can be achieved using diversity. i.e. the system performance can be increased significantly by increasing the number of transmitting and receiving antennas.

## Section II

### 1) Space Time Trellis Codes: Introduction

Space-Time Coding (STC) is an open loop transmission scheme that was introduced by V. Tarokh[5]. In STC, joint design of channel coding and modulation is done to create efficient transmission techniques which improve system performance by providing both the diversity advantage of multiple transmit antennas and coding gain. In [5], space-time codes based on trellis-coded modulation (TCM) are presented. These codes are called Space-Time Trellis Codes (STTC) and their performance was shown to be very good in slow Rayleigh fading environments. The receiver for these STTC schemes uses Maximum Likelihood Sequence Estimation (MLSE) and the decoding complexity for these schemes (measured in terms of number of trellis states) increases exponentially with transmission rate for a fixed number of transmit antennas.

Space-time trellis codes (STTC) are a type of space-time code used in multiple-antenna wireless communications. This scheme transmits multiple, redundant copies of a trellis (or convolutional) code distributed over time and a number of antennas ('space'). These multiple, 'diverse' copies of the data are used by the receiver to attempt to reconstruct the actual transmitted data. For a STC to be used, there must necessarily be multiple *transmit* antennas, but only a single *receive* antennas is required; nevertheless multiple receive antennas are often used since the performance of the system is improved by so doing.

In contrast to space-time block codes (STBCs), they are able to provide both coding gain and diversity gain and have a better bit-error rate performance. However, being based on trellis codes, they are more complex than STBCs to encode and decode; they rely on a Viterbi decoder at the receiver where STBCs need only linear processing [5].

Space-Time block codes can achieve a maximum possible diversity advantage with a simple decoding algorithm. It is very attractive because of its simplicity. However, no coding gain can be provided by space-time block codes, while non-full rate space-time block codes can introduce bandwidth expansion[7]. STTC was first introduced by Tarokh, Seshadri and Calderbank [4]. It was widely discussed and explored in the literature as STTC can simultaneously offer a substantial coding gain, spectral efficiency, and diversity improvement on flat fading channels.

### B. Encoder Structure for STTC

For space-time trellis codes, the encoder maps binary data to modulation symbols, where the mapping function is described by a trellis diagram. Let us consider an encoder of space-time trellis coded M-PSK modulation with  $n_T$  transmit antennas as shown in Fig.1[6].

The input message stream, denoted by  $c$ , is given by[6]

$$c = (c_0, c_1, c_2, \dots, c_t) \quad (3.1)$$

where  $c_t$  is a group of  $m = \log_2 M$  information bits at time  $t$  and given by

$$c_t = (c_t^1, c_t^2, \dots, c_t^m)$$

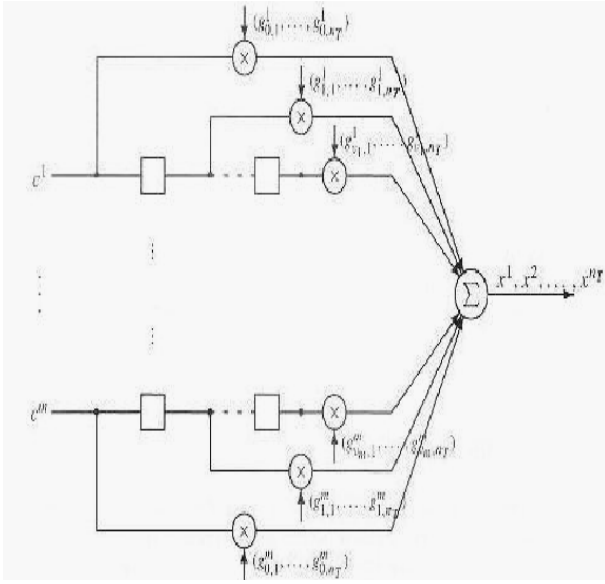

Fig. 4. Encoder for STTC

The encoder maps the input sequence into an M-PSK modulated signal sequence, which

is given by

$$x = (x_0, x_1, \dots, x_t, \dots) \quad (5)$$

where  $x_t$  is a space-time symbol at time  $t$  and given by

$$x_t = (x_t^1, x_t^2, \dots, x_t^{n_T})^T \quad (6)$$

The modulated signals,  $x_t = (x_t^1, x_t^2, \dots, x_t^{n_T})^T$ , are transmitted simultaneously through  $n_T$  transmit antennas.

## Generator Description

In the STTC encoder as shown in Fig.1,  $m$  binary input sequences  $c^1, c^2, \dots, c^m$  are fed into the encoder, which consist of  $m$  feed-forward shift registers. The  $k$ -th input sequence  $c^k = (c_0^k, c_1^k, \dots, c_t^k, \dots)$ , is passed to the  $k$ -th shift register and multiplied by an encoder coefficient set. The multiplier outputs from all shift registers are added modulo  $M$ , giving the encoder output  $x_t = (x_t^1, x_t^2, \dots, x_t^{n_T})^T$ . The connections between the shift register elements and the modulo  $M$  adder can be described by the following  $m$

multiplication coefficient set sequences

$$\begin{aligned} g^1 &= [(g_{0,1}^1, g_{0,2}^1, \dots, g_{0,n_T}^1), (g_{1,1}^1, g_{1,2}^1, \dots, g_{1,n_T}^1), \dots, (g_{t,1}^1, g_{t,2}^1, \dots, g_{t,n_T}^1)] \\ g^2 &= [(g_{0,1}^2, g_{0,2}^2, \dots, g_{0,n_T}^2), (g_{1,1}^2, g_{1,2}^2, \dots, g_{1,n_T}^2), \dots, (g_{t,1}^2, g_{t,2}^2, \dots, g_{t,n_T}^2)] \\ &\dots \\ g^m &= [(g_{0,1}^m, g_{0,2}^m, \dots, g_{0,n_T}^m), (g_{1,1}^m, g_{1,2}^m, \dots, g_{1,n_T}^m), \dots, (g_{t,1}^m, g_{t,2}^m, \dots, g_{t,n_T}^m)] \end{aligned} \quad (7)$$

where  $g_{j,i}^k, k = 1, 2, \dots, m, j = 1, 2, \dots, v_k, i = 1, 2, \dots, n_T$  is an element of the M-PSK constellation set, and  $v_k$  is the memory order of the  $k$ -th shift register.

The encoder output at time  $t$  for transmit antenna  $i$ , denoted by  $x_t^i$ , can be computed as

$$x_t^i = \sum_{k=1}^m \sum_{j=0}^{v_k} g_{j,i}^k c_{t-j}^k \text{ mod } M, \quad i = 1, 2, \dots, n_T \quad (8)$$

These outputs are elements of an M-PSK signal set. Modulated signals from the space time symbol transmitted as time  $t$

$$x_t = (x_t^1, x_t^2, \dots, x_t^{n_T})^T \quad (9)$$

The space-time trellis coded M-PSK can achieve a bandwidth efficiency of  $m$  bits/s/Hz.

The total memory order of the encoder, denoted by  $v_k$ , is given by

$$v = \sum_{k=1}^m v_k \quad (10)$$



Where  $\nu_k$ , is the memory order for the  $k$ -th encoder branch. The value of  $\nu_k$  for M-PSK constellations is determined by

$$\nu_k = \lceil \nu + k - 1 / \log_2 M \rceil \quad (11)$$

The total number of states for the trellis encoder is  $2^\nu$ . The  $m$  multiplication coefficient set sequences are also called the *generator sequences*, since they can fully describe the encoder structure.

### Decoding

For STTC, the decoder employs the Viterbi algorithm to perform maximum likelihood decoding. Assuming that perfect CSI is available at the receiver, for a branch labeled by  $x_t = (x_t^1, x_t^2, \dots, x_t^{n_r})^T$ , the branch metric is computed as the squared Euclidean distance between the hypothesized received symbols and the actual received signals as

$$\sum_{j=1}^{n_r} |r_t^j - \sum_{i=1}^{n_r} h_{j,i}^t x_t^i|^2$$

The Viterbi algorithm selects the path with the minimum path metric as the decoded sequence.

### Simulation Results:

Assumptions:

1. The generator sequences of a 4-state space-time trellis coded QPSK scheme with 2 transmit antennas are assumed to be:  $g_1=[0 \ 2 \ ; \ 2 \ 0]$  and  $g_2=[0 \ 1 \ ; \ 1 \ 0]$
2. The encoder takes  $m=2$  bits as its input at each time.
3. The trellis consists of  $2^\nu=4$  states, represented by state nodes.
4. The Channel is assumed to be Rayleigh.
5. The channel is known perfectly at the receiver.

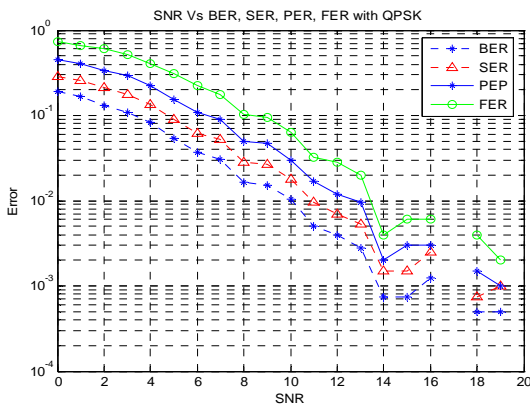

Fig 5: 4-state space-time trellis coded QPSK scheme

From the fig. 5, We can say that Space Time Trellis codes provide improved error performance for wireless systems using multiple antenna. These codes can also provide the full diversity gain as well as coding gain. Performance can be improved by increasing the number of receive antennas but at the cost of increased decoder complexity. Another way to improve performance is either to increase constellation size or opt for higher state STTC.

### Section III

#### Concatenated Space Time Code: Introduction

Concatenation is also frequently employed in space time coded systems. In this case, the outer code is frequently a TCM system whose symbol are transmitted via an inner space time coded system [9][8].

In what follows, we combine space-time block codes with a trellis code to come up with a new structure that guarantees the full diversity with increased rate. Also, we show how to design the trellis code to maximize the coding gain. The result is a systematic method to design space-time trellis codes for any given rate and number of states.

#### The System Model:

The system can be described by the block diagram shown below. Space Time Trellis code is used as outer cod and Space Time Block Codes are used as inner code. The data modulator used in the work is QPSK modulator & channel is assumed to be Rayleigh.

If  $x(t)$  represents the input bit stream &  $s(t)$  is the STTC encoded data, we can model the system as:

$$s(t) = \mathfrak{F}\{x(t)\}_{STTC} \dots \text{i.e. STTC encoding}$$

Here, 4 State STTC is considered and the generator used is the same as was used in STTC encoding.

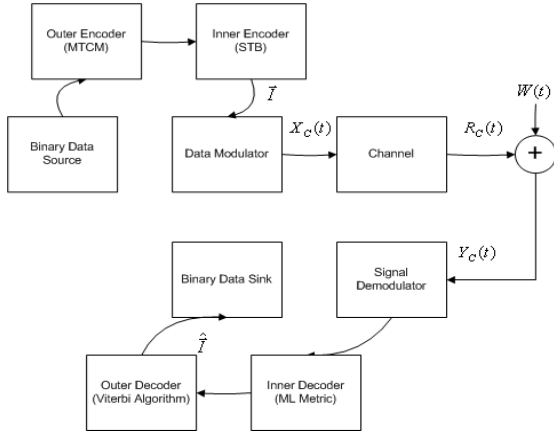

Fig. 6. Proposed system for concatenated encoder and decoder.

$$\tilde{I} = \mathfrak{Z}\{s(t)\}_{STBC} \dots\dots\dots \text{i.e. STBC encoding}$$

The signal  $X_c(t)$  is the 2 bit QPSK modulated signal  $\tilde{I}$ . The QPSK signal may assign any of the four values possible i.e.  $1+i$ ,  $1-i$ ,  $-1+i$  and  $-1-i$ .

The system equation is then written as :

$$Y_c(t) = R_c(t) * X_c(t) + W(t) \quad (12)$$

$Y_c(t)$  &  $W(t)$  are channel response and channel noise(Rayleigh).

**Design of Concatenated code:**

After defining a system, the next problem is how to implement (Alamouti) on encoded STTC codes. For that purpose again consider the STTC encoder. For convenience it is shown below:

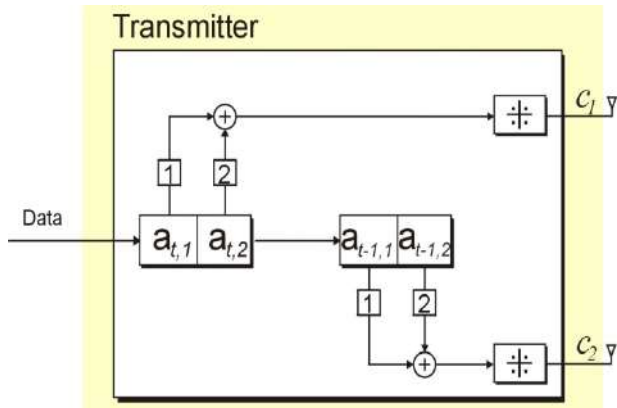

Fig. 7: Encoder for space time trellis code

**Implementation of STBC on encoded STTC:**

In this work, following orthogonal design is used as transmission matrices:

$$C(x_1, x_2) = \begin{pmatrix} x_1 & x_2 \\ -x_2^* & x_1^* \end{pmatrix} \quad (13)$$

Where \* denotes the conjugate operation.

Let the output of the STT encoder  $c_1$  and  $c_2$  are represented as:

$$c_1 = c_t = c_t^1 c_t^2 c_t^3 \dots\dots\dots c_t^n$$

And

$$c_2 = c_{t-1} = c_{t-1}^1 c_{t-1}^2 c_{t-1}^3 \dots\dots\dots c_{t-1}^n \quad (14)$$

The data stream can now be encoded according to Alamouti scheme as

$$\tilde{I}(c_1, c_2) = \begin{pmatrix} c_1 & c_2 \\ -c_2^* & c_1^* \end{pmatrix} \quad (15)$$

In this manner without increasing the number of transmitting antennas significant improvement in the performance can be achieved.

**Decoding:**

Decoder structure for the concatenated code is similar to that used previously for STTC and STBC decoders. Let the received signals at the two receive antennas are  $r_1$  and  $r_2$ , the data can be recovered by applying it first to the STBC decoder and extracting the signals  $c_1$  and  $c_2$  as follows:

$$\begin{aligned} c_1 &= h_0^* r_0 + h_1 r_1^* + h_2^* r_2 + h_3 r_3^* \\ c_2 &= h_1^* r_0 - h_0 r_1^* - h_2^* r_3 + h_3 r_2^* \end{aligned} \quad (16)$$

The recovered data streams are then applied to the Viterbi decoder for further decoding.

## 15 Simulation Results:

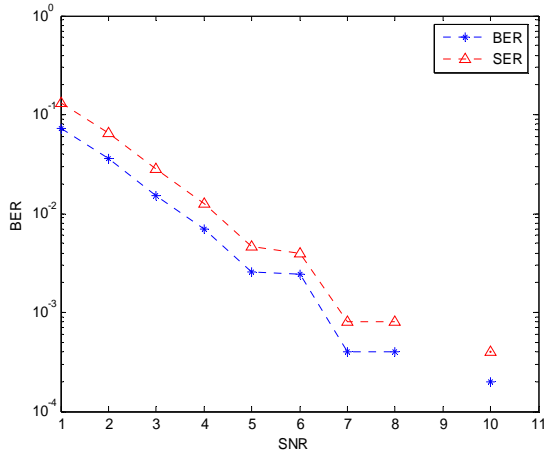

Fig 8: SNR vs BER performance of proposed scheme

For STTC, the decoder employs the Viterbi algorithm to perform maximum likelihood

decoding. Assuming that perfect CSI is available at the receiver, for a branch labeled by

$x_t = (x_t^1, x_t^2, \dots, x_t^{n_T})^T$ , the branch metric is computed as the squared Euclidean distance

between the hypothesized received symbols and the actual received signals as

$$\sum_{j=1}^{n_R} \left| r_t^j - \sum_{i=1}^{n_T} h_{j,i}^t x_t^i \right|^2$$

The Viterbi algorithm selects the path with the minimum path metric as the decoded sequence.

In this work, a simple technique is proposed for designing an improved high-rate space-time code. The proposed design was based on a concatenation of an orthogonal space-time block code and an STTC encoder. A high-rate Concatenated-STTC design was achieved by expanding the cardinality of the space time block code before concatenates it with an outer STTC encoder. Signal orthogonality was exploited to keep decoding complexity of the proposed scheme relatively low.

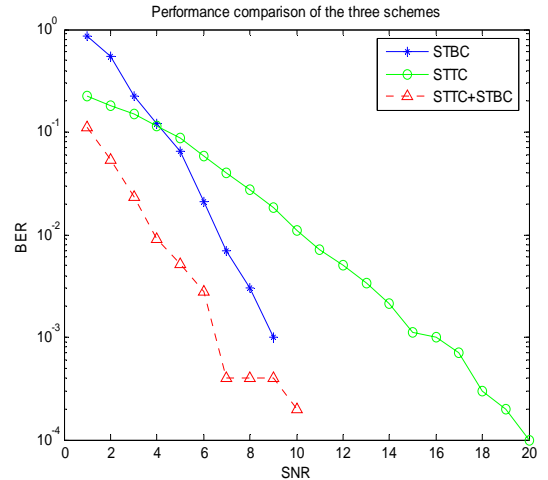

In the above fig. SNR vs. BER performances of three coding techniques using 4 PSK modulation are shown at frame size of 64. We can observe that for an BER of  $10^{-3}$  the required SNR for STBC is 10 dB, for STTC is 17 dB and for concatenated STTC is 7 dB only.

## Section IV

### VII. CONCLUSION

In the thesis work, simulation results are drawn for the three coding schemes namely: Space time Block Codes, Space Time Trellis Codes and Concatenated Space time code where STTC is used as outer code and STBC is used as inner code.

From the simulation results of STBC it can be seen that this code provide performance independent of modulation technique employed. The performance can be further improved by increasing the number of transmit and receive antennas i.e. applying the diversity to this code. The most important point that we can observe is that this code performs with very high efficiency because of orthogonality property under Rayleigh fading environment compared to other codes.

STTC is also simulated and the results are shown in chapter 3 where it has been shown that this code can provide full diversity as well as coding gain. The performance improvement can be achieved by increasing the number of states but it increases receiver complexity. We can also observe that the STTC is sensitive to modulation employed & for getting better performance higher constellation size has to be used [5].

Here, to improve the performance of lower constellation size (we used 4 PSK), Concatenation of STTC with STBC is proposed. The simulation results show that the Concatenated STTC outperforms the two previous methods.

The performance gain that we achieve is at the cost of reduced code rate and increased receiver complexity. If code rate reduction can be tolerated, the proposed scheme shows very good results. Performance can be further improved by increasing the number of transmitting antennas.

*References:*

1. Special Issue on the European Path Toward UMTS, *IEEE Personal Commun. Mag.*, vol. 2, Feb. 1995.
2. Siavash M. Alamouti "A Simple Transmit Diversity Technique for Wireless Communications" *IEEE journal on select areas in communications*, vol. 16, no. 8, october 1998
3. V. Tarokh, H. Jafarkhani, and A.R. Calderbank, "Space time block codes from orthogonal designs", *IEEE Trans. Inform. Theory*, Vol. 45, July 1999.
4. -----," Space time block coding for wireless communication: performance results" *IEEE J. select. Areas commun.* Vol 17, Mar. 1999
5. Vahid Tarokh,, Nambi Seshadri, and A. R. Calderbank, "Space-Time Codes for High Data Rate Wireless Communication: Performance criterion and Code Construction" *IEEE transactions on information theory*, vol. 44, no. 2, march 1998
6. Bahador Amiri "Space-time Trellis codes" thesis.
7. S. Sandhu, R. Heath and Pulraj, " Space time block codes versus space time trellis codes", *ICC* june 2001
8. S. Siwamogsatham and M.P.Fitz, " Improved high rate space time codes via orthogonality and set partitioning",in *proc. IEEE wireless communications and networking conf.* Mar 2002
9. -----, "Improved high rate space time codes via concatenation of expanded orthogonal Block code and M-TCM" in *IEEE ICC* Apr. 2002

# DATA MINING: TERMS AND TECHNIQUES

<sup>1</sup>Mr. Uresh N Parmar, <sup>2</sup>Mr. Krunal G. Patel, <sup>3</sup>Ms. Meenakshi Saroha, <sup>4</sup>Mr. Nishidh S. Chavda

<sup>1,2</sup> Asst. Prof., IT Department, CCET, Wadhwan, Gujarat, India

<sup>3</sup> Lecturer, IT Department, KITRC, Kalol, Gujarat, India

<sup>4</sup> Asst. Prof., CE Department, CIT, Changa, Gujarat, India

ureshparmar13@yahoo.co.in, kgp2003@gmail.com, meenakshi.saroha@gmail.com, nishidhchavda.ce@ecchanga.ac.in

**Abstract:-**Data mining, the extraction of hidden predictive information from large database, is a powerful new technology with great potential to help Companies. Data Mining is the search for the relationships and global patterns that exists in large databases but is 'hidden' among the vast amount of data. Data mining achieves different technical approaches, such as clustering, data summarization, and learning classification rules, finding dependency networks, analyzing and detecting anomalies.

Data mining activities are usually performed by three different classes of users: such as executives, end users and analysts. These users usually perform three types of data mining activity within a corporate environment: episodic, strategic and continuous data mining. Functions available with data mining are classification, clustering, association and many more. It concerned with marketing, insurance, banking and transportation like applications.

Data mining may have problems like uncertainty, missing values, size of the data, data updating and more.

The main objective of this paper is to overcome the brief introduction towards the different terms and next generation techniques of data mining.

## 1. INTRODUCTION

Data mining refers to the Knowledge Discovery in Data bases (KDD). Data mining techniques are identifying nuggets of information or decision making knowledge in bodies of data and extracting these in such a way that they can be put to use classification, prediction, data forecasting and decision making. Data mining is a powerful new technology with great potential to help companies focus on the most important information in their data warehouses.

Data Mining is the search for the relationships and global patterns that exists in large databases but is 'hidden' among the vast amount of data, these relationships represent valuable knowledge about the database and the objects in the database.

Basically data mining is concerned with the analysis of data and the use of software techniques for finding patterns and regularities in sets of data. Data mining analysis process starts with a set of data uses a methodology to develop an optimal representation of the structure of the data during which time knowledge is acquired.

## 1.1 Data mining Architecture

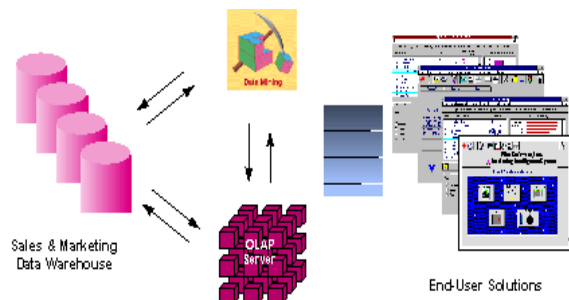

Fig 1. Data mining Architecture

The ideal starting point is a data warehouse containing a combination of internal data tracking all customer contact coupled with external market data about competitor activity. An OLAP (On-Line Analytical Processing) server enables a more sophisticated end-user business model to be applied when navigating the data warehouse [5].

## 2. DATA MINING MODELS

There are two types of model or modes of operation, which may be used to discover information of interest to the user.

### 2.1 Verification Model

The verification model takes input from the user and tests the validity of it against the data. The emphasis is with the user who is responsible for formulating the hypothesis and issuing the query on the data to affirm or negate the hypothesis.

The problem with this model is the fact that no new information is created in the retrieval process but rather the queries will always return records to verify or negate the hypothesis. The user is discovering the facts about the data using a variety of techniques such as queries, multidimensional analysis and visualization to guide the exploration of the data being inspected.

### 2.2 Discovery Model

The discovery model differs in its emphasis in that it is the system automatically discovering important information hidden in the data. The data is sifted in search of frequently occurring patterns, trends and generalizations about the data without intervention or guidance from the user.

### 3. DATA MINING PROCESS

Following are the processes/stages identified in Data Mining and Knowledge Discovery. The phrases depicted start with the raw data and finish with the extracted knowledge, which was acquired as a result of the following stages:

3.1 Data Selection: Examining the entire raw data set identifies the target subset of data and the attributes of interest. This includes selecting or segmenting the data according to some criteria e.g. all those people who own a car, in these way subsets of the data can be determined.

3.2 Data Cleaning: In this step, noise and outliers are removed, field values are transformed to common units and combining existing fields to facilitate analysis creates some new fields. The data is typically put into a relational format, and several tables might be combined in a de normalization step. Also the data is reconfigured to ensure a consistent format as there is a possibility of inconsistent formats because the data is drawn from several sources e.g. sex may recorded as f or m and also as 1 or 0.

3.3 Transformation: The data is not merely transferred across in that overlays may be added such as demographic overlays in the market research. The data is made usable.

3.4 Data mining: This stage is concerned with the extraction of patterns from the data. Data mining algorithms can be applied to extract the interesting patterns of data.

3.4 Interpretation and Visualization: The patterns identified by the system are interpreted into knowledge, which can then be used to support human decision-making e.g. prediction and classification tasks, summarizing the contents of a database or explaining observed phenomena. The patterns are presented to end users in an understandable form, e.g. through visualization[1].

### 4. DATA MINING NEXT GENERATION TECHNIQUES.

Data mining techniques are as follows:

#### 4.1 Cluster Analysis

In an unsupervised learning environment the system has to discover its own classes. We can cluster the data in the database as shown in the Figure 1. The first step is to discover subsets of related objects and then find descriptions e.g. D1, D2, D3 etc., that describe each of these subsets.

**Fig 2. Discovering clusters and descriptions in a database**

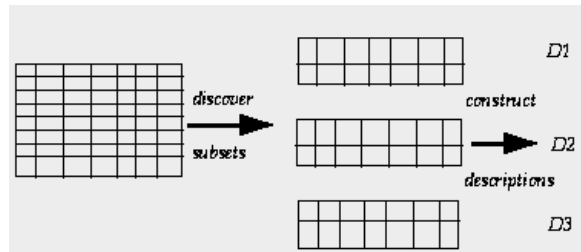

The following is an example of objects that describe the weather at a given time. The objects contain information on the outlook, humidity etc. Some objects are positive examples denote by P and others are negative i.e. N. Classification is in this case the construction of a tree structure, illustrated in the

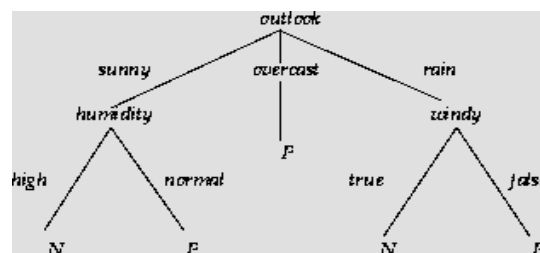

figure 2 which can be used to classify all the objects correctly.

**Fig 3. Decision tree structure**

#### 4.2.2 Rule Induction

A data mine system has to infer a model from the database that is it may define classes such that the database contains one or more attributes that denote the class of a tuple is the predicted attributes while the remaining attributes are the predicting attributes. Class can then be defined by condition on the attributes. When the classes are defined the system should be able to infer the rules that govern classification. Production rules have been widely used to represent knowledge in expert systems and they have the advantage of being easily interpreted by human experts because of their modularity i.e. a single rule can be understood in isolation and doesn't need reference to other rules. The structure of such rules is in the form of if-then rules.

#### 4.2.3 Neural Networks

Neural networks are an approach to computing that involves developing mathematical structures with the ability to learn. Neural networks can derive meaning from complicated or imprecise data and can be used to extract patterns and detect trends that are too complex to be noticed by either humans or other computer techniques. A trained neural network can be thought of as an "expert" in the category of information it has been given to analyze. Neural networks identify patterns or trends in data, they are good for prediction or forecasting. Neural networks use a set of processing elements (or nodes) analogous to neurons in the brain. These processing elements are interconnected in a network that can then identify patterns in data once it is exposed to the data, i.e. the network learns from experience just as people do. This distinguishes neural networks

Clustering and segmentation basically partition the database so that each partition or group is similar according to some criteria. Clustering/segmentation in databases are the processes of separating a data set into components that reflect a consistent pattern of behavior.

#### 4.2 Induction

Induction is the inference technique, which can be used to infer the generalized information from the database. Induction has been used in the following ways within data mining.

##### 4.2.1 Decision trees

Decision trees are simple knowledge representation and they classify examples to a finite number of classes, the nodes are labeled with attribute names, the edges are labeled with possible values for this attribute and the leaves labeled with different classes. Objects are classified by following a path down the tree,

from traditional computing programs that simply follow instructions in a fixed sequential order. The structure of a neural network is shown in the figure 4.

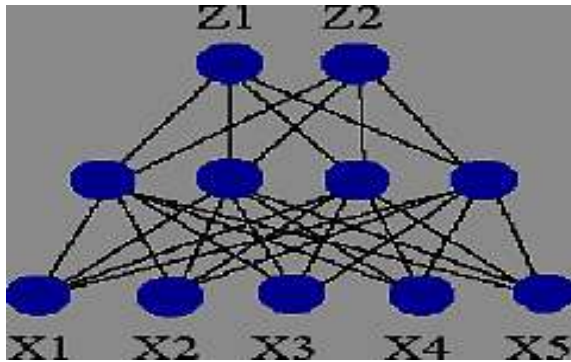

Fig 4. Structure of Neural Network

The bottom layer represents the Input layer, in this case with 5 input labels X1 through X5. The middle layer is called the hidden layer, with a variable number of nodes. The output layer in this case has two nodes, Z1 and Z2 representing output values we are trying to determine from the inputs. Neural networks suffered from long learning times, which become worse as the volume of data grows [2].

#### 4.2.4 Data Visualization

Data visualization makes it possible for the analyst to gain a deeper, more intuitive understanding of the data and can work well for data mining. Data mining allows the analyst to focus on certain patterns and trends and explore in-depth using visualization. The volume of data in a database can overwhelm the data visualization but in conjunction with data mining can help with exploration.

### 5. DATA MINING FUNCTIONS

Data mining methods may be classified by the function they perform or according to the class of application they can be used in. The data mining functions are as follows.

#### 5.1 Classification

The clustering techniques analyze a set of data and generate a set of grouping rules that can be used to classify future data. The mining tool automatically identifies the clusters, by studying the pattern in the training data. Once the clusters are generated, classification can be used to identify, to which particular cluster, input belongs. For example, one may classify diseases and provide the symptoms, which describe each class or subclass [5].

#### 5.2 Association

Given a collection of items and a set of records, each of which contain some number of items from the given collection, an association function is an operation against this set of records which return patterns that exist among the collection of items. These patterns can be expressed by rules such as "72% of all the records that contain items A, B and C also contain items D and E." The specific percentage of occurrences (in this case 72) is called the

confidence factor of the rule. Also, in this rule, A, B and C are said to be on an opposite side of the rule to D and E. Associations can involve any number of items on either side of the rule.

A typical application that can be built using an association function is *Market Basket Analysis*. Thus, by invoking an association function, the market basket analysis application can determine affinities such as "20% of the time that a specific brand toaster is sold, customers also buys a set of kitchen gloves and matching cover sets."

A supervised machine learning task involves constructing a mapping from input data (normally described by several features) to the appropriate outputs. In a classification learning task, each output is one or more classes to which the input belongs. The goal of classification learning is to develop a model that separates the data into the different classes, with the aim of classifying new examples in the future.

Given a new example, the ensemble passes it to each of its multiple base models, obtains their predictions, and then combines them in some appropriate manner (e.g., averaging or voting).

#### 5.3 Sequential/Temporal patterns

Sequential/temporal pattern functions analyze a collection of records over a period of time for example to identify trends. The identity of a customer who made a purchase is known, an analysis can be made of the collection of related records of the same structure. Sequential pattern mining functions can be used to detect the set of customers associated with some frequent buying patterns. For example a set of insurance claims can lead to the identification of frequently occurring sequences of medical procedures applied to patients which can help identify good medical practices as well as detect some medical insurance fraud.

#### 5.4 Clustering and Segmentation

Clustering and segmentation are the processes of creating a partition so that all the members of each set of the partition are similar according to some measure. A cluster is a set of objects grouped together because of their similarity or proximity. When learning is unsupervised then the system has to discover its own classes i.e. the system clusters the data in the database. Using the rules or functions can

Form the cluster.

### 6. DATA MINING ACTIVITIES AND USERS

Data mining activities are usually performed by three different classes of users: executives, end users and analysts.

- *Executives* spend much less time with computers than the other groups.
- *End users* are sales people, market researchers, scientists, engineers, physicians, etc
- *Analysts* may be financial analysts, statisticians, consultants, or database designers.

These users usually perform three types of data mining activity within a corporate environment: *episodic, strategic and continuous data mining*.

In *episodic mining* we look at data from one specific episode such as a specific direct marketing campaign. Analysts usually perform episodic mining. In *strategic mining* we look at larger

sets of corporate data with the intention of gaining an overall understanding of specific measures such as profitability. In *continuous mining* we try to understand how the world has changed within a given time period and try to gain an understanding of the factors that influence change [9].

## 7. DATA MINING APPLICATIONS

Data mining has many and varied fields of application, some of which are listed below.

- *Marketing*: Identify buying patterns from customers & Market basket analysis.
- *Banking*: Detect patterns of fraudulent credit card use & Identify 'loyal' customers.
- *Insurance and Health Care*: Claims analysis, Predict which customers will buy new policies & Identify fraudulent behavior.
- *Transportation*: Determine the distribution schedules & analyze loading patterns [7].

## 8. DATA MINING PROBLEMS

As data mining discovering the hidden knowledge from the available data, it also has some problems describing below:

- *Limited Information*: If some attributes essential to knowledge about the application domain are not present in the data it is impossible to discover significant knowledge about a given domain.
- *Noise and missing values*: Error in either the values of attributes or class information are known as noise. We have to omit the corresponding records of missing data or average over the missing values using Bayesian techniques.
- *Uncertainty*: Uncertainty refers to the severity of the error and the degree of noise in the data.
- *Size, updates, and irrelevant fields*: Databases are large and dynamic & their contents are changing as information is added, modified or removed. So, it is difficult to ensure that the rules are up-to-date and consistent with the most current information.

## 9. CONCLUSION

This paper comprehensively describes various terms and techniques of data mining. Also giving the concepts regarding functions, applications and processes of Data Mining. Data Mining or Knowledge Discovery in Databases (KDD) is the nontrivial extraction of implicit, previously unknown, and useful information from data.

## 10. REFERENCES

- [1] Data mining - concept and techniques Han & Kamber
- [2] DAVID OPITZ, RICHARD MACLIN (1999). "Popular Ensemble Methods: An Empirical Study". Journal of Artificial Intelligence Research 11 (1999) 169-198.
- [3] ROBI POLIKAR, "Ensemble based system in decision making", IEEE Circuits and system magazine, Third Quarter, 2006.
- [4] NIKUNJ C. OZA, (2004). "Ensemble Data Mining Methods".
- [5] U.N.PARMAR, S.J.AGRAVAT, A.K.RANPURA, "Multiple Classifier System using Bagging Method", Jan issue 2010, IJ-ETA-ETS, international journal, Sangli.
- [6] J. R. QUINLAN, (2006). "Bagging, Boosting, and C4.5".
- [7] "Building Data Mining application for CRM" - KURT THEARLING.
- [8] URESH PARMAR, NEHA PARTIWALA, NISHIDH CHAVDA, "QUEST (Quick Unbiased Efficient Statistical Tree): An efficient algorithm of Classification Tree in Data Mining", July issue 2010, IJ-ETA-ETS, international journal, Sangli.
- [9] Data mining - practical machine learning tools and techniques, Witten



# Optimized Rumor Routing Algorithm for Wireless Sensor Networks

Zalak Modi<sup>1</sup>, Sunil jardosh<sup>2</sup>, Sunil jardosh<sup>3</sup>

1.G.H.Patel college of Eng. and Tech., Anand

2.DA-IICT, Gandhinagar

3.DA-IICT, Gandhinagar

zalak\_modi2000@yahoo.com, Email:sunil\_jardosh@daiict.ac.in,Email:prabhat\_ranjan@daiict.ac.in

**Abstract:-** *Wireless Sensor Network is data centric network that works on query reply mechanism with various types of queries. Rumor routing is of the data centric routing algorithm for Wireless Sensor Networks. Literature shows that Rumor routing algorithm is energy efficient than the Ant Colony Optimization, Gossip Routing, Deterministic Flooding and Directed Diffusion. Data centric WSN works has various types of queries that govern the traffic patterns of WSN. In our work we have exploited this key feature of Data centric WSN for improving the energy efficiency of Rumor routing algorithm. Based on information requirement, we have classified queries in two parts, instantaneous queries and continuous queries. Using this query classification we have optimized the Rumor routing for different types of traffic patterns. Our simulation result shows significant reduction in energy consumption after applying our optimization over Rumor Routing algorithm which we called Optimized Rumor Routing.*

## I. INTRODUCTION

In recent years many Network Layer protocols have been designed for routing in Wireless Sensor Networks (WSN). Karaki and Kamal in [9] gave the survey of routing protocols used in WSN. They have classified the routing protocols based on their node deployment strategy (deterministic or probabilistic), data reporting strategy (time driven, event driven, query driven or hybrid) and Energy consumption strategy without losing accuracy. Based on this survey Rumor Routing [1] can be classified as data centric kind of routing algorithm for WSN. Mainly Rumor routing algorithm is used when the geographical location of deployed nodes are unknown. For an example, randomly deployed environment monitoring network or habitat monitoring network uses Rumor routing as Network Layer routing protocol.

In WSN Data collection is divided into two parts query flooding and event flooding. Both the flooding mechanism creates energy overhead in WSN. Recent literature on WSN shows that many proposed schemes try to control query flooding and event flooding to reduce energy overhead of data collection. Rumor routing algorithm is a logical compromise between query flooding and event flooding. Ref. [4] has defined zonal rumor

routing which increases the query delivery rate by introducing zones in WSN. Ant colony algorithm [5] was used to know the behavior of the event agents or query agents, while in directional rumor routing [6] algorithm uses straight line approach instead for the random walk. Zonal rumor routing introduced by [4] shows that rumor routing is an energy efficient algorithm compared to gossip based routing, directed diffusion, Ant Colony Optimization and Deterministic Flooding. The randomized rumor routing algorithm increases the robustness of rumor routing algorithm. As shown above, literature in Rumor routing focuses on the query propagation model but they have not used the knowledge available in the query. In the paper we have used that available query knowledge to increase the efficiency of Rumor routing in data collection. To achieve this we have classified the query according to their need of information. As the traffic in network depends on the type of query generated by the network, use of available knowledge in query reduces the network traffic and gives longer network lifetime. Our proposed approach is complementary to all the suggestions proposed above and helps them further in improving the performance of network.

Rest of the paper is organized as follow. Section 2 covers working of our Query aware rumor routing protocol, section 3 covers algorithm for the different nodes and Section 4 covers our simulation results. We have concluded our paper in section 5 with discussion and future work.

## II. 2. QUERY AWARE RUMOR ROUTING

Rumor routing is a data centric routing algorithm. Such algorithms are used in networks where nodes are unaware of their geographical location. In Rumor routing, rumor is information about the event or a query for certain events, which is routed in the network. As nodes don't know the geographical location of destination or neighboring nodes, nodes transmit the information in the form of event or query agent. The node which generates the event is called the event node. Same way any node that wants to know about the event, will transmit the query agent and such a node is called the query node. In the network at the node where query agent and event agent meet each other or they both go through the path visited by each other they exchange the

information. By this they came to know about each other and thus the path is formed between event node and query node. Now the information will be passed through this path in both directions. Rumor routing is a logical compromise between event and query flooding. Following is list of terms we have use in our algorithm.

Table 1: Terms Used in Algorithm

<b>Event Agent</b>	An Event Agent is a packet that is responsible for spreading rumors about the events in the network. Each agent is associated with the time to live (TTL) that determines the number of hops that agent can traverse before it dies. An agent maintains an event list and a visited node history list.
<b>Query Agent</b>	A query is a request packet for receiving information on a particular event. Each query is associated with a time to live (TTL) that determines the number of hops the query can make. A query is considered undelivered when it does not reach its destination before the expiration of TTL. Like an event agent, a query agent also maintains a list of visited nodes or zones in a history list.
<b>Event List</b>	This list stores the event names and the distance to the events. Agents and nodes maintain their respective event lists.
<b>Neighbor List</b>	In case of Rumor Routing, neighbor list stores the node ids of the neighbors.
<b>History List</b>	In case of Rumor Routing, history list stores the node ids of the previously visited nodes. These lists maintain soft state information.
<b>Communication Range</b>	Communication range is the maximum distance that a node can send packet through wireless transmission. Therefore each node can send packet to other nodes that are within its communication range.
<b>Sensing Range</b>	This is the maximum range of each sensor node in which a sensor can detect the events. A sensor can detect multiple events occurring within its sensing range.
<b>Event path</b>	Along with spreading the rumor, the agent also constructs the event path, which is the shortest distance to the event the agent has discovered yet.

Thus the energy consumed by event node and query node for communication is  $N*V*I$ , where  $N$  is number of nodes over path

length and  $V$  is voltage needed for one node to transmit the data to the neighbor node on the path established by rumor routing and  $I$  is the drawn current.

*a) Optimized rumor routing algorithm:*

In the traditional rumor routing explained by [1], once the path is established between event node and query node, every query dispatched from query agent will go to event node for the information. In our algorithm we optimized the energy consumption of the network by using the knowledge available in query. We have classified the query in to two parts. This classification is based on the requirement of information for the particular event for which a query agent has been dispatched from a query node.

One type of the query needs the instantaneous information about an event (an over view of event) which is provided by the event agent when it meets the query agent while searching the path towards query. After that this query agent will come back to the query node. This kind of query agent does not need to go to the event node as its requirement of information is fulfilled. Total power consumed by this query is message transmission cost from query node to the meeting point of query agent and event agent. Here query need not have to go to event node so the total power consumption is lesser then the original rumor routing algorithm. Second type of agent needs the information about the event for the longer time span and asks for more information about the event. This kind of query agent will go to the event node because it needs more information about the event compared to instantaneous information oriented query agent. The query is classified before query node sends the query in the network. The result shows that the significant reduction in power consumption has achieved after applying proposed optimization technique in rumor routing algorithm on wireless sensor networks.

Let us take one simple exam suppose fire occurs at any node A, node B which is a query node needs information about the instantaneous temperature information at that node. Now for this information query agent of node B need not required to reach event node A. the information about the temperature will be available by the event agent itself. Now suppose the another query from the node B need the regular update on information about the temperature from the event node. In this case query agent requires going to the event node to make it aware of period event dispatch. This requires the same power as used in traditional Rumor routing Algorithm. In the following section we have shown the algorithms that runs our Query Nodes, Event Nodes and Intermediate Nodes.

### III. 3. ALGORITHM

In the above section gives the working principle of our optimized rumor routing algorithm. This work is complementary to the other suggested algorithms and helps in improving the performance of the rumor routing algorithm. In this section we have given the steps needed to perform at different nodes in the network.

#### A. Query Node:

Query node generates the query to get the information from network about the event. If path information about the event exists at query node then node takes next node to send query from that path, other wise they chose one of the neighboring node randomly and sends the query to that node. In the case if it receives the event information it store the path for the future use. The steps for the Query node are give below.

#### Steps for the Query Node

- 1 Set Communication Range
- 2 Set Query Frequency
- 3 Send  $k$  random Hello Packet
- 4 Wait for Neighbor Hello Packet for Predefine time
- 5 Set Query Type
- 6 Send Query Base on Query Type and Query Configuration
- 7 If Path present for event
- 8 Use neighboring node from path
- 9 Else
- 10 Select node randomly from neighbor list
- 11 Send Query with TTL
- 12 Repeat Step 8 base on Step 6
- 13 On Receive Event Agent
- 14 Get Path Information form Agent
- 15 Store information in list with purge time
- 16 On purge time Remove Entry from Query Node

#### B.

#### C. Source/Event Node:

Node that senses the environment and generative the data are called source nodes or event nodes. Event node sends the information toward the Query nodes in the event agents.

#### Steps for the Query Node

- 1 Set Communication Range
- 2 Set Event Frequency
- 3 Send  $k$  random Hello Packet
- 4 Wait for Neighbor Hello Packet for Predefine time
- 5 Set Event Type
- 6 Send Query Base on Query Type and Query Configuration
- 7 If Path present
- 8 Use next hop node from path
- 9 Else
- 10 Select Random Neighbor Node
- 11 Send Query with TTL
- 12 Repeat Step 11 base on Step 6
- 13 On Receive Event Agent
- 14 Get Path Information form Agent
- 15 Use this information for future with purge time
- 16 On purge time Remove Entry from Query Node

#### D. Intermediate Node:

Intermediate node receives the query agents and event agents and forwards them according to algorithm. In the case that node has query agent and receives the event agent it uses that information for query agent and forward the event on query path. On receiving query agent when it has related event agent it follows the same processer. In addition based on the query type it either forwards the query agent towards the event node or drops query agent and do not forward it.

#### Steps for the Intermediate Nodes

- 1 Receive the query and event agent
- 2 If only query or only event agent
- 3 Store the query and event agent
- 4 If TTL is not zero
- 5 Forward received query or event agent
- 6 Else
- 7 Drop query or event agent
- 8 Else
- 9 Forward query or event, base on received event or query information respectively
- 10 If long term query
- 11 Forward query to event node
- 12 Else
- 13 Drop query

Intelligent behavior of intermediate node based on query information helps the network to reduce the forwarded packets in the network.

#### IV. 4. RESULTS

In our simulation we have compared our query based Rumor routing algorithm with traditional Rumor routing algorithm. To compare both the protocols we have used the scalability of the network, transmission range of nodes and communication range as parameters. Algorithms are evaluated for the energy consumption requirement for different sets of parameters. In addition we have tested both the algorithms with different topological structures. For this purpose we took two topological structures one is grid and other is random node distribution. In our simulation for fix deployment region we have increased the node density per unit area, transmission range and query/event frequency and compared the standard rumor routing with our optimized rumor routing on the basis of energy consumption. In random node deployment we have assumed that for fixed power consumption per node, we are getting the connectivity which includes at least one node in its communication range.

Result in figure 1 shows the energy consumption in grid structure. Here we have increased the network size by increasing node density per unit area and analyzed the energy consumption of the network. Result shows that with optimization plotted in red line have lower energy consumption compared to without optimization shown in blue line. For random node deployment, the result is shown in figure 2.

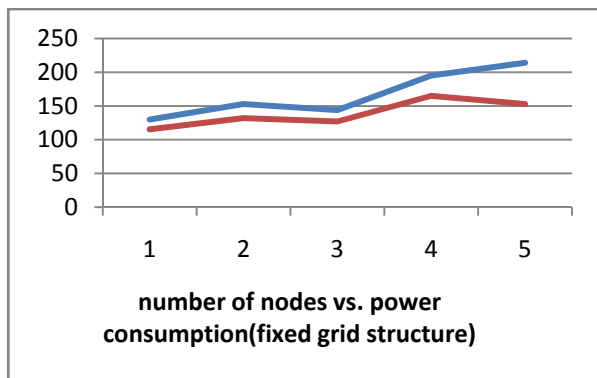

Figure 1: number of nodes vs. power consumption (fixed grid structure)

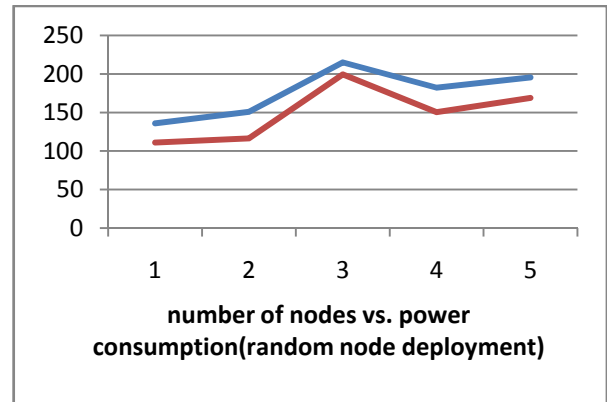

Figure 2: number of nodes vs. power consumption (random node deployment)

Here also red line shows the energy consumption due to optimized rumor routing while blue line shows the energy consumption due to traditional rumor routing. Result shows the significant reduction in energy consumption using optimized rumor routing algorithm.

The communication range is one of the parameter on which the network traffic depends on. For this query frequency is another parameter that we have used for comparing the both routing algorithms. The effect of communication on energy consumption has been evaluated both on grid as well as random structure. The figure 3 below shows the energy consumption for fixed grid structure for various communications ranges 6, 7, 8, 9, 10 and 11.

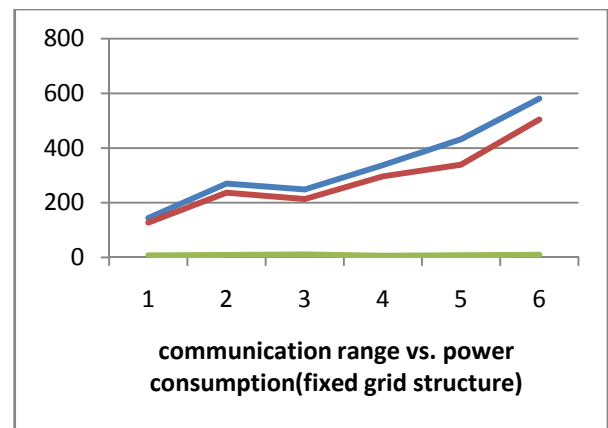

Figure 3: Communication range vs. power consumption for fixed grid structure.

For same ranges of communication we have changed the topological structure by random deployment. In both the figures red line shows the optimised rumor routing algorithm and blue line shows the traditional rumor routing algorithm.

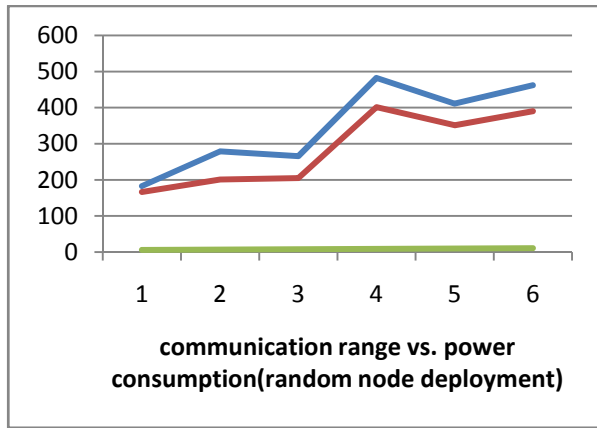

Figure 4: Communication range vs. power consumption for random node structure.

The significant improvement in energy consumption is clearly visible in all four graphs. The assumption over here is made that we can not take query node itself as event node. If we are taking a query node as event node also the results may differ.

#### Future work

We can change the query frequency (query agent per second) for single event as well as for multiple events. Also we can apply the above idea and algorithm for random and fixed grid structure.

#### V. CONCLUSION

In this paper we have proposed the query based Rumor routing algorithm which uses the information available in the query agent for the optimize routing. We have classified the query in two part instantaneous and long term queries. Based on this classification intermediate node makes their decision about the query forwarding. We have compared our algorithm with the tradition Rumor routing algorithm; simulation shows that our algorithm consumes the less energy and more energy efficient than the traditional algorithm.

#### VI. REFERENCES

- [1] Braginsky, D. and Estrin, D. 2002. Rumor routing algorithm for sensor networks. In *Proceedings of the 1st ACM international Workshop on Wireless Sensor Networks and Applications* (Atlanta, Georgia, USA, September 28 - 28, 2002). WSNA '02. ACM, New York, NY, 22-31. DOI=<http://doi.acm.org/10.1145/570738.570742>.
- [2] A. Colomi, M. Dorigo et V. Maniezzo, *Distributed Optimization by Ant Colonies, actes de la première conférence européenne sur la vie artificielle*, Paris, France, Elsevier Publishing, 134-142, 1991.
- [3] Okdem, S. and Karaboga, D. 2006. Routing in Wireless Sensor Networks Using Ant Colony Optimization. In *Proceedings of the First NASA/ESA Conference on Adaptive Hardware and Systems* (June 15 - 18, 2006). AHS. IEEE Computer Society, Washington, DC, 401-404. DOI=<http://dx.doi.org/10.1109/AHS.2006.63>
- [4] Li, X., Moaveninejad, K., and Frieder, O. 2003. Regional Gossip Routing for Wireless Ad Hoc Networks. In *Proceedings of the 28th Annual IEEE international Conference on Local Computer Networks* (October 20 - 24, 2003). LCN. IEEE Computer Society, Washington, DC, 274.
- [5] Lin, M., Marzullo, K., and Masini, S. 1999 *Gossip Versus Deterministic Flooding: Low Message Overhead and High Reliability for Broadcasting on Small Networks*. Technical Report. UMI Order Number: CS1999-0637., University of California at San Diego.
- [6] Intanagonwiwat, C., Govindan, R., and Estrin, D. 2000. Directed diffusion: a scalable and robust communication paradigm for sensor networks. In *Proceedings of the 6th Annual international Conference on Mobile Computing and Networking MobiCom '00*. ACM, New York, NY, 56-67. DOI=<http://doi.acm.org/10.1145/345910.345920>
- [7] Banka, T., Tandon, G., and Jayasumana, A. P. 2005. Zonal Rumor Routing for Wireless Sensor Networks. In *Proceedings of the international Conference on information Technology: Coding and Computing (Itcc'05) - Volume II - Volume 02* (April 04 - 06, 2005). ITCC. IEEE Computer Society, Washington, DC, 562-567. DOI=<http://dx.doi.org/10.1109/ITCC.2005.305>
- [8] Shokrzadeh, H., Mashaieki, M., Nayebi, A., Improving Directional Rumor Routing in Wireless Sensor Networks, *Conference on Innovations in Information Technology, 2007. IIT '07. 4th International* (Nov 18-20, 2007), 108-112.
- [9] Al-Karaki, J.N. Kamal, A.E., Routing techniques in wireless sensor networks: a survey, In *proceeding of IEEE Wireless Communications*, Vol 11, Issue 6, 6-28. Dec 2004.

# Fabrication of Macropore Arrays in Silicon

Mr Amit R Sharma

Asst Professor, E.C. Department, Ghandhinagar Institute of Technology, Ghandhinagar.  
amit.sharma@git.org.in

**Abstract:-The fabrication of macropore arrays in silicon by photo electrochemical etching technique in hydrofluoric acid (HF) solution is presented in this article. The formation of pore arrays with high aspect ratios by electrochemical etching of n-type silicon in hydrofluoric acid is a well established technique. The macropore morphology depends sensitively on the anodization conditions such as current density, etching time, HF concentration, light and bias voltage as well as on substrate properties such as orientation. When macroporous silicon is metallized with Nickel plating and filled with scintillating powder it acts as a waveguide for the visible light, and can improve X-ray detectors. By improving the quality of the macropores viz depth, width, flat wall, and flat bottom, one would improve the image quality of an X-ray detector.**

## 1. Introduction

This article is the result of a project in applied sensor technology at Mid Sweden University. The project is focused on the fabrication of macropores in silicon.

Fabrication of macropores by electrochemical etching in optional patterns pre-determined by photo-lithography has been known since 1990. The working of X-ray imaging detectors is based on this photo electrochemical growth process. V.Lehmann and U. Gruning<sup>[1]</sup> etched 2 $\mu$ m deep pores by using a 4 $\Omega$  n-type substrate. According to them the smallest pore diameter realized so far in a regular macropore array is about .3  $\mu$ m. Xavier Badel<sup>[2]</sup> achieved pore depth of 380 $\mu$ m, pore spacing of 30 $\mu$ m and wall of 3 $\mu$ m.

Macropores are useful in X-ray imaging detector. Different parameters like temp, time, voltage, current and conc. of HF solution can vary the quality of the macropores. The macropores were plated with Ni and filled with scintillating powder Terbium doped gadolinium oxysulphide (Gd<sub>2</sub>O<sub>2</sub>S:Tb). Then this device was tested for X-Ray sensitivity using dental X-ray source.

## 2. Electrochemical Etching of silicon

Electrochemical etching involves both acid and positive charged holes to dissolve the material. Silicone can be etched with hydrofluoric acid (HF), the etching rate can be controlled by adjusting the number of holes reaching the surface. One of several reactions that take place during the etching is:

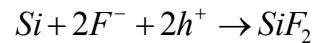

and



This uses two holes to dissolve one silicone atom. A similar reaction also takes place using four holes to dissolve one silicon atom. Other reactions are possible as there are many ions in the solution: (HF)<sup>2-</sup>, F<sup>-</sup>, OH<sup>-</sup>, F<sup>-</sup>, H<sub>3</sub>O<sup>+</sup>. Because the holes are used, new holes have to be supplied by external means. In n-type silicone holes are created by exposing the back of the wafer with light, a bias voltage move the holes to the surface of the wafer.

By measuring the current density and calculating the number of holes used during the etching, it is possible to decide which reaction is dominant. If the average number of holes used is close to two, this will result in porous etching of the silicon. Whilst if the number of holes is close to four, electro polished etching will occur. Between porous and electro polished etching there is an transition region where the current density is defined as J<sub>ps</sub>.

During etching of macropores the applied voltage will produce a "Space Charge Region"<sup>[3]</sup> that focuses the holes on to the tip of the pore, hence only at the pore tip etching will occur.

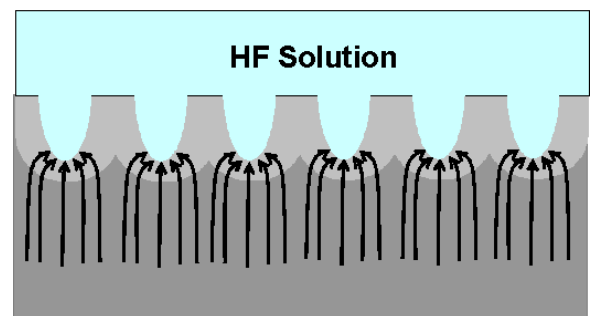

Figure 1

The current density at the pore's tip is equal to J<sub>ps</sub> and the number of holes used to dissolve a silicon atom is approximately 2.6 during macropore formation. An increase in the bias voltage will reduce the space charge region, this will increase the pore diameter and reduce the wall thickness.

### 3. Experimental process

N-type, <100> orientation, 1000Ωcm resistance silicon wafers were taken for the experiments. Pyramids were etched with KOH form a good start for macropores

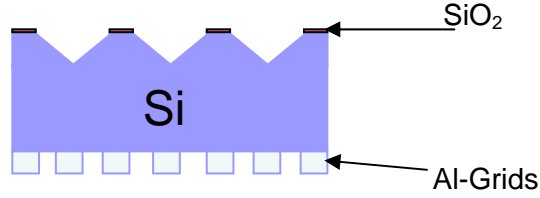

Figure 2 Cross-section of a wafer

The backside of the wafer is covered with Aluminium that supplies a good electrical contact for the bias voltage. In this case a halogen lamp was used on the backside providing the holes. So a grid of aluminium is made so light can get through and create holes.

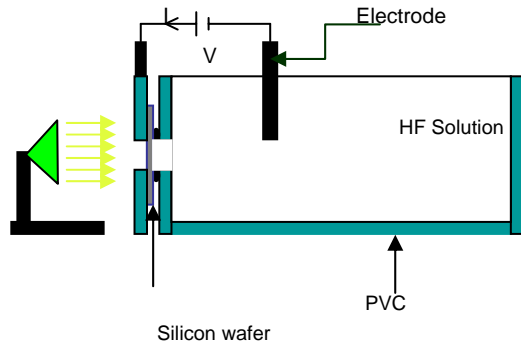

Figure 3 Experimental setup

The container is made of PVC which is resistant to HF. A platinum electrode are mounted which is used for bias voltage. The light source is located at the back side of the sample.

### 4. Equations

The HF concentration  $c$  in percentage of weight (wt% ), was calculated as follows:

$$c = \frac{1}{2} * \frac{(V_{HF50\%} * \rho_{HF50\%})}{V_{H_2O} * \rho_{H_2O} + V_{ethanol} * \rho_{ethanol} + V_{HF50\%} * \rho_{HF50\%}} \quad (\text{Eq. 1})$$

If the concentration of HF used in the experiment was 4.2 wt% then a total of 4dl solution was prepared for the experiment which includes 300ml of H<sub>2</sub>O, 100ml of ethanol and 30 ml of HF<sub>50%</sub> solution.

The critical current density in <100> N-type Si-wafer is calculated by:

$$J_{ps} = Cc^{3/2} * \exp(-E_a / kT) \quad (\text{Eq. 2})$$

$C = 3300A/cm^2$ ,  $c = \text{HF conc.}$ ,  $E_a = 0.345\text{eV}$  and  $k = \text{Boltzmann's constant}$ .

The pore diameter with square pores is calculated by:

$$d = p \sqrt{(J / J_{ps})} \quad (\text{Eq. 3})$$

$p = \text{spacing of the pores}$ ,  $J = \text{etching current}$ .

If the HF concentration is changed then the  $J_{ps}$  also changes, the new  $J_{ps}$  is calculated by:

$$J_2 = J_1 \times \left( \frac{c_2}{c_1} \right)^{3/2} \quad (\text{Eq. 4})$$

### 5. Metallization

The electroless Ni plating technique was used to metallize the macro porous silicon. The composition of the electroless Ni plating bath was essentially the same as that reported by S Dhar and S Chakrabarti. [4]

The temp of the bath is kept at room temp in a ultra sonic bath, and samples were kept in this solution for 10 min to 60 min.

When metallized the walls of pores acts as reflecting surface for the visible light, hence the porous silicon acts as a wave guide for the light concentrating it on the CCD.

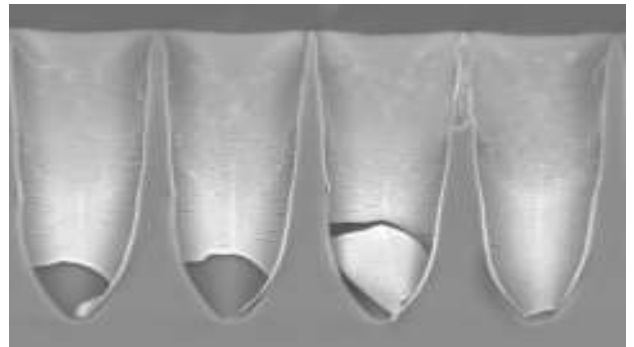

Figure 4 SEM picture of plated pores.

## 6. Macropore arrays as X-ray detector.

In the final step of our project we filled a macropore array with scintillating powder in order to check the performance of a macropore based sensor.<sup>[2]</sup> Due to limited time it was not possible to explore this area of the project fully. Scintillating powder is used to convert X-rays into visible light that can be collected by a CCD sensor.

Digital X-ray detectors based on macropore arrays with scintillating powder serves in two ways to reduce the X ray dose, at first they increase the resolution and secondly they reduce the duration of exposure, Since some Scintillating powder require less exposure than ordinary film imaging.

The problem aroused in properly filling the macropore arrays with scintillating powder. Ultra sonic vibrators can be used as a apparatus for filling macro pores but some modification of existing apparatus is required. There is also a need for properly measuring the different parameters that will categorize the performance of device.

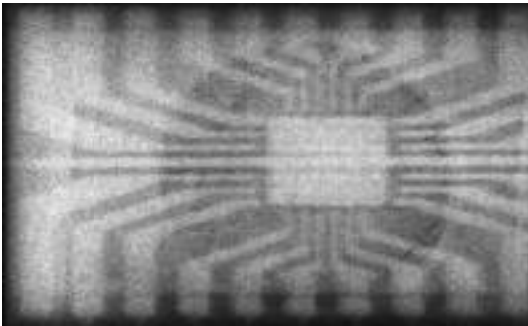
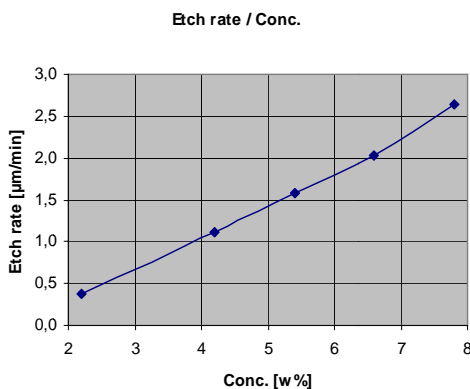

Figure 5 X-ray of an IC. The darker circle is the area with macropores that improve the contrast in the X-ray image.

## 7. Results

During electrochemical etching the number of silicon atoms dissolved is controlled by the current density. Our experimental result shows that the dept of the macropores was independent of the current applied during the etching. This is because the pore diameter is increasing when the current density is increasing according to Eq. 3. The area of the pore is equal to  $d^2$  if you have square pores. And the dept of the pores are independent of the current density.



By increasing the concentration of the HF solution the etch rate can be increased. Our experiments showed good linearity between HF concentration and reached dept.

Figure 6

Higher concentrations needs more holes and if you cant supply enough holes the wall quality may degrade. Figure 7 and 8 shows SEM images of the tip of two macropore's. In figure 8 higher concentration have been used and the current used was recalculated according to Eq. 4 to match the current in figure 7

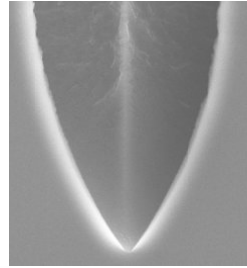

Figure 7

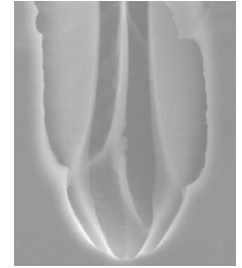

Figure 8

Figure 9 and 10 shows SEM images of pores etched with different current density.

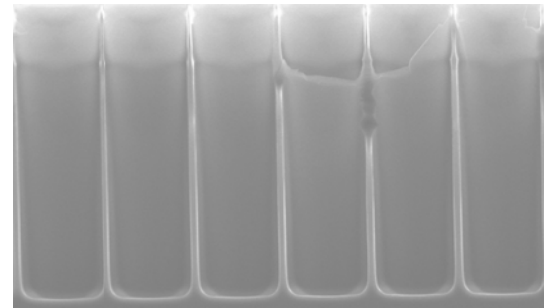

Figure 9 Current = 56mA, HF Conc = 4.2%wt, Time = 120 min

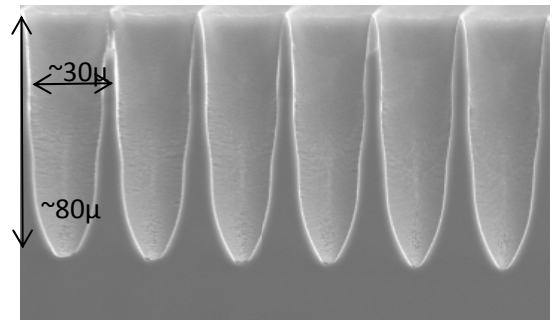

Figure 10 Current = 48mA, HF Conc = 4.2%wt, Time = 120 min



High current density led to more electro polishing which explains the flat pore bottoms and the thinner walls.

## 8. Conclusion

I successfully fabricated macropores over 310  $\mu\text{m}$  deep.

From the above experiment it can be inferred that current does not effect the etch rate. The etch rate is dependent on HF concentration. And we get deeper pores when the setup is kept for longer period of time.

The polishing of the pores depends on the current. At high current we got thin walls and flat bottoms as can be seen in figure 9.

Little time was used fore metallization and the plating process was not optimized for plating of macropores. There for the plating result was not as good as expected.

We were unable to completely fill the pores with scintillator powder. Due to limited time no effective method for filling pores were found. So the X-ray detector was not working satisfying.

## Acknowledgments

I am thankful to Göran Thungström myr teacher who gave me technical support and Henrik Andersson my supervisor for specially helping in clean room lab. I am also thankful to Mid-Sweden University for providing me with good computer and lab facilities.

## References

- [1] The limits of macropore arrays formation by V. Lehmann and U. Gruning
- [2] Development of macropore arrays in silicon and related technologies for X-ray imaging applications by Xavier Badel, KTH , Royal institute of Technology
- [3] Porous silicon – A new material for mems by V. Lehmann
- [4] Electroless Ni plating on n- and p-type porous Si for ohmic and rectifying contacts by s Dhar and S Chakrabarti.

# ANALYSIS OF MAGNETIC FLUID BASED SQUEEZE FILM BETWEEN TWO CURVED CIRCULAR PLATES

Nikhilkumar D. Abhangi<sup>1</sup>, G.M. Deheri<sup>2</sup>, Chandaniben D. Changela<sup>3</sup>

<sup>1</sup> Gandhinagar Institute of Technology, Gandhinagar, Gujarat, India,

<sup>2</sup> Department of Mathematics, Sardar Patel University, V.V.Nagar, Gujarat, India,

<sup>3</sup> Gandhinagar Institute of Technology, Gandhinagar, Gujarat, India, changela.

nikhil.abhangi@gmail.com, gmdeheri@gmail.com, [chandni@gmail.com](mailto:chandni@gmail.com)

**ABSTRACT:** Efforts have been directed to study and analyze the behavior of a magnetic-fluid-based squeeze film between curved rough circular plates when the curved upper plate (with surface determined by an hyperbolic expression) approaches the stationary curved lower plate (with surface governed by a secant function). The lubricant used is a magnetic fluid in the presence of an external magnetic field oblique to the radial axis. The associated Reynolds equation is then solved with appropriate boundary conditions to obtain the expressions for pressure and load carrying capacity. The numerically computed results are presented graphically. It is found that load carrying capacity increases with increasing magnetization. Further, it is seen clearly from the figures that the performance of the bearing system gets significantly enhanced due to the magnetization. It is observed that the load carrying capacity increases with respect to the curvature of the upper plate while a symmetric distribution takes place with regard to the lower plate's curvature parameter.. The analysis as well as the figures suggests that the bearing performance might be improved considerably by a proper choice of both curvature parameters in the presence of a magnetic fluid as lubricant. In addition this article also provides some measures to extend the life period of the bearing system.

## 1. INTRODUCTION

Murti [1] discussed the squeeze film behavior between a curved upper plate and a flat lower plate and established that the load carrying capacity rose sharply with curvature in the case of concave pads. Gupta and Vora [2] studied the corresponding problem for annular plates. In the above studies the lower plate was considered to flat one. Ajwaliya [3] analyze the problem of squeeze film behavior by modifying the approach of Gupta and Vora [2] taking the lower plate also curved. According to his investigations such situation could be found useful in design of machine elements like clutch plates and collar bearings. In all the above investigations conventional lubricants were used. Verma [4] and Bhat and Deheri [5] analyzed the squeeze film behavior between porous plates. It was concluded that the application of magnetic fluid lubricant enhanced the performance of squeeze film. However they assumed that the plates were flat. But in actual practice, the flatness of the plate does not endure owing to

elastic, thermal and uneven wear effects. With this end in view, Patel and Deheri [6] analyzed the behavior of the magnetic fluid based squeeze film between curved plates determined by secant functions. They found that the magnetic fluid lubricant improved the performance of the bearing.

Here an attempt has been made to deal with the performance of a magnetic fluid based squeeze film between a curved upper plate lying along a surface determined by hyperbolic function and a curved lower plate along the surface governed by secant function.

## 2. ANALYSIS

The configuration of the bearing is as shown in Figure 1. It is assumed that the upper plate lying along the surface given by

$$Z_u = h_0 \left[ \frac{1}{1 + Br} \right]; 0 \leq r \leq a \quad (1)$$

Approaching the lower plate lying along the surface

$$Z_l = h_0 \left[ \sec(-Cr^2) - 1 \right]; 0 \leq r \leq a \quad (2)$$

with the normal velocity  $\dot{h}_0 = \frac{dh_0}{dt}$ , where  $h_0$  is the central distance between the plates, and  $B$  and  $C$  are the curvature parameters of the corresponding plates. The central film thickness  $h(r)$  then is defined by

$$h(r) = h_0 \left[ \frac{1}{1 + Br} - \exp(-Cr^2) + 1 \right]. \quad (3)$$

Assuming axially symmetric flow of the magnetic fluid between the plates under an oblique magnetic field

$$\vec{H} = (H(r) \cos \varphi(r, z), 0, H(r) \sin \varphi(r, z)),$$

whose magnitude  $H$  vanishes at  $r = a$ , the modified Reynolds equation governing the film pressure  $p$  is [4, 5, 6] obtained as

$$\frac{1}{r} \frac{d}{dr} \left[ rh^3 \frac{d}{dr} \left( p - \frac{1}{2} \mu_0 \bar{\mu} H^2 \right) \right] = 12\mu \dot{h}_0 \quad (4)$$

where  $\mu_0$  is the free space permeability,  $\bar{\mu}$  is the magnetic susceptibility and  $\mu$  is the fluid viscosity. Taking, for instance

$$H^2 = a(a - r) \quad (5)$$

and remembering that the magnetic field arises out of a potential, it can be shown that  $\varphi$  the inclination angle satisfies the equation

$$\cot \varphi \frac{\partial \varphi}{\partial r} + \frac{\partial \varphi}{\partial Z} = \frac{1}{2(a - r)} \quad (6)$$

whose solutions are

$$C_1^2 \operatorname{cosec}^2 \varphi = a - r \quad \text{and} \quad Z = -2C_1 \sqrt{(a - C_1^2 - r)}$$

$C_1$  being a constant of integration.

Introducing the dimensionless quantities

$$\bar{h} = \frac{h}{h_0}, \quad R = \frac{r}{a}, \quad \mathbf{B} = Ba, \quad \mathbf{C} = Ca^2, \quad \mu^* = -\frac{\mu_0 \bar{\mu} h_0^3}{\mu \dot{h}_0} \quad (7)$$

and solving the Reynolds equation (4) using Equations (3) and (5) in view of the boundary conditions

$$P(1) = 0, \quad \frac{dP}{dR} = -\frac{\mu^*}{2} \quad \text{when} \quad R = 0 \quad (8)$$

(which physically mean that the pressure vanishes on the boundary of the bearing and that there is a radial flow from the axis due to magnetization), the dimensionless pressure and load carrying capacity obtained respectively form

$$P = -\frac{h_0^3 p}{\mu a^2 \dot{h}_0} = \frac{\mu^*}{2} (1 - R) + 6 \int_0^R \frac{R}{h^3} dR \quad (9) \quad \text{and}$$

$$\bar{W} = -\frac{Wh_0^3}{2\pi\mu a^4 \dot{h}_0} = \frac{\mu^*}{12} + 3 \int_0^1 \frac{R^3}{h^3} dR \quad (10)$$

### 3. RESULTS AND DISCUSSIONS

Expressions for dimensionless pressure  $P$  and load carrying capacity  $\bar{W}$  are presented in equation (9) and (10) respectively. From these two expressions it is clearly seen that the pressure increases by

$$\frac{\mu^*}{2} (1 - R)$$

while the increase in load carrying capacity is

$$\frac{\mu^*}{12}$$

as compared to the case of conventional lubricant.

Figures 2-3 present the variation of load carrying capacity with respect to the magnetization parameter for various values of the upper plate's curvature parameter and lower plate's curvature parameter respectively. It is clearly seen that the load carrying capacity increases significantly with increasing values of magnetization parameter. In Figures 3-4 once can visualize the effect of the curvature parameters on the load carrying capacity. The upper plate's curvature parameter increases the load carrying capacity while the lower plate's curvature parameter decreases the load carrying capacity. Further, the negative curvature of the lower plate tends to increase the load carrying capacity. Besides, the effect of  $\mu^*$  is negligible up to the value 0.01. Further the symmetric distribution is with respect to lower plate curvature parameter (Figure 4).

### 4. CONCLUSION

This article reveals that the performance of the bearing system can be improved considerably by choosing the magnetization parameter and curvature parameters of both the plates suitably.

## 5.REFERENCES

- [1] Murti, P.R.K., Squeeze films in curved circular plates, *J.Lubr.Technology*.97 (4), p. 650, 1975.
- [2] Gupta, J.L. and Vora, K.H., Analysis of squeeze film between curved annular plates, *J. Lubr.Technology*. 102, p. 48, 1980.
- [3] Ajwaliya, M.B., Behavior of squeeze films between two curved plates, Ph.D. Thesis , S.P.University, V.V.Nagar, 1984.
- [4] Verma, P.D.S., Magnetic fluid based squeeze film, *Int. J.Engng. Sci.* 24(3), p. 395, 1986.
- [5] Bhat, M.V. and Deheri, G.M., Squeeze film behavior in porous annular discs lubricated with magnetic fluid, *Wear*, 151, p. 123, 1991.
- [6] Patel, R.M. and Deheri, G.M., Magnetic fluid based squeeze film between two curved plates lying along the surfaces determined by secant functions, *Indian Journal of Engineering & Material Sci.*,Vol. 9, February, p. 45-48,2002.

Figure: 1 Configuration of the bearing system.

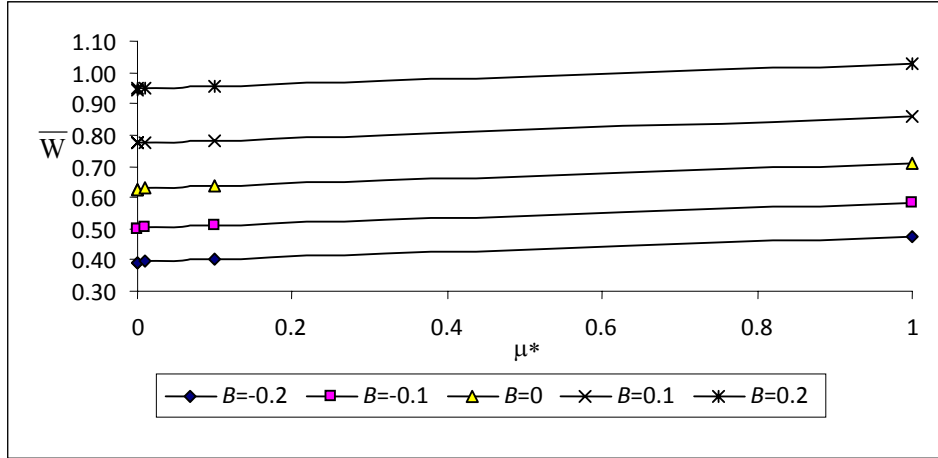

Figure: 2 Load carrying capacity with respect to  $\mu^*$  and  $B$

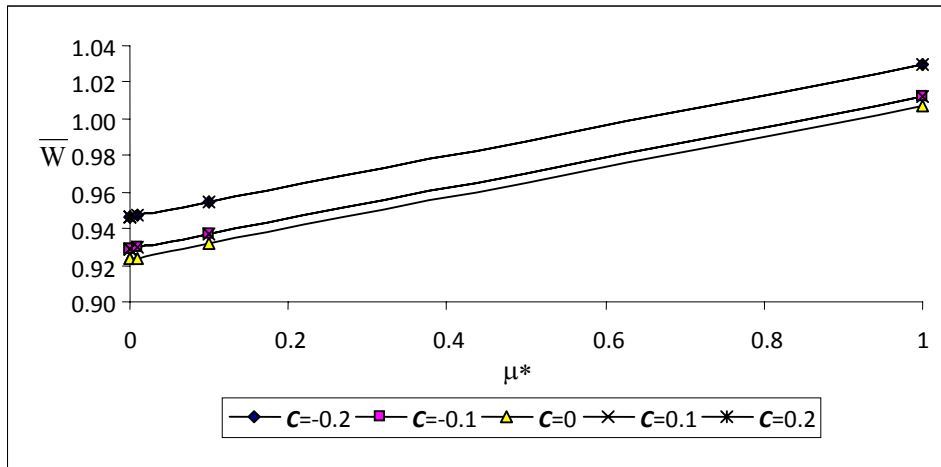

Figure: 3 Load carrying capacity with respect to  $\mu^*$  and  $C$

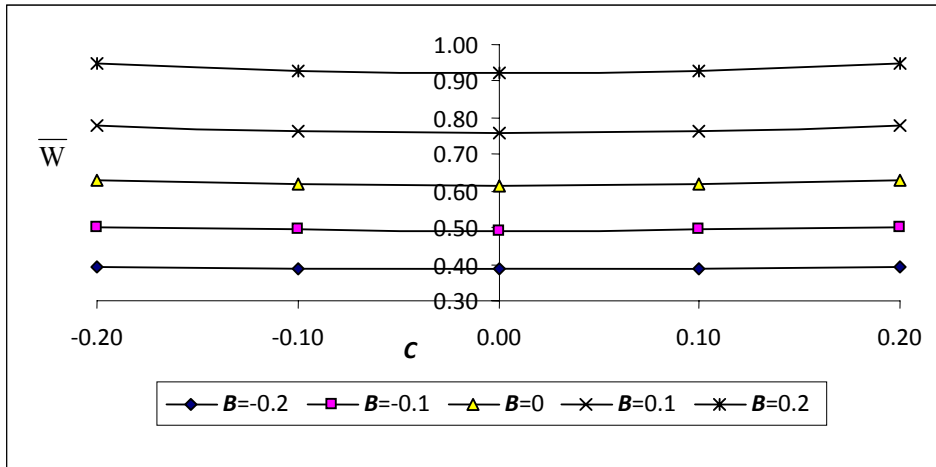

Figure: 4 Load carrying capacity with respect to  $C$  and  $B$

# APPLICATION OF SOLAR POWERED SEED SPRAYER IN AGRICULTURE – AN OVERVIEW

Milan J. Pandya <sup>1\*</sup>, Shaival R. Parikh <sup>2</sup>

<sup>1</sup> Lecturer, Mechanical Engineering Department, Gandhinagar Institute of Technology.

<sup>2</sup> Lecturer, Mechanical Engineering Department, Gandhinagar Institute of Technology.

\*Corresponding author (E-mail: milan.pandya@git.org.in)

## ABSTRACT

**This review paper deals with the design and working of “Solar Powered Seed Sprayer”. The solar seed sprayer is mainly use for agricultural purpose. It works under non-conventional energy which is the ultimate source for all living beings. The solar energy is converted into electrical with the help of solar cells. The converted electrical energy is completely stored in the battery and utilized to run a D.C. motor. Different kind of seeds can be sowed using this sprayer unit which also includes spraying solid substances and powder particles. It can be operated by a single person and is capable of covering an area of 6 hectares land in a single day.**

Key words: Solar seed sprayers, solar cell, lead acid battery, D.C. motor and hopper.

## INTRODUCTION

It is often said that food, clothing and shelter are the three basic needs of man kind. All the above three are based on agriculture. Agriculture is known to our people for thousands of years. But still our farmers in the villages are using only old-age technology. The population in our country has increased at least 3 times since our independence. The agricultural land has diminished in size and these lands have been diverted for industrial and domestic purposes.

For improving the productivity of our agricultural lands, it is stressed that they might employ high technology in every activity. Hence it will be in the fitness of things to design a device which can be operated annually. Therefore the idea of solar

powered seed sprayer becomes very helpful. Agriculture starts with sowing of seeds and fertilizers

and this particular activity have to carry out several times.

Hence if manually operated sprayer is designed it will prove to be a small but very effective step for achieving a high potential in growth.

### • *Solar Energy – A Boon to Mankind.*

Solar radiation is among the promising new source of energy. India receives annually over 60 x 1000 MWH of solar radiations with a span of 3000 – 3200 hrs. in Rajasthan, Gujarat, West of Madhya Pradesh and North of Maharashtra. Also around 2600 – 2800 hrs in the rest of the country excepting Kerala, Assam and Kashmir. Energy from the sun can be utilized in multi-various ways. It can be tapped directly from solar radiation in the form of thermal, thermodynamic and photo voltaic energy and indirectly through other related sources like wind, hydro power and ocean energy available on the planet Earth. The contribution of these sources in the total consumption of energy in the world is about 15 % only.

Traditionally, the utilization of solar energy has been confined to drying of agricultural products such as grains, maize, paddy, ginger, cashew, pepper, tobacco, fish and food drying. Its commercial application has been limited to production of common salt and other marine chemicals like potash, cromide and magnesium salts.

### Applications of Solar Technology.

- Solar water heating
- Space heating
- Space cooling
- Solar energy – thermal electric conversion
- Solar energy – photo voltaic electric conversion
- Solar distillation
- Solar pumping
- Agriculture and industrial process heating
- Solar furnace
- Solar cooking
- Solar production of hydrogen
- Solar green houses and the list goes on.

### DIRECT UTILIZATION OF SOLAR ENERGY

The most useful way of harnessing solar energy is by directly converting it into electricity by means of solar photo – voltaic cells. Sunshine is incident on Solar cells. In this system of energy conversion, direct conversion of solar radiations into electricity is carried out.

In recent year’s photo – voltaic power generation has been receiving considerable attention as one of the more promising energy alternatives. The reason for this rising interest lies in PV’s direct conversion of sunlight to electricity. The non polluting nature of the PV has increased its use considerably. Hence forth the low cost of conventional energy sunlight has obviated the development of a broad – based PV technology. At the present time, the PV generation can be justified only for special situations mostly for remote sites where utility lines on other conventional means of furnishing energy may be comparatively expensive and is one of the most attractive non-conventional energy sources of proven reliability from the micro to the mega watt level.

Like other energy system, this particular system also has some disadvantages.

1. Distributed nature of solar energy.
2. Absence of energy storage.
3. Relatively high capital cost.

### DESIGN OF SOLAR POWERED SEED SPRAYER

The design of the seed sprayer operated by the solar energy is very simple and also requires less operating cost. The following are the main components of the seed sprayer device.

1. Solar panel
2. Panel stand
3. Connecting wire

4. D.C. motor
5. Blower
6. Battery
7. Hose
8. Seeds
9. Hooper
10. Adjustable screw
11. Seed splitter

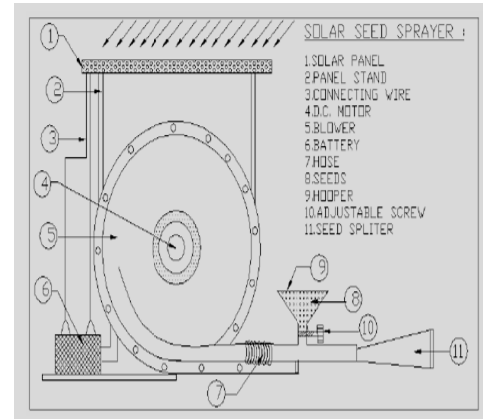
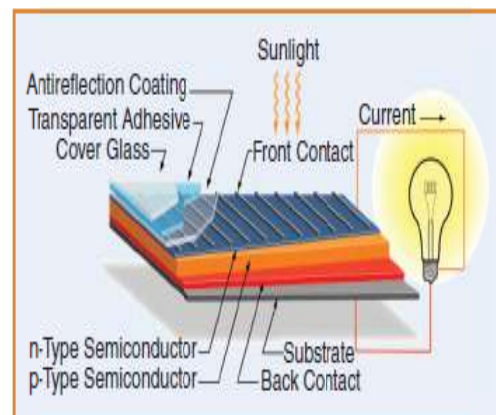

**Fig. 1.0 Design of solar powered seed sprayer**

The functions of the different components are as follows:-

#### 1. Solar panel.

The photo voltaic effect can be observed in nature in a variety of materials that have shown the best performance in sunlight. When the photons from the sun are absorbed in a semi conductor, that create free electrons with higher energies than the created, there must be an electric field to induce these higher energy electrons to flow out of the semi – conductor to do the useful work. A junction of materials which have different electrical properties provides the electric field in most solar cells.



**Fig. 2.0 Basic components of a photo voltaic cell**



## 2. Panel stand

It is used for providing the platform to the panel of the photo voltaic cells. It is made from mild steel material.

## 3. Connecting wire

It just transfers the current generated by the solar cells to the battery.

## 4. D.C. motor

A 12 V D.C. motor is used is used to run the blower fan. It runs with the help of the current supplied by the battery.

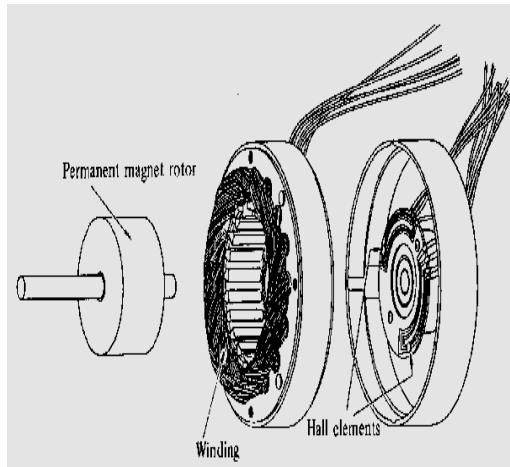

**Fig. 3.0 Exploded view of a D.C. brushless motor**

## 5. Blower

It is just used for providing the necessary force for the spraying of the seed or fertilizers.

## 6. Battery

The function of the battery is to provide current to the D.C. motor for its effective running. The battery used in the device is the lead – acid battery. The positive and negative electrodes of a lead acid battery are immersed in dilute sulphuric acid. Then the battery is fully charged, there is lead peroxide on the positive plate and the spongy lead on the negative plate as the active materials.

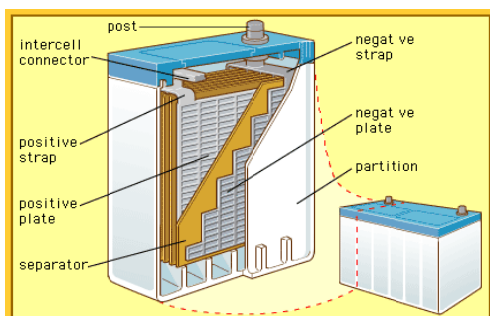

**Fig. 3.0 Exploded view of a general battery**

## 7. Hose

It is used for the connection purposes.

## 8. Hooper

It is a funnel – shaped device where the seeds or fertilizers to be sprayed are stored.

## 9. Adjustable screw

When the speed of the seeds sprayed is to be increased or decreased, it is done with the help of the adjustable screw fitted on the lower part of the hopper.

## 10. Seed splitter

It is the device through which the seeds are sprayed to a particular destination.

## WORKING OF SOLAR POWERED SEED SPRAYER

The blower fan is made to rotate by using a 12 V D.C. motor. The supply of the current is been given from the 12 V lead – acid battery provided. The chemical liquid (seeds or fertilizers) provided in the hooper may reach the nose for the spray by the gravitational force. The panel of photo voltaic cells is fixed by providing the M.S. plates. During the sunshine, the panel board absorbs the heat energy from the sun and it converts it to the electrical energy and sends these current to the battery for the storage provision. The stored energy from the battery is supplied to the motor for operating the blower fan. The discharge of the electrical energy from the battery will be equal to the charging of the battery by the solar photo voltaic cell.

## ADVANTAGES

- Since the efficiency of the sprayer is very high, it can be used by the farmers.
- The materials spread uniformly.
- This device is portable.
- It is light in weight.
- Unskilled workers can also operate it effectively.
- Low operating and maintenance cost.
- This device works on non - conventional energy source (i.e. Sun).
- Maintenance is comparatively easy.
- This device is pollution free as there is no combustion of fuel.
- This device can be used for small and large scale.

## **CONCLUSION**

Today as we are facing the problems of the Global Warming, the concept of the Solar operated Seed Sprayer gives a good alternative for future use. Also this device is much useful in the agricultural countries like India. This device is simple and can be easily operated. Also the results have proved that the working of this sprayer is quite satisfactory for most of the seeds and fertilizers to be sprayed very frequently. Moreover the device can also be modified as per the requirements of the demand by changing the motor and battery capacity. Further developments can also be done in the design of the seed sprayer for increasing the efficiency of the sprayer.

## **REFERENCES**

- [1] C.P. Malik, S.K. Thind and D.S. Bhatia, "Alternating plant archetype with plant growth regulators", Agro's Annual Report of Plant 36 (4), 1995.
- [2] K.K.G. Menon and H.C. Srivastava, "Increasing plant productivity through improved production techniques", 1984.
- [3] C.P. Malik, U. Parmar, P. Singh, K.L. Ahuja and R.K. Raheja, "Henolic acid and aliphatic growth and oil production", Plant Growth Regulation Report – 2, 1985.
- [4] G.D. Rai, "Non – conventional sources of energy".
- [5] Aggrawal, "Solar Energy" an article.
- [6] S.K. Bose, "Solar Energy" an article.

# SOME ASPECTS RELATED TO FLOW SYSTEM TEST AND TURBOMACHINE SELECTION

**Mahesh J. Zinzuvadia,**  
B V M Engg. College,  
Dist. Anand, State- Gujarat,  
VALLABH VIDYANAGAR- 388120

## ABSTRACT

Many industrial applications use combination of Flow system and turbomachine to maintain required fluid flow rate. In these applications power consumption can be minimized by selecting appropriate turbomachine. In this paper, two Flow Systems are tested and potential uses of test results for prediction of Flow system characteristics and in selection of appropriate turbomachine are discussed.

## Introduction

Power consuming fluid machines like pump, blower and fans are required to maintain flow through pipeline, duct or device. Here system made up by using pipeline, fittings and devices is known as Flow system and it is fitted externally with fluid machine.

## CHARACTERISTICS OF FLOW SYSTEM AND OPERATING POINT:

When fluid flows through the Flow system, head loss takes place. The head loss of the Flow system is there due to head loss given by all components of the Flow system. Head loss given by Flow system is also known as its resistance and for given Flow system it depends upon the flowrate through the system. The relationship between flowrate and resistance of Flow system is known as characteristic of flow system[1].

Characteristic of given Flow system can be obtained either analytically or by experimental method. Analytical method is used for simple duct-like system only, while experimental method is used for Flow systems having more complexity. In experimental method, head loss of the Flow system is calculated by using measured values head at inlet and outlet of the Flow system at different flowrates. As resistance of Flow system is proportional to square of flowrate, system characteristic curve will be parabolic.(Fig.1)

When flow system is connected with any power consuming turbomachine, pressure developed by turbomachine should be same as pressure drop of the flow system. This condition is satisfied at Operating point of machine-system combination. Thus operating point is point of intersection of Flow system characteristic and turbomachine characteristic(Fig.1).

Operating point of the machine-system combination may or may not coincide with best efficiency point(b e p).When appropriate turbomachine is selected, Operating point will coincide with b e p and turbomachine will consume minimum power while maintaining required flowrate[2].

## EXPERIMENTAL SET UP AND RESULTS:

The tests were carried out on a Flow system comprising of pipeline, valve and nozzle. Flow system was fitted at blower outlet and flowrate through the Flow system was varied by partial closing of blower inlet in steps. Total head at Flow system inlet and that at Flow system outlet were measured by Prandtl's pitot tube at different flowrates. From the observations resistance of the flow system and flowrate were calculated to obtain Flow system characteristic. Different openings of valve give different flow systems and two such Flow systems were tested. Fig.2 shows experimental results graphically.

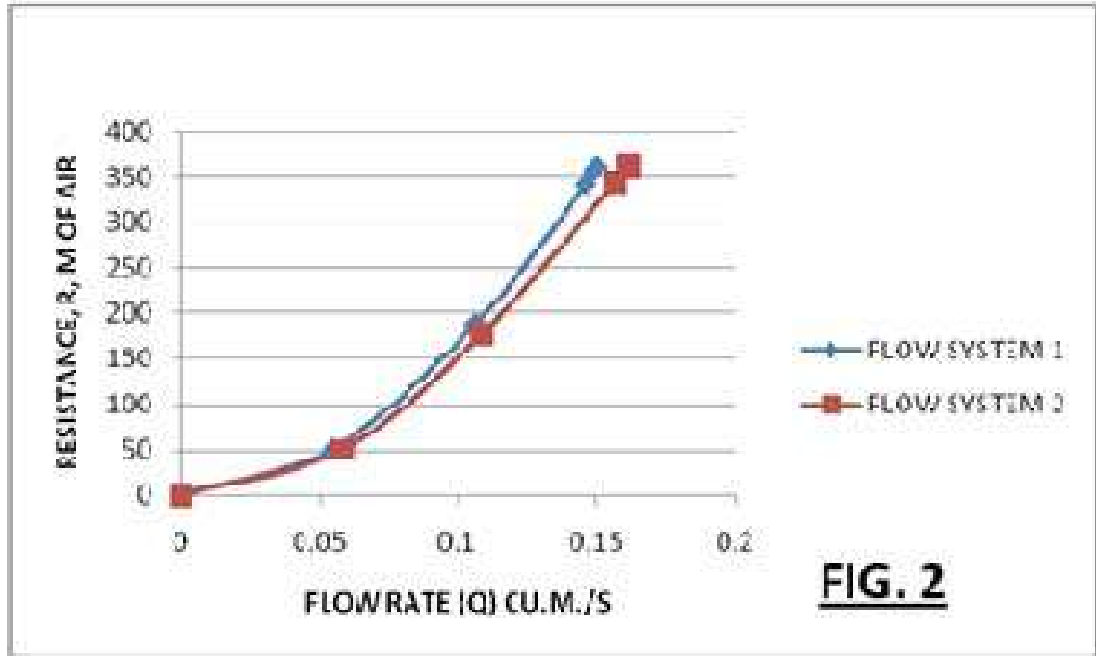
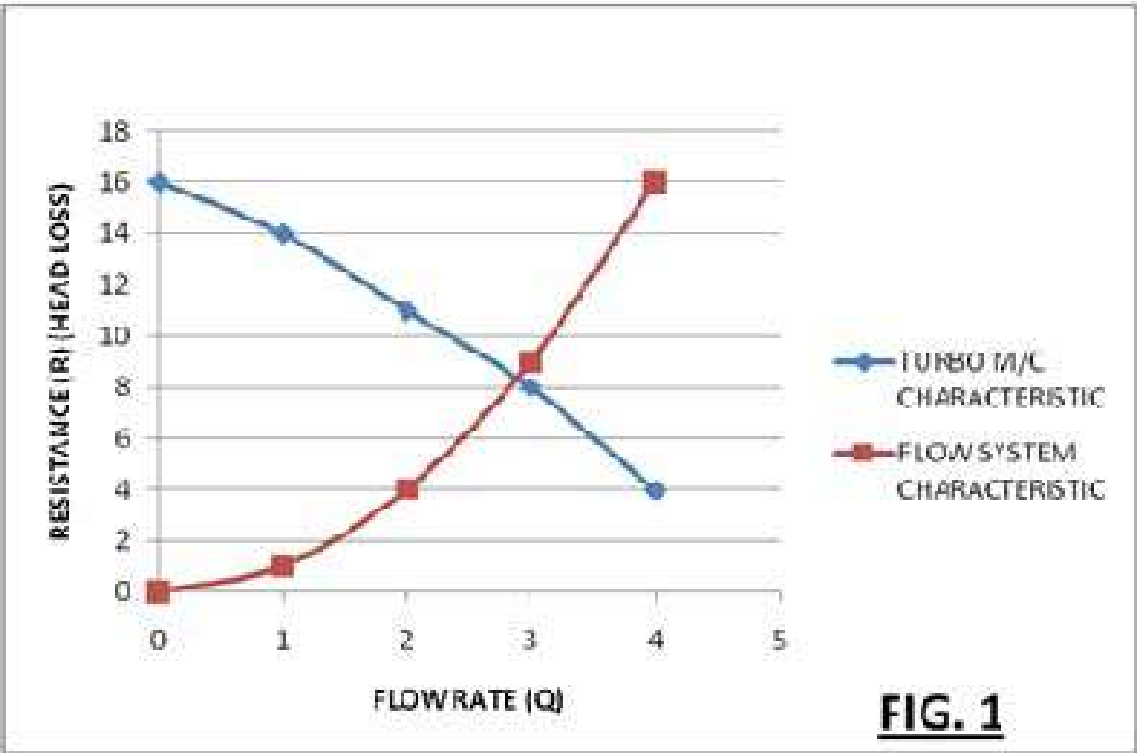

## **DISCUSSION AND CONCLUSION:**

When different Flow systems are obtained by different valve openings, experimental testing can be replaced by suitable method of prediction also. The results obtained here are useful to find accuracy of predicted results.

Characteristics of Flow systems shown in Fig.2 are useful to select appropriate turbomachine to maintain required flowrate. Steps of selection procedure will be as below:

- (1) Obtain system characteristic curve of given Flow system experimentally.
- (2) Considering the application, find required value of flowrate ( $Q_1$ ), e.g. for air-conditioning application, cooling requirement gives necessary air flowrate.
- (3) Find resistance ( $R_1$ ) corresponding to flowrate ( $Q_1$ ) from system characteristic Curve.(Fig.1)
- (4) Select the turbomachine, which has flowrate of  $Q_1$  m<sup>3</sup>/s and head equal to  $R_1$  m at Design point of turbomachine..

## **REFERENCES**

- [1] Essentials of Engineering Fluid Mechanics, Fourth Edition, pp.493-495.  
Reuben M. Olson.
- [2] Introduction to Fluid Mechanics, Fifth Edition, pp.531-540  
Robert W. Fox and Alen T. McDonald.



Platinum Foundation Managed

**GANDHINAGAR INSTITUTE OF TECHNOLOGY**

Approved by AICTE, Affiliated: Gujarat University and Gujarat Technological University

[About Us](#)

[Editorial Board](#)

[GIT Trustees](#)

[Editorial GIT JET  
Message](#)

[Content](#)

[Contact Us](#)

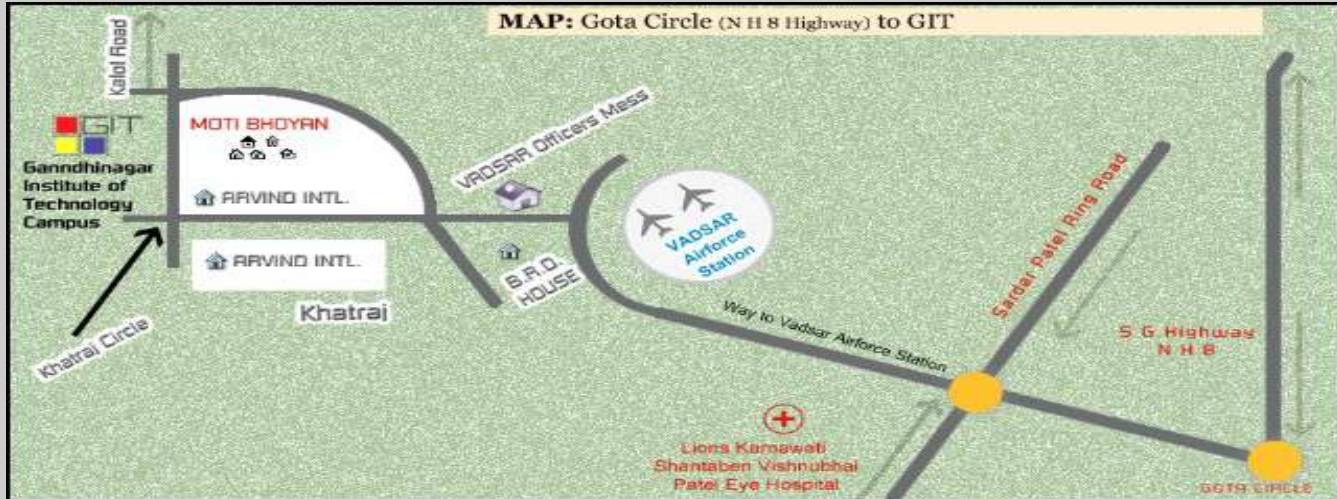

## Contact US

### Address:

Gandhinagar Institute of Technology  
Khatraj - Kalol Road,  
Village Moti Bhojan,  
Tal. Kalol  
Gandhinagar-382721

### Telephone No :

+91-02764-281860  
+91-02764-281861

**E-mail:** [director@git.org.in](mailto:director@git.org.in)

### Fax:

+91-02764-281862



Platinum Foundation Managed

**GANDHINAGAR INSTITUTE OF TECHNOLOGY**

Approved by AICTE, Affiliated: Gujarat University and Gujarat Technological University

[About Us](#)

[Editorial Board](#)

[GIT Trustees](#)

[Editorial GIT JET](#)

[Message](#)

[Content](#)

[Contact Us](#)



## About Gandhinagar Insitute of Technology

Gandhinagar Institute of Technology was established by Platinum Foundation Trust in December 2006. The Institute is affiliated to Gujarat Technological University and Gujarat University and approved by AICTE New Delhi. The Trust is registered under Public Trust Act, having Registration No. E-17490 dated 19 June 2006 at Ahmedabad, Gujarat.

The Institute aims to be a leading center for research and engineering study, pursuing knowledge in both fundamental and applied area, and collaborating closely with business and industry in promoting technological innovation and economic development. The members of the Trust are involved in social activities and are also contributing to the technical institutions development by raising funds and promoting the technical interest of state and country. Gandhinagar Institute of Technology is situated near Village "Moti Bhoyan" and 24 km away from Ahmedabad city.

It offers B.E Program in Mechanical, Electronics & Communication, Computer Engineering & Information Technology and Civil Engineering. It also offers MBA Program with specialization in Marketing, Finance, Human Resource Management and Information Systems. Gandhinagar Institute of Technology will nurture the intellectual growth of its students and serve humanity through creation, application and dissemination of knowledge relevant to technology and become one of the premier Engineering and Management Institutes and achieve the highest order of excellence in teaching.

## **EDITORIAL BOARD**

- Prof. M. N. Patel* : Principal, L. D. College of Engineering and  
Dean, Faculty of Engineering and Technology  
Gujarat University, Ahmedabad  
Acting Vice-Chancellor, Gujarat Technological University
- Dr. F. S. Umarigar* : Principal, BVM Engineering College and  
Dean, Faculty of Engineering and Technology,  
University, V V Nagar
- Dr. S. A. Puranik* : Director, Atmiya Institute of Science and Technology, Rajkot
- Dr. Ketan Kotecha* : Director, Institute of Technology, Nirma University  
Ahmedabad
- Dr. P. K. Shah* : Director, Silver Oak College of Engineering & Technology  
S.G. Highway, Ahmedabad
- Dr N M Bhatt* : Chairman & Convenor  
Principal, Gandhinagar Institute of Technology,  
Moti Bhojan, Ta. Kalol, Dist. Gandhinagar

### **Disclaimer**

Views expressed in the papers are solely from respective authors and editorial board has no responsibility of their authentication

This journal is being published in the interest of research community for private circulation only



[About Us](#)[Editorial Board](#)[GIT Trustees](#)[Editorial GIT JET  
Message](#)[Content](#)[Contact Us](#)

## GIT Trustee's

GIT Trustee's

**Shri Harishbhai B. Rohera****Qualifications** : B. Com**Position** : Member - Board of Trustee & Advisory Board**Background**

- » Proprietor: Mahadev Steel Suppliers
- » C/o: Vinayak Steel Syndicate
- » C/o: Dhiraj Steel Supplier
- » C/o: Krishna Steel Trader
- » Owner: National Steel Processor
- » Trustee: Sai Vasant Ghot Darbar
- » Trustee: Jai Jhulelal Mandir

**Shri Dipakbhai N. Ravani****Qualifications** : B.Com., LL.B.**Position** : Member - Board of Trustee & Advisory Board**Background**

- » Business

**Shri Pravinbhai A. Shah****Qualifications** : B.A., LL.B.**Position** : Member - Board of Trustee & Advisory Board**Background**

- » President of Zalavad Samaj Jain Seva Trust
- » Trustee of Vasant Atma Charitable Trust
- » Trustee of Rampura Champa Vijya Hospital
- » Trustee of Shantivan & Ambawadi Jain Sangh
- » Trustee of Rampura Kelavani Mandal
- » Trustee of Pampura Panjrapole Trust

**Shri Gahanshyambhai V. Thakkar****Qualifications** : M.A**Position** : Member - Board of Trustee & Advisory Board**Background**

- » Professor at Vivekanand College of Arts, Ahmedabad
- » Ex. M.L.A., Gujarat Assembly from Mandal
- » Trustee of V.M. Thakkar Charitable Trust, Ahmedabad
- » Manages Muktajeevan Vidhyalaya and BVD High School, Isanpur and Maninagar

- » Advisor/Member Kankaria Maninagar Nagarik Sahakari Bank
- » Director - Adarsh Co-Operative Departmental Stores

**Smt Varshaben M. Pandhi****Qualifications** : B.Com**Position** : Member - Board of Trustee & Advisory Board**Background**

- » Working experience in the field of Insurance and Investment Advisory for about 20 years

## Research Methods

**Research** is another word for gathering of information. The more information we have the closer we get of making our own decision. Research is the result of advancing knowledge created in the past. There are people from all walks of life that contribute to gathered information. These are ordinary people and extraordinary people. They include teachers, students, scientists, professors, scholars, business owners, librarians, book keepers, writers, politicians and many more unknown out there.



Research is designed to solve a particular existing problem so there is a much larger audience eager to support research that is likely to be profitable or solve problems of immediate concern. We also must understand how research impacts our decision making. Most people make decisions without gathered information to back them up. Only few do. Research requires time, effort, and sometimes money to have the evidence you need to make a sound decision that's why many avoid it. The research you do and evidence you gathered will have impact on your future. Be advised, considered the risks or consequences of making an important decision with inadequate evidence.

In conclusion research is very vital to our everyday decision making. It arms you from wrong information and save time and money. It is important to your success as you take on life's challenges and career decisions making. But be careful though, because too much research without action on what you're learning is not good either. The question is how much information is enough? How much information can you afford? Research plus action will most likely guarantee a successful research.

There are five fundamental research methods viz. (1) Experimental methods (2) Correlations (3) Naturalistic observation (4) Survey and (5) Case Study.

**Experimental Methods:** This method is one in which a researcher manipulates a variable (anything that can vary) under highly controlled conditions to see if this produces (causes) any changes in a second variable. The variable, or variables, that the researcher manipulates is called the independent variable while the second variable, the one measured for changes, is called the dependent variable. Independent variables are sometimes referred to as antecedent (preceding) conditions. All scientific disciplines use this method because they are interested in understanding the laws (cause-and-effect relationships) of nature. The power of the experimental method derives from the fact that it allows researchers to detect cause-and-effect relationships.

In order to see cause-and-effect relationships the researcher must be sure that his manipulations (the independent variable) are the only variables having an effect on the dependent variable. He does this by holding all other variables, variables that might also affect the dependent variable, constant (equivalent, the same). Only by this highly controlled procedure can the researcher be sure that the observed changes in the dependent variable were in fact caused by his manipulations. Experimental studies, therefore, are used when the researcher is interested in determining cause-and-effect relationships. Also, this method can be used when it is appropriate, both practically and ethically, to manipulate the variables.

However, a major limitation is that this method can only be used when it is practical and ethical for the researcher to manipulate the antecedent conditions. A second limitation to this method is that experimental studies are usually done in the highly controlled setting of the laboratory. These conditions are artificial and may not reflect what really happens in the less controlled and infinitely more complex real world.

**Correlations:** Correlation is classified as a non-experimental, descriptive method. The reason for that is because variables are not directly manipulated as they are in the experimental method. Although correlation is often described as a method of research in its own right, it is really more of a mathematical technique for summarizing data, it is a statistical tool. A correlational study is one designed to determine the degree and direction of relationship between two or more variables or measures of behavior.

The strength of this method lies in the fact that it can be used to determine if there is a relationship between two variables without having to directly manipulate those variables. In other words, correlation can be used when the experimental method cannot; correlation can be used when it is impractical and/or unethical to manipulate the variables. Correlation also can be used as a basis for prediction.

The greatest limitation of correlation is that it does not tell researchers whether or not the relationship is causal. In other words, correlation does not prove causation. It only shows that two variables are related in a systematic way, but it does not prove nor disprove that the relationship is a cause-and-effect relationship. Only the experimental method can do that.

**Naturalistic observation:** The naturalistic observation is a type of study classified under the broader category of field studies; non-experimental approaches used in the field or in real-life settings. In the naturalistic observation method the researcher very carefully observes and records some behavior or phenomenon, sometimes over a prolonged period, in its natural setting. The subjects or phenomena are not directly interfered with in any way. In the social sciences this usually involves observing humans or animals as they go about their activities in real life settings. In the natural sciences this may involve observing an animal or groups of animals or some physical phenomena, such as the eruption of a volcano.

The major strength of this method is that it allows researchers to observe behavior in the setting in which it normally occurs rather than the artificial and limited setting of the laboratory. Further uses might include studying nature for its own sake or using nature to validate some laboratory finding or theoretical concept.

One of the limitations is that this is a descriptive method, not an explanatory one. That is, without the controlled conditions of the laboratory, conclusions about cause-and-effect relationships cannot be drawn. Behavior can only be described, not explained. This method can also take a great amount of time. Researchers may have to wait for some time to observe the behavior or phenomenon of interest. Further limitations include the difficulty of observing behavior without disrupting it and the difficulty of coding results in a manner appropriate for statistical analysis.

**Survey:** The survey, another type of non experimental, descriptive study, does not involve direct observation by a researcher. Rather, inferences about behavior are made from data collected via interviews or questionnaires. Interviews or questionnaires commonly include an assortment of forced-choice questions (e.g. True-False) or open-ended questions (e.g. short answer essay) to which subjects are asked to respond. This sort of data collection is sometimes referred to as a self-report. Surveys are particularly useful when researchers are interested in collecting data on aspects of behavior that are difficult to observe directly and when it is desirable to sample a large number of subjects. Surveys are used extensively in the social and natural sciences to assess attitudes and opinions on a variety of subjects.

The major limitation of the survey method is that it relies on a self-report method of data collection. Intentional deception, poor memory, or misunderstanding of the question can all contribute to inaccuracies in the data. Furthermore, this method is descriptive, not explanatory, and, therefore, cannot offer any insights into cause-and-effect relationships.

**Case study:** This method is also a non-experimental, descriptive type of study. It involves an in-depth descriptive record, kept by an outside observer, of an individual or group of individuals. This often involves collecting and examining various observations and records of an individual's experiences and/or behaviors. Typical data collected might include biographical data, medical records, family history, observations, interviews, and the results of various psychological tests.

Case studies are particularly useful when researchers want to get a detailed contextual view of an individual's life or of a particular phenomenon. Case studies are also useful when researchers cannot, for practical or ethical reasons, do experimental studies.

This is a descriptive method, not an explanatory one. That is, without the controlled conditions of the laboratory, conclusions about cause-and-effect relationships cannot be drawn. Behavior can only be described, not explained. Case studies also involve only a single individual or just a few and therefore may not be representative of the general group or population. Also, much of the information collected is retrospective data, recollections of past events, and is therefore subject to the problems inherent to memory.

Dr N M Bhatt  
Principal

[About Us](#)[Editorial Board](#)[GIT Trustees](#)[Editorial GIT JET](#)[Message](#)[Content](#)[Contact Us](#)

Sr.	Title of Papers	Author	Institution	E-mail ID
1	<a href="#">Airo Static Stability Analysis of Long Span Suspension Bridges</a>	Prof. Niraj shah Associate professor and head	Charotar Institute of Technology, Changa	nirajshah.cv@ecchanga.ac.in
2	<a href="#">Flooding in Computer Network With Passive Clustering</a>	Mrs. Darshana Mistry	Computer Engineering Dept., Gandhinagar Institue Of Technology, Gandhinagar	darshana.mistry@git.org.in
3	<a href="#">Ann Based Intelligent Controllers For An Indirect Vector Controlled Three-Phase Induction Motor</a>	Ami Patel, Assistant professor Tejendra Patel, Surat P.G. Student	SVNIT, Surat	ami_engg86@yahoo.com ami.mgiter@gmail.com
4	<a href="#">Comparative Study of Web Services and Software oriented Architecture for Mobile Augmented Reality System</a>	Jatin Shah, MCA, Research Scholar, DR. Bijendra Agrawal Principal	VKMS College, Vadu	jatinshah79mca@gmail.com, bijendra_agrawal@yahoo.com
5	<a href="#">QUEST (Quick Unbiased Efficient Statistical Tree): An efficient algorithm of Classification Tree in Data Mining</a>	Mr. U. N. Parmar, Mr. A. K. Ranpura, Mr. V. K. Jadeja, Mr. R. P. Joshi	CCET, Wadhwan, Gujarat.	ureshparmar13@yahoo.co.in, vkjadeja_itworld@yahoo.co.in, rah1985@gmail.com
6	<a href="#">Performance Analysis of Gun-shot Direction Detection System for ak47 gun shot</a>	Anju M. Vasdewani Dr. G.R.kulkarni R.S.Gajre	C.U.Shah College of Engineering & Technology, Wadhwan City	grkulkarni29264@rediffmail.com rakeshgajre@gmail.com
7	<a href="#">Modified Bagging Method: A Novel Approach of Multiple Classification in Data Mining</a>	Mr. Uresh N Parmar Mr. Krunal G Patel, Ms Meenakshi	C.C.E.T, Wadhwan, Gujarat, India	ureshparmar13@yahoo.co.in kgp2003@gmail.com meenakshi.saroaha@gmail.com
8	<a href="#">Emission Scenario At Road Intersections - A Case Study Of Surat City</a>	Jayesh A. Shah Dr.F.S.Umrigar Dr L.B.Zala, Neeraj D.Sharma	V.B.T.Engg. College, Umrakh B.V.M Engg. College, V.Vidyanagar	
9	<a href="#">Performance Comparison of Space Time Codes</a>	Mrs. Anshu Shah	Gandhinagar Institue Of Technology, Gandhinagar	anshu.shah@git.org.in
10	<a href="#">Data Mining: Terms And Techniques</a>	Mr. Uresh N Parmar, Mr. Krunal G. Patel, Ms.Meenakshi Saroha, Mr. Nishidh S. Chavda	Asst. Prof., IT Department, CCET, Wadhwan, Gujarat, India Lecturer, IT Department, KITRC, Kalol, Gujarat, India Asst. Prof., CE Department, CIT, Changa, Gujarat, India	ureshparmar13@yahoo.co.in, kgp2003@gmail.com, meenakshi.saroaha@gmail.com, nishidhchavda.ce@ecchanga.ac.in
11	<a href="#">Some Aspects Related to Flow System Test and Turbomachine Selection</a>	M. J.Zinzuvadia, Lecturer,	B V M Engg. College, Vallabh Vidyanagar	mjzbvm@gmail.com
12	<a href="#">Optimized Rumor Routing Algorithm for Wireless Sensor Networks</a>	Zalak Modi, Sunil Jardosh, Prof. Prabhat Ranjan	Gandhinagr Institute of Technology, Gandhinagar	zalak_modi2000@yahoo.com
13	<a href="#">Fabrication of Macropore Array on Silicon</a>	Mr Amit R Sharma Asst Professor	Gandhinagr Institute of Technology, Gandhinagar	amit.sharma@git.org.in
14	<a href="#">Ananlysis of Magnetic Fluid Based Squeeze Film Between Two Curved Circular Plates</a>	Mr Nikhil Abhangi, Mrs Chandani Changela	Gandhinagr Institute of Technology, Gandhinagar	nikhil.abhangi@git.org.in chandani.chanela@git.org.in
15	<a href="#">Application of Solar Powered Seed Sprayer in Agriculture- An Overview</a>	Mr. Milan J. Pandya, Mr. Shaival R. Parikh	Gandhinagr Institute of Technology, Gandhinagar	milan.pandya@git.org.in

# AEROSTATIC STABILITY ANALYSIS OF LONG SPAN SUSPENSION BRIDGES

N D Shah<sup>1</sup> D A Shah<sup>2</sup> Dr J A Desai<sup>3</sup> H S Patil<sup>4</sup>

1. Associate Professor & Head, Civil Dept., Charotar Institute of Technology, CHARUSAT, Changa.

2. Lecturer, Civil Department, Charotar Institute of Technology, CHARUSAT, Changa.

3. Director, C G Patel Institute of Technology, Bardoli – 394 350.

4. Professor, Applied Mechanics Department, SV National Institute of Technology, Surat – 395 007.

[nirajshah.cv@ecchana.ac.in](mailto:nirajshah.cv@ecchana.ac.in)

**ABSTRACT-***Deflection theory is the basic theory of cable and stiffening girder suspension bridges. Geometric nonlinearity of suspension bridges due to dead load is taken in to account in this theory. Geometrical changes are having significant effects in suspension bridges, so it cannot be neglected in preliminary analysis of suspension bridges. Series method is a new method for the deterministic aerostatic stability analysis of suspension bridges. The geometric nonlinearity in the deflection theory and the three components of displacement-dependent wind loads are taken into account in the method. A computer program for calculating change in various geometric parameters of stiffened suspension bridges is developed using HTML. Again another computer program for finding a critical wind velocity of suspension bridges was developed using MATLAB.*

## KEY WORDS

Aerostatic Stability, Suspension Bridge, Nonlinearity, Displacement Dependent Wind Load

## 1. INTRODUCTION

The basic design of a suspension bridge has been in use for centuries: thousands of years ago, people crossed waterways and chasms by swinging hand over hand on suspended cables. Later, walkways were hung from the cables to make the process easier, and the original vines and ropes began to be replaced with chains. Major bridges were still built using a truss design until 1808, when an American inventor named James Finley filed a patent on an early version of a suspension bridge. Finley's design involved stretching two strong chains over the top of several towers and anchoring them on either side of the bridge. He hung lesser chains from the two master chains and used them to suspend a rigid deck, and the modern incarnation of the suspension bridge was born.

A suspension bridge is a type of bridge which is built by suspending the roadway from cables attached to a master cable which runs above the length of the bridge. In addition to being

strong and lightweight, suspension bridges are also beautiful, and some of the most famous bridges in the world are also suspension bridges, including San Francisco's iconic Golden Gate Bridge and New York's Brooklyn Bridge. The design of a suspension bridge is simple and straightforward, and takes advantage of several techniques to distribute the weight of the bridge safely and evenly.

Suspension Bridges have received more attention due to their ability to cover the large spans. For bridging the long and unsupported spans, the Suspension Bridges present the most elegant and efficient structural solution. And hence, they are increasingly being constructed all over the world. Thus, there is a need for developing a comprehensive understanding about the detailed behavior of these bridges. Also, they are one of the costliest civil engineering projects, and hence necessitate much attention while its analysis and structural design stage. Therefore, it is imperative that a reliable analysis should be available. With the increasing central span length of suspension bridges, it becomes especially important to understand the aerostatic behavior of suspension bridges.

## 2. THEORY OF STIFFENED SUSPENSION BRIDGES & VERIFICATION

In the theory of cable and stiffening girder systems the geometrical relations between the positions and dimensions of a given element of the cable in the initial and deflected configuration is taken in to account. As shown in Fig. 1 an element of cable length is defined by  $cd$  subtends a length  $ab$  when not deflected. After deflection the point  $c$  and  $d$  move to new position  $c'$  and the length  $c'd'$  is in general not equal to  $cd$ . The vertical deflection of  $c$  is denoted by  $\eta$  and the lateral shift of the same point is  $\xi$ . The suspenders which connect  $cd$  to  $ef$  in the initial configuration, are attached to  $c'd'$  in the deflected position since  $c'$  and  $d'$  are the new positions of  $c$  and  $d$ . The deflection of the girder at  $e$  is denoted by  $v$  and is equal to the sum of  $\eta$  and changes due to the suspenders.

Structural details decide whether g shall be vertically below e and are discussed later. The slope of the undeflected cable is  $\Psi$ .

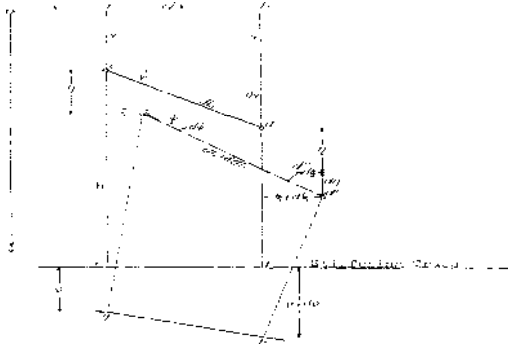

**Fig. 1: Cable Element**

Equations for calculating deflection of suspended main cable, deflection of girder, slope of undeflected cable in initial position and forces in suspenders of any finite element cable based on basic deflection theory of suspension bridges are as follows:

Lateral shift of cable element:

$$\xi = \left(1 - \frac{Hw}{EA} \sec Q\right) \left(\frac{4a_2 f}{l}\right) * \left\{ (1 - 2z) \sin 2\pi z + \frac{(1 - \cos 2\pi z)}{2} \right\} \quad (1)$$

Vertical deflection of cable element:

$$\eta = a_2 \sin 2\pi z \quad (2)$$

Initial slope of undeflected cable:

$$\Psi = \tan^{-1} \left( \frac{4f}{l} (1 - 2z) \right) \quad (3)$$

Deflection of stiffening girder:

$$v = a_2 \sin 2\pi z \quad (4)$$

Forces in the suspenders:

$$F_h = \left\{ \left[ \frac{Hw}{EA} \left[ \frac{8f}{l^2} + \frac{4\pi^2}{l^2} a_2 \sin \frac{2\pi x}{l} \right] \right] * \{h_s\} \right\} - \left\{ (h_s) * \left( \frac{w_1}{2} \right) \right\} \quad (5)$$

Horizontal component due to dead load:

$$H_w = \frac{wl^2}{8f} \quad (6)$$

Where,

E=Modulus of elasticity of cable, A=Area of cable, f=Sag of the cable, a<sub>2</sub>=Maximum deflection of structure, l= Length of

main span, h<sub>s</sub>=Hanger spacing, w= weight of main span, w<sub>1</sub>= weight of cables, suspenders etc. in main span

JavaScript is an object-oriented scripting language used to enable programmatic access to objects within both the client application and other applications. It is primarily used in the form of client-side JavaScript, implemented as an integrated component of the web browser, allowing the development of enhanced user interfaces and dynamic websites. JavaScript is a dialect of the ECMA Script standard and is characterized as a dynamic, weakly typed, prototype-based language with first-class functions. JavaScript was influenced by many languages and was designed to look like Java, but to be easier for non-programmers to work with.

A computer HTML program is developed for calculating change in various geometrical parameters due to dead load of Stiffened Suspension Bridges. Main feature of program is, it can simulate graphical presentation of deflected shape. Its accuracy has been checked by numerical example.

Properties of the main span of the Golden Gate Bridge at San Francisco are as under:

Length of Main Span= 4,200 ft., Sag of Main Span= 470 ft., Length of Side Spans= 1,125 ft., Weight of Main Span per lineal ft. Deck= 1,11,300 lbs., Weight of Cables, Suspenders etc.= 6,670 lbs., Weight of Stiffening Trusses= 3,330 lbs., Weight of Bracing= 600 lbs., Weight of Miscellaneous= 400 lbs., Total Weight =21,300lbs., Dead load for side spans per linear ft.= 21,500 lbs., Live load capacity per linear ft.= 4,000 lbs., Maximum downward deflection of Main Span= 10.8 ft., Longitudinal Tower deflections Shoreward= 22 ins., Longitudinal Tower deflections Channel ward= 18 ins., Diameter of Cables over wrapping= 36-f ins., Length of one cable= 7,650 ft., Number of wires in each cable= 27,572, Size of wire, diameter= 0.196 ins., Weight of cable, suspenders etc.= 24,500 tons., Moment of Inertia of one main stiffening girder= 43,150 in<sup>4</sup>.

## STIFFENED SUSPENSION BRIDGE

Length of main span - l (ft)

Weight of Main Span - w (ton)

Sag of the cable - f (ft)

Area of cable - A (inch<sup>2</sup>)

Diameter of cable - d (inch)

Modulus of Elasticity of cable - E (MPa)  \* 10<sup>5</sup>

Maximum deflection of a structure - a<sub>2</sub> (ft)

Hanger spacing (ft)

Weight of cable, suspenders, etc. (ton)

Steps of z

Vertical Cable Deflection			Girder Deflection				
Paper Results:[2]		Our Results		Paper Results:[2]		Our Results	
z	$\Psi$	z	$\tan(\Psi)$	$\Psi$	z	$\sin(2\pi z)$	$\eta$
0	24°7'	0	0.4476	24°7'	0	0.0000	0.0000
0.1	19°42'	0.1	0.3581	19°42'	0.1	0.5878	5.8779
0.2	15°2'	0.2	0.2686	15°2'	0.2	0.9511	9.5106
0.3	10°9'	0.3	0.1790	10°9'	0.3	0.9511	9.5106
0.4	5°7'	0.4	0.0895	5°7'	0.4	0.5878	5.8779
0.5	0°0'	0.5	0.0000	0°0'	0.5	0.0000	0.0000
0.6	5°7'	0.6	-0.0895	5°7'	0.6	-0.5878	-5.8779
0.7	10°9'	0.7	-0.1790	10°9'	0.7	-0.9511	-9.5106
0.8	15°2'	0.8	-0.2686	15°2'	0.8	-0.9511	-9.5106
0.9	19°42'	0.9	-0.3581	19°42'	0.9	-0.5878	-5.8779
1.0	24°7'	1	-0.4476	24°7'	1	-0.0000	-0.0000

### 3. AEROSTATIC ANALYSIS

Bridges are frequently built on exposed sites and are subject to severe wind conditions. Aerostatic loads on bridge superstructures depend on the type of bridge, such as slab-stringer, truss, arch, cable-stayed, or suspension. Other parameters that affect aerostatic loads on bridge superstructures are the wind velocity, angle of attack, the

size and shape of the bridge, the terrain, and the gust characteristics. Aerostatic loads form a major component of lateral loads that act on all structure. In general, they are a component of the so called environmental loads to which all structures are subjected. Because of the long spans, suspension bridges have become increasingly sensitive to aerostatic instability. On the other hand, experimental observations suggest that the aerostatic instability of long-span bridges (suspension bridges and cable-stayed bridges) can occur under the action of static aerostatic loads. Therefore, the aerostatic stability analysis of long span suspension bridges under the aerostatic loads is of considerable importance.

### 4. DETERMINISTIC AEROSTATIC STABILITY ANALYSIS OF SUSPENSION BRIDGES

A series method is proposed by Jin Cheng, Jian-Jing Jiang, Ru-Cheng Xiao [10] to overcome drawbacks of existing deterministic methods for aerostatic stability analysis of suspension bridges. Series method is also proposed to investigate the aerostatic stability of suspension bridges using a hybrid method, consisting of the series method and direct Monte Carlo simulation. Presented series method contains the following characteristics:

1. The series method considers both three components of displacement-dependent wind loads and geometric nonlinearity of structure in the deflection theory of suspension bridges.
2. The following derivation of formula is based on the deflection theory of suspension bridges.

This is mainly because this theory can, to a certain extent account for the geometric nonlinearity of structure (the stiffening effect of the tension force in the cable). This conclusion has been demonstrated by the fact that the majority of the existing long span suspension bridges were correctly designed using the deflection theory before the computer era.

### 5. ASSUMPTIONS MADE IN THEORY

In the above theory, the following assumptions are made:

1. Hanger is densely distributed along the bridge length direction;
2. The stretching of hangers under wind loads is ignored;
3. Changes of critical wind velocity caused by longitudinal deformation and lateral deflection of stiffened girder are ignored;



4. Configuration of cable during on completion is quadratic parabola; stress of stiffened girder due to dead load is ignored and
5. Under the action of drag force of displacement-dependent wind loads, the load transferred to the stiffened girder from cables is assumed to be isosceles triangle distribution.

## 6. SERIES METHOD

The series method is a two-step process: the calculation of deflection response under the displacement-dependent wind loads and the calculation of the critical wind velocity. The response under the displacement-dependent wind loads is calculated from Fourier series. The critical wind velocity is calculated by means of an iterative method. It is found that a small number of iteration cycles and Fourier coefficients are sufficient enough for convergence. The series method is suitable for single-span suspension bridges.

## 7. Three components of wind loads

The three components of wind load are drag force, lift force and pitch moment. Consider a section of bridge deck in a smooth flow, as shown in Fig. 2. Assuming that under the effect of the mean wind velocity  $V$  with the angle of incidence  $\alpha_0$ , the torsional displacement of deck is  $\theta$ . Then the effective wind angle of attack is  $\alpha = \alpha_0 + \theta$ . The components of wind forces per unit span acting on the deformed deck can be written in wind axes as:

$$\text{Drag force: } F_x(\alpha) = 0.5 \rho V^2 C_x(\alpha) D \quad (7)$$

$$\text{Lift force: } F_z(\alpha) = 0.5 \rho V^2 C_z(\alpha) D \quad (8)$$

$$\text{Pitch moment: } M(\alpha) = 0.5 \rho V^2 C_m(\alpha) B^2 \quad (9)$$

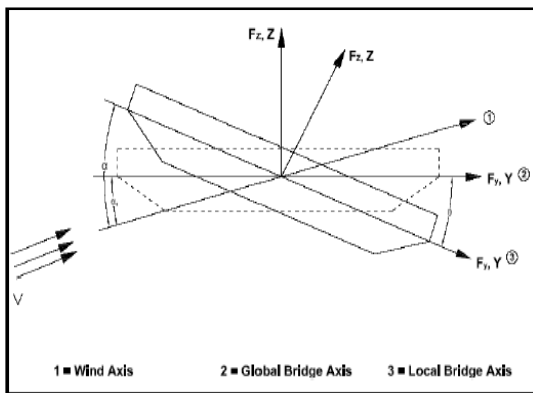

**Fig 2: THREE COMPONENTS OF WIND LOADS IN DIFFERENT AXES**

## 8. SOLUTION PROCEDURE

1. Calculate the initial horizontal component of cable tension owing to dead loads of cables, hangers and stiffened girder from

$$H_0 = \frac{ql^2}{8f}$$

2. Give an initial wind velocity  $V$
3. Initialize the iteration counter  $i = 1$ .
4. If  $i = 1$ , the coefficient  $b_{ri} = 0$ ,  $H_{pi} = 0$ , and  $H_i = H_0$  in Eq. (13).
5. Determine the coefficient  $a_{ri}$  by substituting  $b_{ri}$ ,  $H_{pi}$  and  $H_i$  into Eq. (13).
6. Calculate the vertical displacement of stiffened girder,  $\eta(x)$ , from (10).
7. Set  $i = i + 1$ .
8. Substitute  $\eta(x)$  into (9), and the new value of  $H_{pi}$  is determined.
9. Let  $H_i = H_0 + H_{pi}$
10. Substitute  $H_i$  into (7), and the coefficient  $b_{ri}$  is determined.
11. Calculate the torsional displacement of stiffened girder,  $\alpha(x)$ , and the vertical displacement of stiffened girder,  $\eta(x)$ , and the lateral displacement of stiffened girder,  $u(x)$ , from (4), (10), (18) and (19), respectively.
12. Check the convergence value  $\epsilon_1$  using

$$\epsilon_1 = \left| \frac{H^i - H^{i-1}}{H^{i-1}} \right|$$

13. If  $\epsilon_1 > \epsilon_{1max}$ , go to step 5. If  $\epsilon_1 < \epsilon_{1max}$ , continue.
14. Check the convergence using
15. Check if  $H^i$  has a negative value.
16. If  $H_i$  is a positive value, update the wind velocity  $V$  using
17.  $V = V + \Delta V$
18. Where  $V$  is the incremental wind velocity, go to step 2;

	m (t/m)	E(MPa)	$\gamma$
Steel box girder	18.33	210000.0	0.3
Cable	2.397	200000.0	-
Hanger	0.172	160000.0	-

19. Otherwise, STOP (end of calculation).

The flowchart for the same is as shown in Fig. 3.

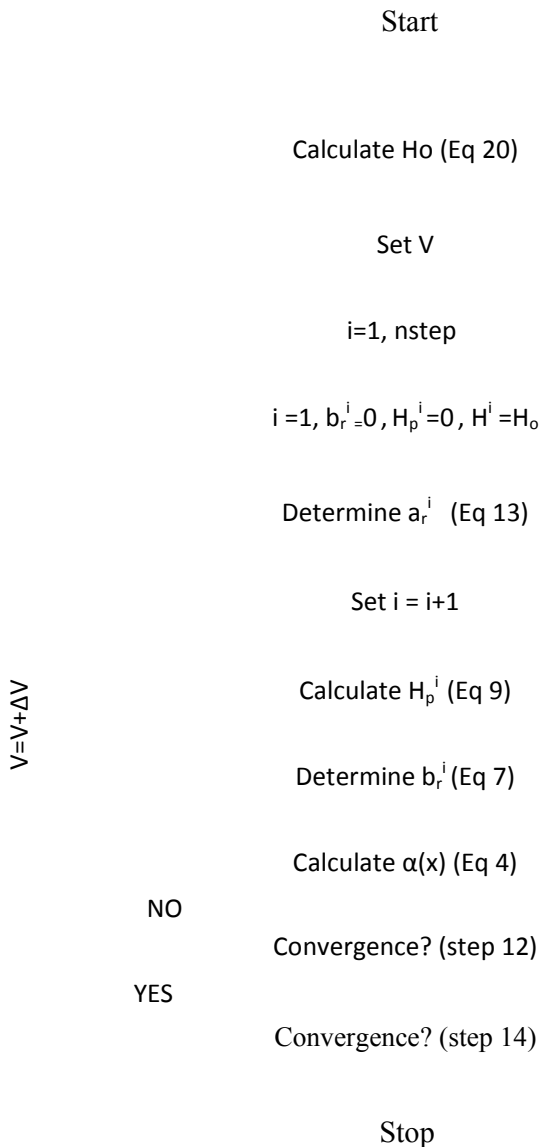

**Fig 3: FLOW CHART FOR SOLUTION PROCEDURE**

**9. VERIFICATION EXAMPLE**

The Hu Men suspension bridge in China was chosen for verification example. The general configurations of the bridge, shown in Fig. 5.03, are summarized as follows: a suspension bridge of main span 888 m; portal frame shape towers with 150 m height; closed-box deck with 3.012 m depth and 35.6 m width; width between center lines of cables is 33 m; the spacing between the two hangers is 12.0 m. section material and geometrical features of the main member are indicated in Table 1.

**Table 1: SECTION GEOMETRICAL AND MATERIAL FEATURES**

The three components of the displacement-dependent wind loads were only considered for the bridge deck while for the cables only the initial drag force was considered. The angle of incidence  $\alpha_0=0$  is taken. The coefficients ( $e_1, e_2, c_1, c_2$ ) are given by  $e_1 = 0.00877, e_2 = 0.01838, c_1 = 0.02462, c_2 = 0.0789$ . Sag of the cable is 143 m. Drag force acting on the towers was not considered.

Comparison of different methods result for critical wind velocity is shown in table 4.02. From this table it can be seen that presented series method result using matlab-7.0 is nearly equal to paper result. And quite satisfactory result in the prediction of critical wind velocity can be obtained by using MATLAB program. And <5% difference with respect to accurate critical wind velocity calculated by different methods as shown in Table 2.

Fig 4 shows horizontal tension in cable vs. wind velocity. From this fig it can be seen that horizontal tension in cable decreases with increase in wind velocity. And for a particular wind velocity it gives negative value. It indicates critical wind velocity, which may causes instability in suspension bridge.

**Table 2: RESULT COMPARISON FOR CRITICAL WIND VELOCITY**

	PAPER RESULT			MATLAB-7.0 RESULT
	NFE M	LINEAR METHOD	SERIES METHOD	SERIES METHOD
Critical Wind Velocity (m/s)	120.0	136.0	125.0	123.0

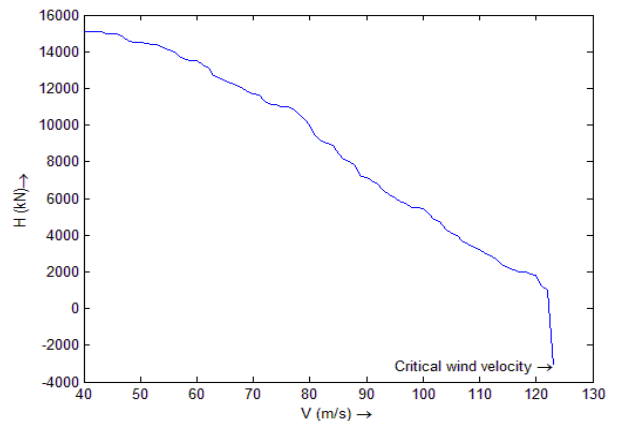

**Fig 4: HORIZONTAL TENSION VS. WIND VELOCITY**

## 10. Conclusions

From this work following conclusions can be drawn:

1. Series method gives very precise results compared to NFEM and linear method, the difference is @ <5% with respect to accurate critical wind velocity. Hence, series method is suggested for higher spans.
2. The results show that the developed program is accurate, practical, and computationally efficient.
3. By using series method, the problem of aerostatic analysis is greatly simplified, thus saving of computation time significantly.
4. Vertical deflection and lateral shift of main cable element is having significant effect in deflected configuration of stiffened suspension bridges.
5. To determine longitudinal movement of the girder, due to the inclination of the suspenders it is necessary to know the forces in the suspenders.
6. Salient feature of HTML program is, it can simulate deflected shape of a cable element at various distances from tower.

## 11. References

1. B. Semper "A Mathematical Model Suspension Bridge Vibration", Math1. Computer Modeling, Vol. 18, No. 11, pp. 17-28, 1993.

2. Dino A. Morelli "Some Contribution To The Theory Of The Stiffened Suspension Bridges"
3. E.S. Kreis, J.C. Andr "A Numerical Inquiry into The Flutter Phenomenon in Long-span Bridges", Latin American Journal of Solids and Structures, 2 (2005) 321–337
4. Haifan Xiang, Yaojun Ge "Refinements on Aerodynamic Stability analysis of Super Long-span Bridges" Journal of Wind Engineering and Aerodynamics, Elsevier, 90 (2002) 1493–1515,
5. H. Erdogan, E. Gulal "The Application of Time series analysis to Describe the Tynamic Movements of Suspension Bridges", Elsevier , Nonlinear Analysis: Real World Applications 10 (2009) 910–927.
6. Henrik Ditlev Nissen, Paul Haase Sorensen.and Ole Jannerup "Active Aerodynamic Stabilisation of Long Suspension Bridges", Elsevier , Journal of Wind Engineering and Industrial Aerodynamics 92 (2004) 829–847.
7. Jin Cheng, Jian-Jing Jiang.and Ru-Cheng Xiao, Hai-Fan Xiang "Nonlinear Aerostatic Stability analysis of Jiang Yin Suspension Bridge", Elsevier , Engineering Structures 24 (2002) 773–781.
8. Jin Cheng, Ru-cheng Xiao "Probabilistic Free Vibration and Flutter analyses of Suspension Bridges", Elsevier, Engineering Structures 27 (2005) 1509–1518.

# Flooding in Computer Network With Passive Clustering

Darshana Mistry

Computer Engineering Dept., Gandhinagar Institute Of Technology,  
Ahmedabad, India  
Darshana.mistry@git.org.in

**Abstract**— An ad hoc network is a fast deployable self configuring wireless network characterized by node mobility, dynamic topology structure, unreliable media and limited power supply. Nodes in an ad hoc network must cooperate and carry out a distributed routing protocol in order to make multi-hop communications possible. On Demand Routing is one of the most popular routing styles in ad hoc networks. In On Demand Routing, "flooding" is used to find a feasible route from source to destination. The function of flooding is to deliver a packet from one source to every other node in the system. Conventional flooding can be very costly in On Demand networks in terms of network throughput efficiency as well as node energy consumption. The main reason is that the same packet is rebroadcast unnecessarily several times (redundant rebroadcast). Indeed, the penalty of redundant rebroadcast increases when the size of network grows and the density of network increases. In this paper we introduce a novel clustering scheme, call Passive Clustering that can reduce the redundant rebroadcast effect in flooding.

**Keywords**-Flooding, Passive Computing

## I. FLOODING IN COMPUTER NETWORKS

Flooding is a packet dissemination procedure by which every incoming packet at a node is sent out on every outgoing link except the one it arrived on. In a wireless environment, the physical exclusion of the arriving link is impossible. Since the media is broadcast, a single relay of a flooding packet fulfils the task if the broadcasting is successful, i.e., all neighbors receive the packet. Unfortunately, some of the neighbors may not receive the packet due to many reasons including noise, receivers' status, mobility, collision etc. Since every neighbor that has received the packet will rebroadcast it, flooding can generate an infinite number of duplicate packets if there is no control mechanism. One of the mechanisms for prohibiting infinite duplication is tracking flooding packets. Duplicates are detected (from a unique source identifier and a sequence number, for example) by each receiving node and are immediately discarded in order to avoid endless looping. Another control mechanism is Time-to-Live (TTL). A flooding packet carries

a TTL field which represents the maximum hop that the packet can traverse. Upon reception of a flooding packet, the receiving node checks the TTL field and determines whether the packet will be rebroadcasted (after decreasing TTL) or dropped. Path logging in a flooding packet can also be a controlling mechanism. By carrying a list of nodes that a flooding packet has visited, a node can easily avoid looping by examining its ID in the list. If there is a match, the node drops the "returning" packet. In spite of the control mechanisms listed above, flooding generates replicated packet arrivals to each node; namely, one replica for each neighbor. Thus, flooding overhead corresponding to replicated, redundant packets increases with connectivity. Flood search is the capstone of all on-demand rough and multicast protocols. These protocols need to find a path on demand. Since one generally assumes that there is no underlying routing or relative geographical positioning infrastructure that can guide the packet to destination, a path search query must be flooded to the entire network, or at least through a certain section (scope) of it. Once the path search query packet reaches a destination by flooding, the destination can report a path to the source as a reverse path through which the search packet came. Or the destination can report the path to the source with another flooding in case there are asymmetric links. AODV (Ad hoc On-demand Distance Vector routing [1]), for example, uses seeded flooding to find a route. By tagging "Time To Live (TTL)" on each Route-Request flooding packet, a source gradually enlarges flood search diameters. On the other hand, DSR depends on complete flooding to the entire network if a source cannot find a path to destination in a single hop. If the communication patterns are "local", scoped flooding is effective. On the other hand, if destinations typically many hops away, it would be wasteful to run the incremental scoped flooding.

## II. EFFICIENT FLOODING

Generally speaking, flooding in ad hoc networks is used to find a feasible route to a destination or to advertise routing information. If the network is dense, it is not necessary for every node to relay the flood search packet. In fact, it may suffice to use only a subset of nodes as relays. There are many ways to reduce the number of forwarding participants. All of the approaches concern selecting the dominant set, i.e.,

a minimal subset of forwarding nodes which is sufficient to deliver the flooding packet to every other node in the system. There are two basic approaches for selecting the dominant set: without and with a clustering structure. The first approach (no clustering) includes the building of a source tree with the maximal number of leaf nodes and the building of a well covered mesh [6,7]. By excluding leaf nodes from forwarding participation, the method can improve flooding efficiency. To build such source tree, two hop connectivity information is necessary. To collect the required information, at least two complete floorings from a source are necessary. The first flooding (which can be replaced with well-coordinated hello messages) is to learn the one-hop neighbors. The second flooding is to report the direct (one-hop) neighbor lists. By collecting the complete neighbor lists of all of its neighbors, a node can construct the two-hop connectivity, i.e., the list of nodes that are two hops away. From this list, each node selects the minimum set of one-hop neighbors which cover all the downstream two-hop neighbors. This problem can be reduced to the well-known "set-cover" problem (NP-complete). Starting from a source and applying this procedure recursively one generates the non-leaf nodes of a minimal flooding tree. Span and GAF build their dominant set as a well-covered mesh. Span selects nodes that are potentially on critical paths as coordinators, i.e. members of a dominant set. GAF partitions the region with a grid such that any nodes in neighboring cells can communicate each other; one node per cell is selected to form the dominant set. The complexity of the selection algorithm in this category is dependent on the number of neighbors (except for GAF which requires GPS information instead). In other words, complete neighbor list knowledge is always the assumption. Note that the neighbor-learning procedure is not trivial in ad hoc networks and it involves substantial overhead with high node density and mobility. The second approach is based on a two-hop clustering structure. To illustrate this concept, let us consider the n node example in Figure 1. Let r be a transmission range, and the size of the roaming space be  $((k/\sqrt{2})r) * ((k/\sqrt{2})r)$  where k is an even number (Figure 1 depicts the case of k = 6). There are n nodes in the square, but in the figure we only show the nodes at coordinates  $((a/\sqrt{2})r, ((a/\sqrt{2})r))$  where either a or b is an integer smaller than k. This "selection" of nodes is known as "two hop clustering", ie, any two nodes in a cluster are separated by at most two hops. The nodes at the center of the circles are "cluster heads" and the light-shaded nodes in between are "gateways." Clearly, such nodes represent a connected set. They are in fact the dominant set required to forward the flood packets. Without the cluster overlay shown in Figure 1, each flood packet is relayed exactly n-1 times, as each node must rebroadcast the packet once. On the other hand,

$$(k-1)*k/2+k/2(k/2-1)=(k*(3*k-4))/4$$

broadcasts suffice if only cluster heads and gateways forward the packet. Note that in the cluster restricted forwarding, ALL nodes still receive the flood packet. The flooding reduction is thus  $((k*(3*k-4))/4)/(n-1)$  In case of n = 100

and k=6, the number of broadcasts required in the cluster is 21 instead of 99. In other words, 78.8% of transmissions can be saved. This is not even a very dense network (each node has about 12 neighbors). As we increase the number of nodes in the system (and therefore the density), the clustering structure and thus the broadcast remains the same. As a result, the saving increases with the node density,

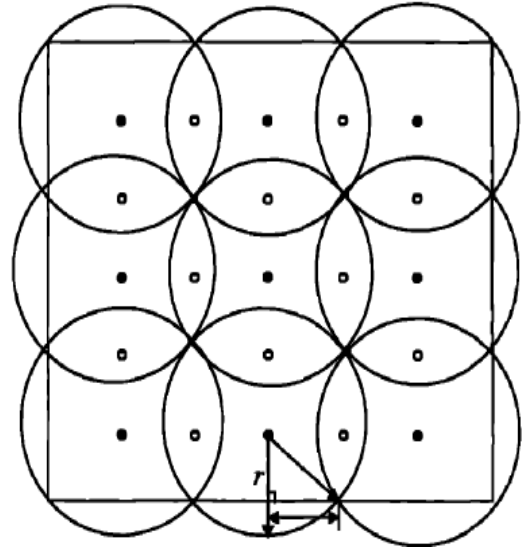

Figure 1. Selective Gateway Flooding Scenario

### III. CLUSTERING IN AD HOC NETWORKS

In the previous section we showed that clustering is one of the key approaches to flood overhead reduction. In this section, we elaborate on this important concept. Clustering in wireless ad hoc networks has been investigated in the past in order to enhance network manageability, channel efficiency, and energy economy. Moreover, clustering is indispensable for hierarchical routing or multicasting[2]. However, the clustering schemes proposed so far in the literature are "active". They require a constant refresh rate of cluster-dependent information, and therefore introduce significant background control overhead even if there is no data to send in the network. In some applications, for example, covert military operations and sensor networks, this periodic control traffic is highly undesirable. The penalty introduced by the control traffic (eg, exposure to enemy interception, power consumption, etc) may offset the benefits offered by clustering. Clustering in ad hoc networks can be informally defined as *grouping of nodes into a manageable set*. Many prior research efforts carried out clustering in different ways. Such efforts started with the DARPA packet-radio network. As a result, the network was dynamically organized into clusters similar to the cluster structure shown in fig. 1.

Several clustering mechanisms have been proposed in the literature. The schemes reported in all lead to similar structures (overlapping two-hop clusters with cluster heads). The schemes in partition the network into disjoint sets of clusters. All of these clustering mechanisms assume prior knowledge of the full neighbor list, or they periodically monitor neighbor information by exchanging explicit control

packets. This topology learning overhead is significant if the number of neighbors is large and the topology is dynamic. None of these schemes will work properly with only partial neighbor information. An important subclass implements two-hop clustering. Two-hop clustering requires that every node in a cluster be reached from another node in the same cluster with at most two hops. Two-hop cluster is a natural clustering structure in ad hoc networks. It only requires direct neighbor information and is easy to construct. The cluster structure in Figure 1 is an example of a two-hop cluster structure. Two-hop clustering has the following properties:

- There is a cluster head at the center of a cluster, and the cluster head can communicate with any node in the cluster with a single hop.
- No cluster heads are directly linked.
- Any two nodes in a cluster are at most two hops away. Two-hop clustering ends up with a structure similar to the cellular system. There are cluster heads at the center of each cluster (a useful by-product). Nodes belonging to more than one cluster are gateways. The rest of the nodes are ordinary nodes.

#### *A.Limitation of Existing (Active) Clustering Scheme*

Most clustering algorithms in the past have been studied via simulation and have used the complete neighborhood information. Unlike the simulation environment, accurate global information regarding node locations and adjacency relations is hard to collect in an actual wireless ad hoc network implementation, especially when the node density is high. The major difficulties stem from unreliable and limited link capacity, and from node mobility. Node locations and neighborhood information are key for clustering; unfortunately, they do vary in time. Without the help of a special node – say "oracle" which can listen or talk to all the nodes at the same time - adjacency (neighborhood) information can only be collected by exchanging beacons or hello messages. In this neighbor learning process, no mobility is generally assumed. To ensure the correct collection of neighborhood information, existing clustering solutions rely on periodic broadcast of the neighbor list. In the period of neighbor learning and initial clustering, it is essential that there is no mobility for proper convergence. The quasi-stationary assumption must hold during the adjacency information collecting period, initial clustering, and the re-clustering or clustering maintenance period. If there is motion, we may have to deal with stale neighborhood information during the neighbor learning period. Moreover, mobility causes adjacency relations to change, which in turn may trigger re-clustering throughout the network. Other drawbacks including isolation (structural disconnection), etc., are listed and explained in.

## IV. PASSIVE CLUSTERING

In this section, we introduce a new cluster formation protocol that is free from the periodic overhead and other limitations discussed in the previous section. This novel approach not only overcomes many limitations of existing clustering mechanisms, but also improves performance and yields new features. Here, we present the concept of passive clustering and illustrate its operation by example. The proof of its correct operation and the detailed description can be found in.

### *A.Protocol Overview*

Passive Clustering is a cluster formation protocol that does not use dedicated protocol-specific control packets or signals. Conventional clustering algorithms[2], as earlier discussed, require all of the participating network nodes to advertise cluster dependent information repeatedly. Moreover, most of the existing clustering schemes require the execution of a separate clustering phase prior to any network layer activity (e.g., routing). With passive clustering, we avoid all the above limitations. By monitoring user data packets that piggyback some predefined cluster information, we can build impromptu "soft state" clusters for mobile wireless networks. Thus, the cluster infrastructure can be constructed as a by-product of user traffic, without any dependency on the routing protocol, for example. In passive clustering, each node collects neighbor information from the MAC sender address carried by the incoming packets, and can construct clusters even without collecting the complete neighbor list. This is an innovative approach to clustering which virtually eliminates major cluster overheads - the time latency for initial clustering construction as well as the communication overhead for neighbor information exchanges. Instead of using protocol specific signals or packets, cluster status information (2 bits for four states: Initial, Cluster head, Gateway, and Ordinary-node states) of a sender is stamped in a reserved field in the packet header. Sender ID (another key piece of information for clustering) is carried by all the existing MAC protocols and can be retrieved from the MAC header. Since in flooding the MAC packets are transmitted in broadcast (instead of unicast mode, every node receives and reads the packets (in a promiscuous way), and thus participates in passive clustering. Note: you cannot perform flooding at the MAC layer because you need to detect duplicates (reading, for example, flood originator ID number which is stored in the packet, not MAC, header). Since passive clustering relies on flooding packets, it may as well be done at the packet layer. Surprisingly, simulation results show that passive clustering can form better clusters than conventional clustering schemes based on eight (i.e., ID, degree, etc.) information. This is because passive clustering (as used in the support of ad hoc muting schemes) uses network traffic that emanates from sources (i.e., the source in search of a path). If a cluster structure is constructed by a flooding from a single source, the resulting structure is completely immune from logical isolation and lack of connectivity. Clustering stability and fast convergence time are other important properties required of clustering

algorithms. To improve clustering stability and speed up convergence, and most importantly, to avoid the "stationary" requirement during the neighbor-learning and clustering phase, we developed a new cluster head election rule which does not require any weight information. We call this rule "first declaration wins." With the first declaration wins rule, a node which first claims to be the cluster head remains the cluster head and "rules" the rest of nodes in its clustered area (radio coverage). There is no waiting period (to make sure all the neighbors have been checked) unlike in all the weight-driven clustering mechanisms.

### B. Operational Description

When a node is ready to become a cluster head and has packets to send, it declares that it is a cluster head by stamping its clustering state claim in the packets. Since passive clustering does not support explicit control packets or signals of its own, a cluster head-ready node must postpone its claim until it has outgoing "application" packet level traffic, for example, flood search packet traffic. After a successful transmission from an aspiring cluster head, every node within radio coverage learns the presence of the cluster head by monitoring the "cluster" state of the received packets. At this point, the neighbors of the cluster head record the cluster head information (cluster head ID and the most recent transaction time-timestamp) and change their clustering states as discussed below. The readiness of being a cluster head is determined by network activities as well as by the node's clustering state. After a period of inactivity (i.e., no incoming or outgoing traffic for longer than the cluster timeout period), all the nodes revert to the INITIAL state. Only nodes in INITIAL state can be cluster head candidates - in other words, two hop is the minimum distance between any two cluster heads since all neighbors of a declared cluster head exit the INITIAL state. After a cluster head successfully asserts its state, it functions as a cluster head. Cluster heads collect neighbor information by monitoring the network traffic. They are responsible for relaying intra cluster packets. A node that hears more than one cluster head becomes a GATEWAY. It reverts to ORDINARY node if it does not hear from more than one cluster head for a given period. In the next section we will describe a slightly modified procedure (selective gateway) in which a part of gateways in this definition also reverts to ordinary node upon hearing a certain number of other gateways. A node that is neither a cluster head nor a gateway is an ordinary node. The ordinary node does not forward flooding packets. It is precisely this forward-suppression mechanism that reduces flood overhead. Gateway nodes and cluster heads, on the other hand, will keep forwarding the flood packets. Because of the passive nature of the collection mechanism, neighbor information is kept in soft state and is possibly incomplete. Note here again that complete neighbor information is no longer necessary to form the structure. By using timestamps for neighbor information, we preserve the freshness of the information. Ordinary nodes and gateways keep a list of their cluster head(s) in soft states. The time, out period has to be carefully chosen based on node mobility and communication pattern.

Non-cluster head nodes can collect their own cluster head(s) information in a passive way. If a received packet is from a cluster head (after checking the status information in the packet), non-cluster head nodes compare the sender ID of the packet with their own cluster head list and add or refresh accordingly.

## V. SELECTIVE GATEWAY PASSIVE CLUSTERING

In typical examples implementing the above basic scheme, one quickly discovers that the number of gateways is quite significant and is typically larger than that of ordinary nodes. Clearly, there is quite a bit of redundancy here, and not all of the gateways have to relay the flooding packets. It is mandatory to reduce the number of gateways in order to achieve efficient flood search packet suppression. Careful gateway selection is the natural solution to improving flooding efficiency. To select the strictly minimal set of gateways, we would need to collect the cluster head list for each gateway, and then choose one gateway for each pair of cluster heads. This is another set-cover problem and introduces extra communication and computation overhead since the procedure requires cluster head list exchanges between gateways. In order to avoid the communication and computation complexity, we introduce a heuristic solution to this problem in the following section.

### A. Gateway Selective Heuristic

Instead of selecting a single gateway between adjacent cluster heads (two-hops away), we developed a heuristic algorithm that enables a limited number of gateways, and at the same time, preserves adequate connectivity within the resulting cluster structure. The selection algorithm provides many advantages including on-the-fly flooding improvement, redundant connectivity, and higher overall flooding efficiency. The heuristic also allows "distributed gateway" implementations. Every non-cluster head node monitors and keeps track of the number of cluster heads (NC) and the number of gateways (NG) within range. Whenever a non-cluster head node hears a packet from a cluster head or a gateway, the node becomes a gateway if  $a \cdot NC + fl > NG$ , where  $a$  is a coefficient properly chosen based on the desired degree of gateway redundancy ( $a \geq 0$ ) and  $fl$  is a gateway redundancy factor ( $fl \geq 0$ ). Otherwise, the non-cluster head node becomes an ordinary node. The larger the number of cluster heads that a node can hear, the higher the chance to become a gateway. By manipulating  $a$ ,  $fl$ , we can control the number of gateways in the system. The larger the number of gateways, the lower the gain in forwarding overhead reduction. On the other hand, if there are too few gateways, connectivity may be impaired leading to a poor network performance. In this paper,  $a$  and  $fl$  are global system parameters and are both set to 1. The values of  $a$  and  $fl$  should be chosen based on considerations including channel quality, noise level, as well as traffic pattern. For that reason,  $a$  and  $fl$  can be local parameters, i.e., they can be locally adjusted to provide better adaptability and flexibility. In dense networks where packet collisions abound, higher values of those

parameters lead to more gateways and better network performance by distributing network traffic over more gateways. Conversely, in low density we suggest to keep the parameters low to discourage multiple gateway creation. By introducing these heuristic, passive clustering strikes a good balance between cluster heads and gateways and retains only a handful of forwarding nodes for flood search no matter how high the node density is. The gateway selection procedure is fully distributed, and requests only local information. No cluster head fist exchange is required.

### *B. Flooding Improvement on Fly*

Let us consider the example of single-source flooding from a cold start. Every node is in the Initial state, and a source broadcasts a Route Request packet. The immediate neighbors of the source receive the packet, and change their state to Cluster head-Ready. When one of the neighbors is ready to forward the packet, it changes its state to Cluster head, and broadcasts the Route Request packet with the Cluster head state assertion. This time, all the nodes including the source that receive the relayed Route Request packet from that newly proclaimed cluster head are eligible to become gateways since they have heard from one cluster head, and from no gateways (for simplicity, in this case we assume  $a = 1$  and  $p = 0$ .) Now, one of the gateways except the source may relay the flood search packet. This relay does not switch any gateways back to ordinary nodes because they still have the number of cluster heads ( $= 1$ ) which is equal to or smaller than the number of gateways (0 or 1). Let us say that a second gateway within range of the first declared gateway relays the flooding packet. Thereafter, none of

nodes in the intersection area of those two gateways can become a gateway - they turn into ordinary nodes after they receive the second flooding packet - their head count for cluster head equals 1 but they have already 2 gateways. One may notice that there is a chance of critical path loss with these heuristics. However, extensive simulation experiments have shown that the risk of flood delivery failure to certain areas of the network is negligible, even with moderate node density, if the coefficient  $a$  and the redundancy factor  $p$  are properly chosen. With additional assistance from the routing protocol, we can completely eliminate such "block out" areas.

### *C. Properties of Passive Cluster Solution*

It is appropriate at this point to compare and contrast passive clustering with traditional, lowest ID active clustering. We have already discussed the impact of the background updating procedure and the neighbor list broadcast requirements on the control traffic overhead caused by active clustering. Here we focus on the structure of the solutions. Typically, one finds that the two solutions are comparable (in terms of number and layout of clusters). Major differences are: (a) the fact that active clustering is carried out independently, in the background and in parallel across all nodes in the network, while passive clustering is "on-demand" and is initiated by a single "source", namely the first source that needs to send data. Thus, active clustering tends to lead to disconnected islands (which require the

"distributed gateway" feature- ie gateway to gateway links to reestablish connectivity). Passive clustering does not suffer from this problem (albeit it can also be extended to support distributed gateways) (b) the fact that passive clustering features the "selective gateway" provision. Popular active clustering schemes do not include such feature (c) the lowest ID feature tends to make the active clustering more sensitive to mobility - the cluster head can be more easily challenged by newcomers with lower ID Another important issue is the suitability of Passive Clustering for Low Energy operations, as in battlefield scenarios or sensor network applications. Repeated selection of the same subset of clusters and gateways can be detrimental to low power operation in that it creates uneven energy consumption. In this respect, passive clustering is beneficial. In fact it favors even distribution since at each new cluster formation round (caused by the arrival of a new user data session, say), new clusters and gateways are selected as the source changes and/or, even in the case of same source, the random timers cause different cluster-heads and gateways to assert their role first. In the case of "permanent" traffic pattern where the cluster structure tends to persist, a possible remedy is to associate the cluster-head and gateway status with a minimum energy level requirement. When energy drops below this threshold, the role is given up triggering a new election.

## VI. CONCLUSION

A passive new clustering algorithm for efficient flooding in ad hoc networks. For efficient flooding, we propose to superimpose an on demand cluster structure which can be quickly deployed in the "unstructured" ad hoc network, and let only non-ordinary nodes (cluster heads, gateways, "initial state" nodes) participate in the flooding process. Due to its passive nature, passive clustering does not introduce any control packets dedicated to the protocol. In other words, it is "control overhead free". Thus, it can reduce the cost of flood search significantly without producing any line overhead. Even better, there is no preparation time or overhead for selecting dominant sets. As the results, the number of flooding relays can be significantly reduced even during the first flooding. This is the unique feature and strongest advantage of the proposed mechanism. It is especially useful for ad hoc networks with high mobility. The gateway selection scheme is density-adaptive. Its efficiency increases linearly with the number of neighbors, ie, with node density. Beside assisting with flood reduction, the clustering structure offers several other side benefits. In particular, it can be beneficial to routing scalability, reliability and QoS support. Passive clustering is a self-sufficient clustering scheme. The protocol collects all the

necessary information itself and does not require costly information like global topology knowledge from the lower layer. The resulting cluster structure is superior to any existing clustering algorithm in terms of stability, mobility robustness and connectivity. Passive clustering can build the cluster structure with partial neighbor information which, in most cases, is the only possible information available in an ad hoc network.



## REFERENCES

- [1] Das S.R, Perkins C.E. and Royar E.M. "Performance comparance of Two On-demand Routing Protocols for Ad hoc Networks, In processing of IEE INFOCOM 2000, Tel Aviv, Isreal, March 200.
- [2] T. J. Kwon, M.Geria, "Efficient flooding with passive clustering(PC) in Ad hoc networks",ACM SIGCOMM,44-56.
- [3] K. Obraczka, K.Vishvanath, "Flooding for Reliable Multicast in Multi-Hop Ad hoc networks", Wireless networks,627-634, Kluwer Academic Publishers, 2001
- [4] J. Li, P.Mohapatra, "PANDA: A novel mechanisam for flooding based route discovery in ad hoc networks",Wireless networks (2006) 771-787.
- [5] V.Shurbanov, J.Redi, "Energy efficient flooding in Mobile Ad hoc networks"
- [6] Chen, B., Jamieson, K., Balakrishnan, H. and Morris, R., Span: An energy-efficient coordination algorithm for topology maintenance in Ad Hoc wireless *networks*, In Proceedings of ACM/IEEE MOBICOM 2001, Rome, Italy, 2001.
- [7] Xu, Y., Heidernann, J. and Estrin, D., *Geographyinformaed* Energy Conservation for Ad Hoc Routing..In Proceedings of ACM/rEi~ MOBICOM2001,

# ANN BASED INTELLIGENT CONTROLLERS FOR AN INDIRECT VECTOR CONTROLLED THREE-PHASE INDUCTION MOTOR

Ami Patel<sup>1</sup> \* Tejendra Pate<sup>2</sup>

1. Assistant Professor, MGITER, Navsari  
2. P.G. Student SVNIT, Surat  
43/B Alka Co. op. Hsg. Society, Chhapra road, Navsari,  
Pin code: 396445, (M): 1) 9724326517

[ami\\_engg86@yahoo.com](mailto:ami_engg86@yahoo.com)

[ami.mgiter@gmail.com](mailto:ami.mgiter@gmail.com)

**Abstract:**-Artificial Intelligent methods such as Fuzzy Logic control and Neural Network control have found high applications in most of the nonlinear systems like the electric motor drives. These Intelligent controllers can be used for any system without requirement of the system mathematical model unlike that of the conventional electrical drive control, which requires the mathematical model. Due to the usage of the FLC and Neural Network control concept, the efficiency, reliability & performance of the AC drives increases. This paper presents a Fuzzy logic and Neural network based speed controller and its design for vector controlled induction motor drive. These controllers have been implemented on 3 phase, 415 V, 5 HP squirrel cage induction motor. Test response for the developed schemes are given and discussed in detail.

**Key words:** Induction motor, Vector control, Fuzzy logic, Neural Network

## 1. Introduction:

Induction motors are widely used in industries due to its robust construction and low maintenance. Separately excited dc drives are simpler in control because independent control of flux and torque can be brought about. In contrast, induction motors involve a coordinated control of stator current magnitude and the phase, making it a complex control. The stator flux linkages can be resolved along any frame of reference. This requires the position of the flux linkages at every instant. Then the control of the ac machine is very similar to that of separately excited dc motor. Since this control involves field coordinates it is also called field oriented control. The requirement of the phase angle of the flux linkages in the control process gives the name vector control. [1]

Along with industrial progress high performance drives are essential. Recent advances in semiconductors, converters and new control techniques have great role in this progress. Usually classical control requires accurate mathematical model of the system and also its performance decreases for nonlinear system such as drives. Recently by adapting non linear speed control techniques the dynamic performance of electric drives can be improved.

This paper proposes implementation of fuzzy logic and Neural Network control scheme applied to model of Induction motor. Both the controllers are developed on MATLAB environment. The performance of Fuzzy logic controller and Neural Network controller is compared with that of classical controller in terms of rise time and steady state error. The developed control scheme was verified by simulation and the results obtained demonstrate the effectiveness of Intelligent controllers.

## 2. Indirect Vector control:

Indirect vector control method is very popular in industrial applications. The block diagram of VCIMD is shown in fig.1. The motor current is decomposed in two components  $i_{ds}$  and  $i_{qs}$ , direct and indirect axis current with respect to synchronously rotating reference frame. These current are responsible for producing flux and torque respectively. Here unit vector signals are generated in feed forward manner. This method uses indirect procedure to ensure presence of rotor flux in the direct axis. With the help of an intelligent controller, the speed error is converted into a torque controlling current component  $i_{qs}$ , of the stator current. This current component is used to regulate the torque along with the slip speed. [1]

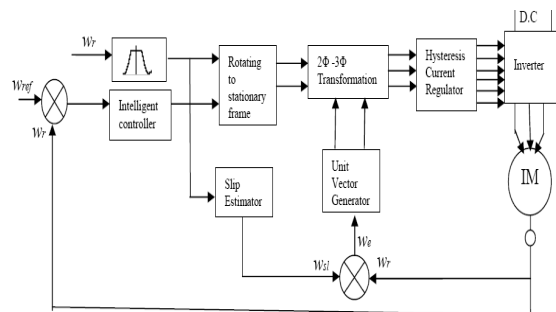

Fig.1 Block diagram of Indirect Vector control method

The following equations are necessary to implement vector control scheme.

$$\theta_e = \int (w_r + w_{sl}) \quad \text{----- (1)}$$

The rotor circuit equation can be written as,

$$\frac{d\Psi_{ar}}{dt} + R_r i_{ar} - (w_e - w_r) \Psi_{qr} = 0 \quad \text{----- (2)}$$

$$\frac{d\Psi_{qr}}{dt} + R_r i_{qr} + (w_e - w_r) \Psi_{qr} = 0 \quad \text{----- (3)}$$

For decoupling control,

$$\Psi_{qr} = 0$$

$$\frac{L_r}{R_r} \left( \frac{d\Psi_r}{dt} \right) + \Psi_r = L_m i_{ds} \quad \text{----- (4)}$$

The slip frequency can be calculated as,

$$w_{sl} = \frac{L_m R_r}{\Psi_r L_r} I_{qs} \quad \text{----- (5)}$$

$$\Psi_r = L_m i_{ds}$$

Thus, rotor flux is directly proportional to current  $i_{ds}$  in steady state. The motor developed torque is directly related to  $i_{qs}$  as follows:

$$T_e = \left( \frac{3}{2} \right) \left( \frac{P}{2} \right) \left( \frac{L_m}{L_r} \right) \Psi_r i_{qs} \quad \text{----- (6)}$$

$$i_{qs} = \left( \frac{4}{3P} \right) \left( \frac{L_r}{L_m} \right) \left( \frac{T_e}{\Psi_r} \right) \quad \text{----- (7)}$$

This current component is used to regulate the torque. [2]

### 3. Fuzzy Logic speed controller Principle and Design:

Basic structure of the fuzzy logic controller to control the speed of the induction motor consists of 4 important stages: Fuzzification, Knowledge Base, Decision-making unit and the Defuzzification. [3]

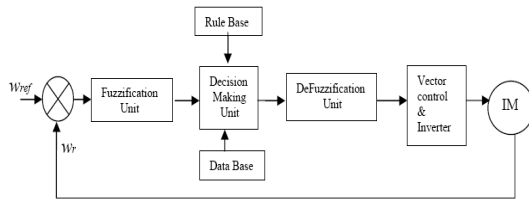

Fig.2 Fuzzy logic controller used for vector control method

The design of fuzzy logic controller start with defining input/output variables of controller. In this case first input variable is speed error  $e(k)$  and second is the change in speed error  $_{e}(k)$ . The output variable of the FLC is the change in the torque.

#### 3.1 Fuzzification:

In this stage the crisp variables  $e(k)$  and  $_{e}(k)$  are converted into fuzzy variables which can be identified by membership function. The fuzzification maps the error and change in error to linguistic labels of fuzzy sets. The proposed controller uses following linguistic labels:

NB (Negative Big), NM (Negative medium), NS (Negative small), NVS (Negative very small), Z (Zero), PVS (Positive Very Small), PM (Positive Medium), PB (Positive Big).

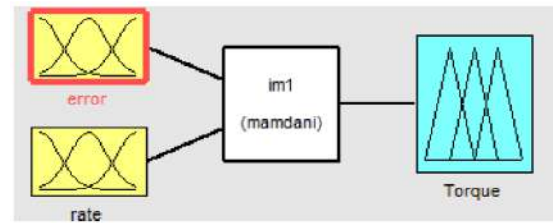

Fig.3 FIS fuzzy editor

### 3.2 Knowledge Base and Decision making Unit:

Knowledge base involves defining the rules represented as IF-THEN rules statements which govern relationship between inputs and output variables in terms of membership functions. In this stage the input variables are processed by inference engine that executes 7x7 rules represented in rule base using fuzzy operator (AND,OR). The mapping of the fuzzy inputs into the required output is derived with the help of a rule base as given in following Table.

Table: 1 Rules of Fuzzy Logic Controller

e \ de	NB	NM	NS	Z	PS	PM	PB
NB	NB	NB	NB	NM	NS	NVS	Z
NM	NB	NB	NM	NS	NVS	Z	PVS
NS	NB	NM	NS	NVS	Z	PVS	PS
Z	NM	NS	NVS	Z	PVS	PS	PM
PS	NS	NVS	Z	PVS	PS	PM	PB
PM	NVS	Z	PVS	PS	PM	PB	PB
PB	Z	PVS	PS	PM	PB	PB	PB

Considering the first rule, it can be interpreted as: IF speed error is NB and rate of change of speed error NB, THEN the output will be NB.

#### 3.3 Defuzzification:

The output of the decision-making unit is given as input to the de-fuzzification unit and the linguistic format of the signal is converted back into the numeric form of data. In this paper, the center of gravity (COA) or centroids method is used to calculate the final fuzzy value  $T(k)$ . This  $e_{de} \text{Torque}$  value is used to calculate  $i_{qs}$ , which in turn used to command the induction motor via 2Φ-3Φ block.

### 4. Neural Network Controller:

The ANN is an Artificial Intelligent technique which is machine like human brain with properties such as learning capability and generalization. It is a system of interconnecting neurons in a network which work together to form the output function. Neuron is a fundamental processing component of a neural network.[5] The performance of ANN relies on member neurons of network collectively. So that it can still perform its overall function even if some of the neurons are not functioning. Thus, they are very robust to error failure. It required a lot of training to understand the model of the plant. To approximate complicated nonlinear functions is the basic property of ANN. [6]

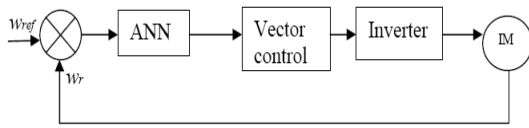

Fig.4 Neural network controller used for vector control

Here, neural network is used to produce torque producing component of current  $i_{qs}$ .

The back propagation training algorithm is used for this network. The following matlab simulation program is developed for this purpose, which train the network using the back propagation training method.[8]

Code:

```
net=newff(minmax(ip11),[2,1],{'tansig','purelin'},'traingd');
net = init(net)
net.trainParam.show =50;
net.trainParam.lr = 0.1;
net.trainParam.epochs =5000;
net.trainParam.goal = 0.001;
[net,tr]=train(net,ip11,op11);
a = sim(net,ip11);
```

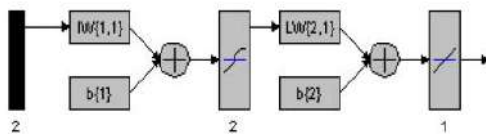

Fig.5 Neural Network Model

### 5. Results and discussion:

Here fuzzy Logic controller and Neural Network controllers are developed. Both of these are constructed into MATLAB/SIMULINK environment. Simulation tests were carried out on the PI controller, FL controller and Neural Network controller. Results are compared.

Figure 6 show the comparison of speed response of PI, FLC and Neural Network controllers at no load. Rise time of fuzzy logic controller is found better compare to conventional PI controller. Rise time of neural network controller is less than that of fuzzy and PI controller. Both fuzzy and neural controller does not find any overshoot. Steady state error is within limit for both fuzzy and neural network controller. Figure 7 (a), Fuzzy logic controller and Neural network controller respectively.

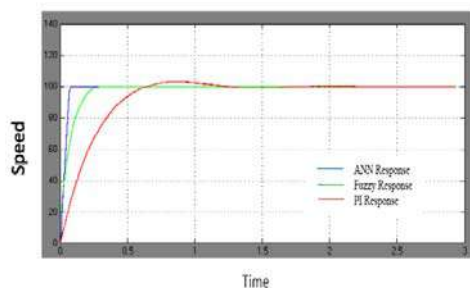
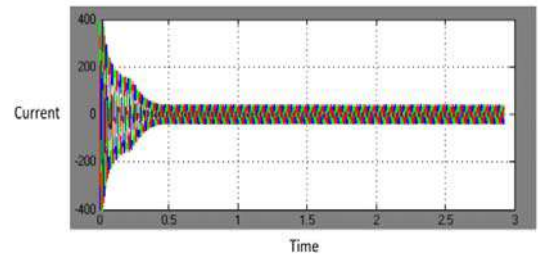
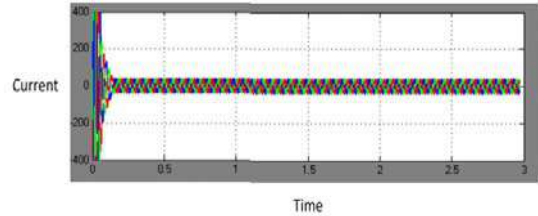

Fig.6 Speed response comparison at no-load



(a) PI



(b) Fuzzy

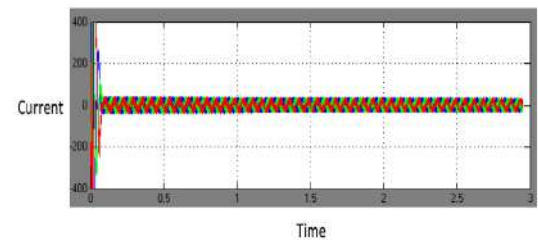

(c) Neural Network

Fig.7 Stator current comparison at no load

### 6. Conclusion:

This paper introduces indirect vector control of induction motor using intelligent techniques. It successfully demonstrates the application of fuzzy logic and neural network for vector controlled induction motor drive. Time response of PI controller is compared with fuzzy logic controller and neural network controller. Performance of Neural Network controller is better in terms of rise time. There is no overshoot in both fuzzy controller and Neural network controller. Also steady state error is acceptable for both the controller. Here the performance and reliability of induction motor is found better.

## 7. References:

- [1]. Bose B.K., "Modern Power Electronics and AC Drives", Prentice Hall
- [2]. Sanjiv Kumar, Bhim singh, J.K.chatterjee, "Fuzzy Logic based speed controller for vector controlled cage induction motor drive "IEEE 1998
- [3]. M. Zerikat, and S. Chekroun, "Design and Implementation of a Hybrid Fuzzy Controller for a High-Performance Induction Motor"
- [4]. Norman Mariun, Samsul Bahari Mohd Noor, Jasronita Jasni, Omar S. Bennanes  
"A Fuzzy logic based controller for vector controlled three-phase Induction motor".IEEE,2004
- [5]. K.M.Hasan, Li Zhang , B.Singh, "Neural Network Control of Induction Motor Drives for Energy Efficiency and High Dynamic Performance"
- [6]. A. K. Sharma, R. A. Gupta, and Laxmi Srivastava," Implementation of neural network in Energy saving of induction motor drives with indirect vector"
- [7]. M. Godoy Simces, Bimal K. Bose, "Neural Network Based Estimation of Feedback Signals for a Vector Controlled Induction Motor Drive"
- [8]. [www.mathwork.com](http://www.mathwork.com)

# Comparative Study of Web Services and Software oriented Architecture for Mobile Augmented Reality System

DR. Bijendra Agrawal<sup>1</sup> , Jatin Shah<sup>2</sup> ,

1.Principal, VKMS College,

2.MCA, Research Scholar,

Vadu

[jatinshah79mca@gmail.com](mailto:jatinshah79mca@gmail.com)

[bijendra\\_agrawal@yahoo.com](mailto:bijendra_agrawal@yahoo.com)

*Abstract:-SOA and Web Services are two buzzwords in the software industry now a days. Most of the people are confused about, What they are?. And they don't know the difference, they take them as synonyms. In this paper, we clearly show the difference between these two.Also the architecture of the Web Services in normal situation and architecture for web services based on SOA in terms of Mobile Augmented Reality System.*

## Introduction :

Einstein made that famous statement many decades ago, and it's still relevant today for building superior software systems. Unfortunately, as anyone who has been in the IT industry for long can point out, far too many software systems have failed Einstein's test. Some are made too simple to carry out the duties they are supposed to perform. Others are made too complex, and the costs of building and maintaining them have rocketed, not to mention the nearly impossible tasks of integrating different systems together. It seems that reaching the right level of simplicity is more like a dream than reality.

## Loose Coupling:

We don't have to look far to find the problems. As we build more and more software systems, we see similar situations and patterns appearing. Naturally, we want to reuse the functionality of existing systems rather than building them from scratch. A real dependency is a state of affairs in which one system depends on the functionality provided by another. If the world only contained real dependencies, Einstein's test would have been satisfied long time ago. The problem is that we also create artificial dependencies along with real dependencies.

If you travel overseas on business, you know that you must bring power adapters along with you or your life will be miserable. The real dependency is that you need power; the artificial dependency is that your plug must fit into the local outlet. Looking at all the varying sizes and shapes of those plugs from different countries, you would notice that some of them are small and compact while many others are big and bulky.

The lesson here is that we cannot remove artificial dependencies, but we can reduce them. If the artificial dependencies among systems have been reduced, ideally, to their minimum, we have achieved loose coupling. In that sense, Einstein was just talking about was loose coupling. We might rework his famous principle thus: "Artificial dependencies should be reduced to the minimum but real dependencies should not be altered."

## SOA Defined and Explained

Now we are able to define a Service Oriented Architecture (SOA). SOA is an architectural style whose goal is to achieve loose coupling among interacting software agents. A service is a unit of work done by a service provider to achieve desired end results for a service consumer. Both provider and consumer are roles played by software agents on behalf of their owners.

This sounds a bit too abstract, but SOA is actually everywhere. Let's look at an example of SOA which is likely to be found in your living room. Take a CD for instance. If you want to play it, you put your CD into a CD player and the player plays it for you. The CD player offers a CD playing service. Which is nice because you can replace one CD player with another. You can play the same CD on a portable player or on your expensive stereo. They both offer the same CD playing service, but the quality of service is different.

The idea of SOA departs significantly from that of object oriented programming, which strongly suggests that you should bind data and its processing together. So, in object oriented programming style, every CD would come with its own player and they are not supposed to be separated. This sounds odd, but it's the way we have built many software systems.

The results of a service are usually the change of state for the consumer but can also be a change of state for the provider or for both. After listening to the music played by your CD player, your mood has changed, say, from "depressed" to "happy". If you want an example that involves the change of states for both, dining out in a restaurant is a good one.

The reason that we want someone else to do the work for us is that they are experts. Consuming a service is usually cheaper and more effective than doing the work ourselves. Most of us are smart enough to realize that we are not smart enough to be expert in everything. The same rule applies to building software systems. We call it "separation of concerns", and it is regarded as a principle of software engineering.

How does SOA achieve loose coupling among interacting software agents? It does so by employing two architectural constraints:

1. A small set of simple and ubiquitous interfaces to all participating software agents. Only generic semantics are encoded at the interfaces. The interfaces should be universally available for all providers and consumers.
2. Descriptive messages constrained by an extensible schema delivered through the interfaces. No, or only minimal, system behavior is prescribed by messages. A schema limits the vocabulary and structure of messages. An extensible schema allows new versions of services to be introduced without breaking existing services.

As illustrated in the power adapter example, interfacing is fundamentally important. If interfaces do not work, systems do not work. Interfacing is also expensive and error-prone for distributed applications. An interface needs to prescribe system behavior, and this is very difficult to implement correctly across different platforms and languages. Remote interfaces are also the slowest part of most distributed applications. Instead of building new interfaces for each application, it makes sense to reuse a few generic ones for all applications.

Since we have only a few generic interfaces available, we must express application-specific semantics in messages. We can send any kind of message over our interfaces, but there are a few rules to follow before we can say that an architecture is service oriented.

First, the messages must be descriptive, rather than instructive, because the service provider is responsible for solving the problem. This is like going to a restaurant: you tell your waiter what you would like to order and your preferences but you don't tell their cook how to cook your dish step by step.

Second, service providers will be unable to understand your request if your messages are not written in a format, structure, and vocabulary that is understood by all parties. Limiting the vocabulary and structure of messages is a necessity for any efficient communication. The more restricted a message is, the easier it is to understand the message, although it comes at the expense of reduced extensibility.

Third, extensibility is vitally important. It is not difficult to understand why. The world is an ever-changing place and so is any environment in which a software system lives. Those changes demand corresponding changes in the software system, service consumers, providers, and the messages they exchange. If messages are not extensible, consumers and providers will be locked into one particular version of a service. Despite the importance of extensibility, it has been traditionally overlooked. At best, it was regarded simply as a good practice rather than something fundamental. Restriction and extensibility are deeply entwined. You need both, and

increasing one comes at the expense of reducing the other. The trick is to have a right balance.

Fourth, an SOA must have a mechanism that enables a consumer to discover a service provider under the context of a service sought by the consumer. The mechanism can be really flexible, and it does not have to be a centralized registry.

## Purpose of the Web Service Architecture

Web services provide a standard means of interoperating between different software applications, running on a variety of platforms and/or frameworks. This document (WSA) is intended to provide a common definition of a Web service, and define its place within a larger Web services framework to guide the community. The WSA provides a conceptual model and a context for understanding Web services and the relationships between the components of this model.

The architecture does not attempt to specify how Web services are implemented, and imposes no restriction on how Web services might be combined. The WSA describes both the minimal characteristics that are common to all Web services, and a number of characteristics that are needed by many, but not all, Web services.

The Web services architecture is an *interoperability* architecture: it identifies those global elements of the global Web services network that are required in order to ensure interoperability between Web services.

## What is a Web service?

A Web service is a software system designed to support interoperable machine-to-machine interaction over a network. It has an interface described in a machine-processable format (specifically WSDL). Other systems interact with the Web service in a manner prescribed by its description using SOAP messages, typically conveyed using HTTP with an XML serialization in conjunction with other Web-related standards.

## Agents and Services

A Web service is an abstract notion that must be implemented by a concrete agent. The agent is the concrete piece of software or hardware that sends and receives messages, while the service is the resource characterized by the abstract set of functionality that is provided. To illustrate this distinction, you might implement a particular Web service using one agent one day (perhaps written in one programming language), and a different agent the next day (perhaps written in a different programming language) with the same functionality. Although the agent may have changed, the Web service remains the same.

## Requesters and Providers

The purpose of a Web service is to provide some functionality on behalf of its owner -- a person or organization, such as a business or an individual. The *provider entity* is the person or organization that provides an appropriate agent to implement a particular service.

A *requester entity* is a person or organization that wishes to make use of a provider entity's Web service. It will use a *requester agent* to exchange messages with the provider entity's *provider agent*.

### Service Description

The mechanics of the message exchange are documented in a Web service description (WSD). The WSD is a machine-processable specification of the Web service's interface, written in WSDL. It defines the message formats, data types, transport protocols, and transport serialization formats that should be used between the requester agent and the provider agent. It also specifies one or more network locations at which a provider agent can be invoked, and may provide some information about the message exchange pattern that is expected. In essence, the service description represents an agreement governing the mechanics of interacting with that service.

### Semantics

The semantics of a Web service is the shared expectation about the behavior of the service, in particular in response to messages that are sent to it. In effect, this is the "contract" between the requester entity and the provider entity regarding the purpose and consequences of the interaction. Although this contract represents the overall agreement between the requester entity and the provider entity on how and why their respective agents will interact, it is not necessarily written or explicitly negotiated. It may be explicit or implicit, oral or written, machine processable or human oriented, and it may be a legal agreement or an informal (non-legal) agreement. While the service description represents a contract governing the mechanics of interacting with a particular service, the semantics represents a contract governing the meaning and purpose of that interaction. The dividing line between these two is not necessarily rigid. As more semantically rich languages are used to describe the mechanics of the interaction, more of the essential information may migrate from the informal semantics to the service description. As this migration occurs, more of the work required to achieve successful interaction can be automated.

There are many ways that a requester entity might engage and use a Web service. In general, the following broad steps are required, (1) the requester and provider entities become known to each other (or at least one becomes know to the other); (2) the requester and provider entities somehow agree on the service description and semantics that will govern the interaction between the requester and provider agents; (3) the service description and semantics are realized by the requester and provider agents; and (4) the requester and provider agents exchange messages, thus performing some task on behalf of the requester and provider entities. (I.e., the exchange of messages with the provider agent represents the concrete manifestation of interacting with the provider entity's Web service.) Some of these steps may be automated, others may be performed manually.

### The Architectural Models

This architecture has four models, illustrated in. Each model in is labeled with what may be viewed as the key concept of that model.

The four models are:

1) The Message Oriented Model focuses on messages, message structure, message transport and so on — without particular reference as to the reasons for the messages, nor to their significance.

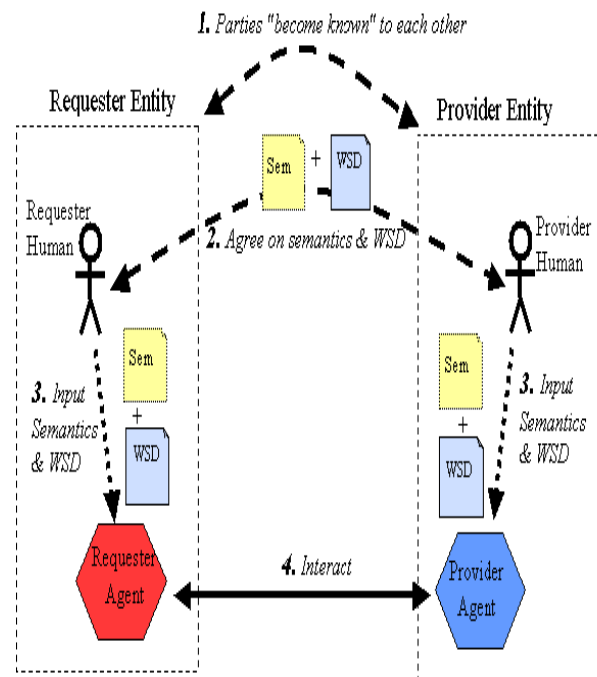
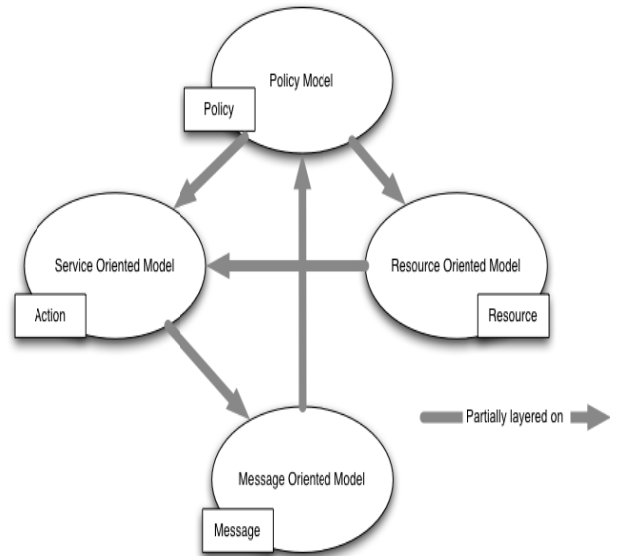

The essence of the message model revolves around a few key concepts illustrated above: the agent that sends and receives messages, the structure of the message in terms of message headers and bodies and the mechanisms used to deliver messages. Of course, there are additional details to consider:



the role of policies and how they govern the message level model. The abridged diagram shows the key concepts; the detailed diagram expands on this to include many more concepts and relationships.

2) The Service Oriented Model focuses on aspects of service, action and so on. While clearly, in any distributed system, services cannot be adequately realized without some means of messaging, the converse is not the case: messages do not need to relate to services.

The Service Oriented Model is the most complex of all the models in the architecture. However, it too revolves around a few key ideas. A service is realized by an agent and used by another agent. Services are mediated by means of the messages exchanged between requester agents and provider agents.

A very important aspect of services is their relationship to the real world: services are mostly deployed to offer functionality in the real world. We model this by elaborating on the concept of a service's owner — which, whether it is a person or an organization, has a real world responsibility for the service.

Finally, the Service Oriented Model makes use of meta-data, which, as described in **Service Oriented Architecture**, is a key property of Service Oriented Architectures. This meta-data is used to document many aspects of services: from the details of the interface and transport binding to the semantics of the service and what policy restrictions there may be on the service. Providing rich descriptions is key to successful deployment and use of services across the Internet.

3) The Resource Oriented Model focuses on resources that exist and have owners.

The resource model is adopted from the Web Architecture concept of resource. We expand on this to incorporate the relationships between resources and owners.

4) The Policy Model focuses on constraints on the behavior of agents and services. We generalize this to resources since policies can apply equally to documents (such as descriptions of services) as well as active computational resources.

Policies are about resources. They are applied to agents that may attempt to access those resources, and are put in place, or established, by people who have responsibility for the resource.

Policies may be enacted to represent security concerns, quality of service concerns, management concerns and application concerns.

### **Conclusion:**

The web services approach is based on a maturing set of standards that are widely accepted and used. This widespread acceptance makes it possible for clients and services to communicate and understand each other across a wide variety of platforms and across language boundaries. Design architecture for mobile augmented Reality System SOA based Web Services played vital role due to the limitation of mobile device.

### **References:**

<http://www.w3.org/TR/2004/NOTE-ws-arch-20040211/>

<http://www.w3.org/TR/ws-arch/>

<http://www.w3.org/TR/2003/WD-ws-arch-20030808/>

[www.service-architecture.com](http://www.service-architecture.com)

<http://www.w3c.org/2002/ws/arch>

Web Services and Service-Oriented Architectures: The Savvy Manager's Guide  
by Douglas K. Barry

# QUEST (Quick Unbiased Efficient Statistical Tree): An efficient algorithm of Classification Tree in Data Mining

<sup>1</sup>Mr. U. N. Parmar, <sup>2</sup>Mr. A. K. Ranpura, <sup>3</sup>Mr. V. K. Jadeja, <sup>4</sup>Mr. R. P. Joshi  
<sup>1,3,4</sup>Lecturer, Dept of IT, CCET, Wadhwan, Gujarat., <sup>2</sup>Lecturer, MCA Dept, CCET, Wadhwan, Gujarat.  
ureshparmar13@yahoo.co.in, [ranpura.avalik.2007@gmail.com](mailto:ranpura.avalik.2007@gmail.com), [vkjadeja\\_itworld@yahoo.co.in](mailto:vkjadeja_itworld@yahoo.co.in), [rah1985@gmail.com](mailto:rah1985@gmail.com)

**Abstract:-** Classification trees based on exhaustive search algorithms tend to be biased towards selecting variables that afford more splits. As a result, such trees should be interpreted with caution. In this paper QUEST (QUICK UNBIASED EFFICIENT STATISTICAL TREE) algorithm is proposed which has negligible bias. Its split selection strategy yields binary splits and the final tree can be selected by a direct stopping rule or by pruning. Real and simulated data are used to compare QUEST with the exhaustive search approach. QUEST is shown to be substantially faster as QUEST generates random no. of trees like forests and the size and classification accuracy of its trees are typically comparable to those of exhaustive search. QUEST classifies the data from dataset file like ARFF. QUEST works with categorical as well as continuous attributes. QUEST gives the better result compare to other existing classifiers such as SimpleCart, ID3, J48 etc. QUEST gives the statistical binary decision tree. It is the tree structured classification algorithm which gives the efficient tree. QUEST also does pruning and deals with missing values using cross validation. QUEST uses the univariate splits to split the node instead of surrogate splits. This thesis gives detailed description about the QUEST algorithm.

## 1. INTRODUCTION

In Data Mining, many Decision Tree classification methods are available. But each method has some drawback. The basic decision tree method ID3, which can easily generate the tree but neither prune the tree nor deals with missing values. Same way CHAID generates non binary decision tree but takes time to generate the tree. First the basic decision tree algorithm ID3 has been found. But it was having many disadvantages. So many new decision tree algorithms were enhanced from basic and some problems can be solved by new algorithms. But day by day data becomes larger. So there is a need to classify the data from large dataset quickly with good accuracy. QUEST which stands for QUICK UNBIASED EFFICIENT STATISTICAL TREE can classify data more quickly and with low cost because QUEST has negligible bias. So by using QUEST algorithm the problem of classifying data quickly from large dataset can be easily solved. QUEST generates a binary decision tree; therefore it is easy to classify the data using QUEST [3] [5].

QUEST uses statistical imputation instead of surrogate splits as in CART. For both ordered variable and categorical variable, different split point selection method is used. [3]. QUEST also deals with missing values. QUEST is based on statistics; therefore it uses imputation for missing values. are two methods- Hot Deck imputation and Regression imputation. Hot-deck imputation fills in missing values on incomplete records using values from similar, but complete records of the same dataset. Regression computation is commonly used when auxiliary data are available. [8][7]

The QUEST algorithm can be used in applications such as Medical Research, Chemical Laboratory, Food Chemistry, Weather Forecasting, Neural Network etc.

## 2. CONCEPT OF CLASSIFICATION

Classification is a data mining (machine learning) technique used to predict group membership for data instances. Classification and prediction are two form of data analysis that can be used to extract models describing important data classes or to predict future data trends for which the classifiers are used [9].

### 2.1 Classification Methods

#### 2.1.1 Decision Tree

A decision tree is a flow chart like tree structure in which each branch (nonleaf) node represents a choice between a number of alternatives, and each leaf (terminal) node represents a classification or decision. A decision tree can be used to classify an example by starting at the root of the tree and moving through it until a leaf node, which provides the classification of the instance.

Decision Trees are so popular just because, its construction does not require any domain knowledge or parameter setting, and is appropriate for exploratory knowledge discovery. Decision trees can handle high dimensional data. Their representation of acquired knowledge in tree form is intuitive easy to assimilate. The learning and classification steps of decision tree induction is simple and fast. In general Decision Tree classifiers have good accuracy.

In advantages of Decision Trees it can handle both nominal and numeric input attributes, can handle datasets that may have errors, handle datasets having missing values, it may reduce cost even if the cost of classification is high and no need of domain knowledge.

In disadvantages of Decision tree that most of its algorithms have discrete values as target values, reduce performance in complex interactive attributes, sometimes provide over-sensitivity to the training set, and sometimes deteriorate when handling too much missing values.

### 2.1.2 Binary Decision Tree

Binary Decision Trees (BDTs) are essentially computer science binary tree structures, enabling a conclusion state to be reached from a root node (which you could think of as a question or decision choice) via a set of binary (yes/no) decision states. In more down-to-earth terms, it is a technique to allow a conclusion to be made based on a specified problem definition. Decision trees are a popular technique in classification systems as well as in computer game AI and there are a whole host of related algorithms of interest, e.g. ID3. A BDT comprises of a set of body nodes which are attached to a root node and which terminate at n leaf nodes. The root and each body node must have connections to two other nodes; otherwise they are classed as terminating nodes where a decision outcome state has been reached. The uniform design of the tree based on two nodes leads to it being called a binary decision tree.

The leaf nodes in a BDT represent a set of terminating "answers" or decision outcome states as I have called them, the root and body nodes representing the "questions". The BDT arrives at a decision state by gaining answers to the body (yes/no) nodes. The nature of the response to a particular question dictates which node should be followed to the next question (or answer if a leaf node is arrived at). In the case of a binary decision tree the responses can only be "yes" or "no", each corresponding to one of the two available branches at each body node.

### 2.1.3 Various Advanced Decision Trees

**1. ID3:** The ID3 algorithm is considered to be very simple decision tree algorithm. Using information gain as splitting criteria, ID3 ceases to grow when all instances belong to a single value of a target feature or when best information gain is not greater than zero. ID3 does not apply any pruning process nor handles missing values.

**2. C4.5:** It is an evolution of ID3 which uses gain ratio as splitting criteria. The splitting ceases when number of instances to be split is below a certain threshold. Error based pruning is performed after the growing phase. C4.5 can handle numeric attributes. It can also induce from the training set that incorporates missing values by using corrected gain ratio criteria.

**3. CART:** CART stands for Classification and Regression tree. CART partitions the data into two subsets so that the records

within each subset are more homogeneous than in the previous subset. It is a recursive process—each of those two subsets is then split again, and the process repeats until the homogeneity criterion is reached or until some other stopping criterion is satisfied. It also enables users to provide prior probability distribution.

**4. CHAID:** A CHAID stands for Chi Squared automatic interaction detection was originally designed to handle nominal attributes only. CHAID evaluates all of the values of a potential predictor field. It merges values that are judged to be statistically homogeneous (similar) with respect to the target variable and maintains all other values that are heterogeneous (dissimilar). CHAID "build" non-binary trees based on a relatively simple algorithm that is particularly well suited for the analysis of larger datasets.

**5. QUEST:** It is a relatively new binary tree-growing algorithm (Loh and Shih, 1997). It deals with split field selection and split-point selection separately. The univariate split in QUEST performs approximately unbiased field selection. That is, if all predictor fields are equally informative with respect to the target field, QUEST selects any of the predictor fields with equal probability. QUEST affords many of the advantages of CART, but, like CART, your trees can become unwieldy. You can apply automatic cost-complexity pruning to a QUEST tree to cut down its size. QUEST uses surrogate splitting to handle missing values.

## 3.COMMON CRITERIAS OF ANY TREE BASED CLASSIFICATION METHOD.

**Merging** – relative to the target variable, non-significant predictor categories are grouped with the significant categories.

**Splitting** – selecting the split point. Variable to split population is chosen by comparison to all others.

**Stopping** – rules which determine how far to extend the splitting of nodes.

**Pruning** – branches that add little to the predictive value of the tree are removed.

## 4. QUEST ALGORITHM

**Algorithm:** Generate a binary decision tree using QUEST Algorithm

**Input:**

- Dataset D, which is a set of training tuples and their associated class labels
- Attribute\_list, which is the set of candidate attributes
- Attribute\_selection Method, a procedure used to split the node and partition the data into individual classes.

**Output:** A Statistical Binary Decision Tree

**Method:**

1. Create the Root node R
2. If tuples in D are all of the same class c, then return R as a leaf node labeled with the class C
3. If attribute\_list is empty then return R as a leaf node labeled with the majority class in D
4. Else Association between each input attribute and target attribute is computed using ANOVA-F test if attribute is ordinal or Chi-square test if attribute is categorical
5. If attribute is multi nominal then clustering is used to create two super classes. The attribute that obtains the highest association with the target attribute is selected for splitting.
6. Apply the stopping criteria
7. Prune the tree using Pre-pruning or Post-pruning.
8. Apply ten fold cross validation to deal with Missing values
9. Output the binary decision tree

**Fig 1. The QUEST Algorithm**

QUEST (Quick, Unbiased, Efficient, Statistical Tree) is a binary-split decision tree algorithm for classification and data mining technique. The objective of QUEST is similar to that of the CART (classification and Regression) algorithm but the major differences are:

- QUEST uses an unbiased variable selection technique by default
- QUEST uses imputation instead of surrogate splits to deal with missing values.
- QUEST can easily handle categorical predictor variables with many categories

A *variable selection scheme* is proposed for constructing multivariate classification trees. It utilizes conditional independence test derived from hierarchical log linear model for three-way contingency table to control selection bias. Furthermore, it is compared with some existing selection methods in terms of selection power. Simulation results show that our method is unbiased and has better selection power.

QUEST is shown to be substantially faster and the size and classification accuracy of its trees are QUEST that

- 1) has negligible variable selection bias
- 2) Retains the computational simplicity of FACT technique
- 3) Includes pruning as an option
- 4) Yields binary splits

QUEST method is demonstrated to be much better than exhaustive search in terms of variable selection bias and computational cost.

QUEST is a tree-structured classification algorithm that yields a binary decision tree like CART. The reason for yielding a binary tree is that a binary tree may allows techniques such as *pruning, direct stopping rules and surrogate splits* to be used. Unlike CHAID and CART, which handle variable selection and split point selection simultaneously during the tree growing

process. QUEST was demonstrated to be much better than exhaustive search methods in terms of variable selection bias and computational cost. In terms of classification accuracy, variability of split points and tree size, however, there is still no clear winner when univariate splits are used.

For each split, the association between each input attribute and the target attribute is computed using the ANOVA-F test or Leven's test(for ordinal and continuous attribute) or Pearson's Chi-Square (for nominal attribute). An ANOVA F-statistics is computed for each attribute. If the largest F-statistics exceeds a predefined threshold value, the attribute with the largest F-value is selected to split the node. Otherwise, leven's test for unequal variance is computed for every attribute. If the largest levene is greater than a predefined threshold value, the attribute with the largest levene value is used to split the node..

If the target attribute is multinomial, two means clustering is used to create two super-classes. The attribute that obtains the highest association with the target attribute is selected for splitting.

**4.1 Advantages of QUEST Algorithm compared to other Decision Tree Algorithms**

- Variable selection Bias
- Computational Accuracy/Computational cost
- Variability of split points & Tree size
- QUEST is shown to be substantially faster and the size and classification accuracy of its trees are comparable to these of exhaustive search.

**4.2 Components of QUEST analysis**

Basic components in a QUEST analysis are as follows:

- *One or more predictor variable:* Predictor variables can be continuous, ordinal or nominal variables.
- *One target variable:* The target variable must be nominal.
- *Settings for various QUEST parameters:* The settings include alpha level for variable selection, priors for the categorical target variable, profit values and misclassification costs, and the variable used as the frequency weight variable.

**4.3 Comments on QUEST analysis**

- With categorical dependent variables only.
- If it is important to have an unbiased tree.
- If you have a large or complex data set and need an efficient algorithm for estimating the tree.
- Or CART, if you want to restrict your tree to binary splits.
- If the classification model produced by QUEST is measurably better than that produced by the other methods.
- CART to handle missing values by surrogate splits.
- Case weight is ignored in the QUEST option.

Like CHAID, the cost matrix is not directly involved in the

QUEST tree growing process.

However, for a symmetric cost matrix, cost information can be incorporated into the model by adjusting the priors based on the cost matrix.

#### 4.4 Stopping Rules

Each of the methods recursively splits nodes until one of the stopping rules is triggered.

The following conditions will cause the algorithm to terminate:

- The maximum tree depth has been reached.
- No more splits can be made, because all terminal nodes meet one or more of the following conditions:
- There is no significant predictor variable left to split the node.
- The number of cases in the terminal node is less than the minimum number of cases for parent nodes.

#### 4.5 Dealing with missing values

QUEST uses *statistical imputation* instead of surrogate splits while handling missing values.

Surrogate splitters are used to classify rows that have missing values in the primary splitter. When a row is encountered that has a missing value on the primary splitter.

#### Data Imputation for Missing Values

Two of the most commonly used techniques by QUEST for data imputation are *hot-deck imputation* and *regression imputation*.

**Hot-deck imputation** fills in missing values on incomplete records using values from similar, but complete records of the same dataset.

**Regression imputation** is commonly used to compensate for item non response when auxiliary data are available. It is common practice to compute survey estimators by treating imputed values as observed data and using the standard unbiased (or nearly unbiased) estimation formulas designed for the case of no non response.

### 5. EXPERIMENTS AND RESULT

To evaluate the performance of the QUEST we are using some of the well known UCI (University of California Irvine) datasets [10]. The performance of the classification-based method is affected by several factors such as the number of records, the number of attributes, the number of records on which model is built, amount of missing values etc.

Table1 describes the three different UCI datasets with number of instances that we have used for performance study.

Dataset	No of Instances
Soybean	5000
Mushroom	9000
Waveform	10000

**Table 1. Summary of datasets**

The QUEST algorithm's performance is tested & compared with other existing algorithms such as J48, DecisionStump,

SimpleCart. Compared to other algorithms, QUEST is giving better accuracy. The comparison using Soybean dataset is given in table 2 and relevant graph is given in fig 2.

Classifier	Accuracy(Soybean)
QUEST	93.41
J 48	91.50
Decision Stump	28
Simple Cart	91.21

**Table 2. Classifier vs Accuracy**

We have also done comparison with Mushroom and Waveform datasets with different number of instances. We found that most of the cases QUEST giving better result.

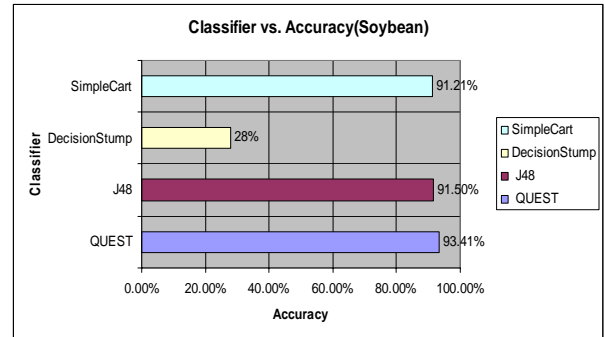

**Figure 2. Comparison of different classifiers' accuracy on Soybean dataset using WEKA tool. (Accuracy shows in percentage). The x-cordinates shows the accuracy, y-cordinates shows classifiers.**

### 6. CONCLUSION

This paper comprehensively shows how the QUEST algorithm being run and also done the comparison of QUEST with other classifiers with large datasets. So we can conclude that with negligible bias, binary split strategy and stopping rules, QUEST generating attractive results as compare with other classifier trees.

## 7. REFERENCE

- [1] Narsimha Raju Alluri : “Evaluation of Data Mining Methods to support Data Warehouse Administration”, University of Applied Sciences, Furtwangen-Germany, 2005.
- [2] Wei Peng, Juhua Chen and Haiping Zhou: “An Implementation of ID3 Algorithm”, University of New South Wales, Sydney-Australia, 1997
- [3] Wei-Yin Loh and Yu-Shan Shih: “Split selection Methods for Classification Trees”, University of Wisconsin-Madison, 1997.
- [4] Mike Cameron-Jones and Andrew Charman-Williams: “Stacking for Misclassification Cost Performance”, University of Tasmania, Australia, 1999.
- [5] Loh and Shih: “Comparison of Old and New Classification Algorithms”, Machine learning 2000.
- [6] Yu Shan Shih: “QUEST User Manual”, National Chung Cheng University, Taiwan, 2004.
- [7] Hendrik Blockeel & Jan Struyf: “Efficient algorithms for Cross Validation”, Katholieke University, Belgium, 2002.
- [8] Paul E. Utgoff, Neil C. Berkman, “Decision Tree Induction Based on Efficient Tree Restructuring” Clouse Department of Computer Science, North Carolina A&T State University, Greensboro, NC 27411.
- [9] U N Parmar, A K Ranpura, S J Agravat, “Multiple Classifier System using bagging method”, vol 4, issue 1, IJTES international journal, Sangli, Jan 2010.
- [10] Machine learning UCI dataset repository  
<http://www.ics.uci.edu/mllearn/MLRepository.html>

# Performance Analysis of Gun-shot Direction Detection System for ak47 gun shot

<sup>1</sup>Anju M. Vasdewani <sup>2</sup>Dr. G.R.kulkarni <sup>3</sup>R.S.Gajre

<sup>1</sup> Student, M.E. (E.C.), C.U.Shah College of Engineering & Technology, Wadhwan City

<sup>2</sup>Principial, C.U.Shah College of Engineering & Technology, Wadhwan City

<sup>3</sup>Asst.Prof of Electronics & Communication Department

[amvasdewani@aits.edu.in](mailto:amvasdewani@aits.edu.in) [grkulkarni29264@rediffmail.com](mailto:grkulkarni29264@rediffmail.com) [rakeshgajre@gmail.com](mailto:rakeshgajre@gmail.com)

**ABSTRACT:-THIS SYSTEM CAN DETECT THE SOURCE OF GUN FIRE. THE WORKING PRINCIPLE OF THE SYSTEM IS THAT SOUND WAVES TRAVEL AT FINITE SPEED AND A SINGLE SOUND PICKED UP BY MULTIPLE MICROPHONES SPATIALLY DEPLOYED, WOULD BE OFFSET IN TIME. IN SIMPLE PARLANCE, THE MICROPHONE WHICH IS NEAREST TO THE SOUND SOURCE WILL PICK UP THE SOUND FIRST AND THAT WHICH IS FARTHEST WILL BE THE LAST TO HEAR IT. TO MAKE THE USE OF THIS PRINCIPLE IN A PRACTICABLE GADGET, NUMEROUS MICROPHONES ARE PLACED IN SPECIFIC MANNER IN TWO PLANES AND THE OUTPUT OF EACH MICROPHONE IS CONNECTED TO A PROCESSING CIRCUIT. THE PROCESSING CIRCUIT HAS TO ACCOMPLISH SOME VERY IMPORTANT TASKS. THE FIRST WOULD BE TO AUTHENTICATE THE SOUND AS A AK47 GUN SHOT AND TO STOP THE SYSTEM FROM GENERATING FALSE ALARMS WHEN IT PICKS UP A FIRE CRACKER OR A TIRE BURST. TO DO THIS SOUND COMPARISON ALGORITHM IS BEING IMPLEMENTED USING MATLAB. ONCE THIS IS DONE THE REST OF THE PROCEDURE IS VERY STRAIGHT FORWARD. THE DELAY BETWEEN TWO MICROPHONES IN HORIZONTAL PLANE WILL DETERMINE THE DIRECTION OF GUN FIRE.THE INSTRUMENT CAN BE A GREAT HELP TO THE MILITARY AND OTHER SECURITY FORCES ON PATROL. SUCH AN INSTRUMENT WOULD BE A BOON TO SECURITY FORCES IN SURVIVING GUERILLA ATTACKS IN MILITANCY INFLECTED AREAS SUCH AS THE KASHMIR VALLEY AND THE EASTERN STATES. THE DISPLAY OF THE SYSTEM CAN BE CONSTRUCTED IN ANY WAY AS THE USER WOULD LIKE IT FOR INSTANCE IF THE MILITARY IS ABOUT TO USE IT, A PREFERABLE DISPLAY WOULD BE A CLOCK LIKE DIAL WITH LEDs MOUNTED AT DIFFERENT 'O CLOCKS' WITH WHICH THEY ARE VERY FAMILIAR ALONG WITH SOME AUDIO WARNING. IN SUCH A SYSTEM IF THE SYSTEM DETECTS THAT A SHOT HAS BEEN FIRED FROM THE FRONT THE 12 O CLOCK LED WILL LIGHT UP. THIS SYSTEM CAN ALSO BE MOUNTED ON PATROLLING VEHICLES.**

## Field of the Invention

The present invention generally relates to gunshot detection. More particularly, the present invention is directed to using multiple installations of sound detection, recording devices for detecting firing of a gun or an explosion, identifying of a location of such firing or explosion, and of a possible suspect of such firing or explosion.

It would therefore be desirable to provide a system to detect a gunshot, determine the direction from which it was fired, and initiate recording of the area of the event immediately upon the event occurring.

Here the task is divided into three different parts

- 1) Comparing input signal(gun shot or other sound) with stored ak47 gun shot, which decides whether direction is to be detected or not
- 2) Using parallel port of computer for indication if input signal is gun shot. Direction detection hardware is going to

display direction only when input signal is gunshot and output of parallel port is 1.

3) Hardware of direction detection consists of 8 microphones, supported by 8 preamplifiers and monostable multivibrators. Output of all 8 multivibrator is provided to port of microcontroller, and based on which input comes first direction is detected.

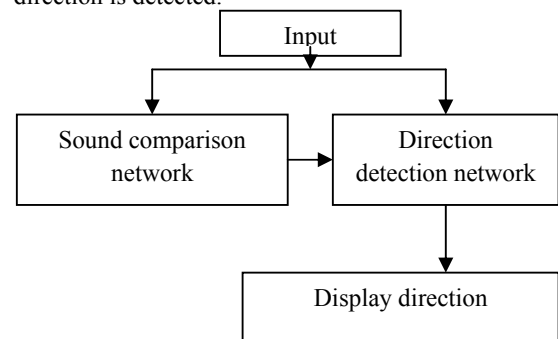

Figure 1: Layout of system

Figure 1 shows flow layout of system in which the whole task is divided into 2 portions. Signal comparison and direction detection. As shown in figure signal comparison loop and direction detection loop are working in parallel. When any input signal (acoustic in nature) comes, microphone that is connected to signal comparison loop picks up a sound and is given as an input to matlab for comparison purpose to decide whether input is ak47 or not. At a same time microphones connected to direction detection system would pick up sound and will determine direction as per input from which microphone is coming first. Result of direction is stored in one of the working register of direction detection circuit.

Direction detection circuit will not display the output till it will get input from signal comparison network. If input signal is ak47 then output of one parallel port line is given to direction detection circuit to inform that input was ak47. Then direction will be displayed.

## Comparison of input signal

First task is to compare input signal with pre stored gun shot signal continuously. Using wavread command, matrix of stored signal is generated and using wavrecord command matrix of input signal is generated. Then using algorithm for comparison between two sounds their similarity is checked.

Comparison between two signals(audio signals) can be done using cross correlation which is the basic method of comparing frequency components of two signals. Figure 2 shows original ak47 signal and figure 3 shows recorded signal.

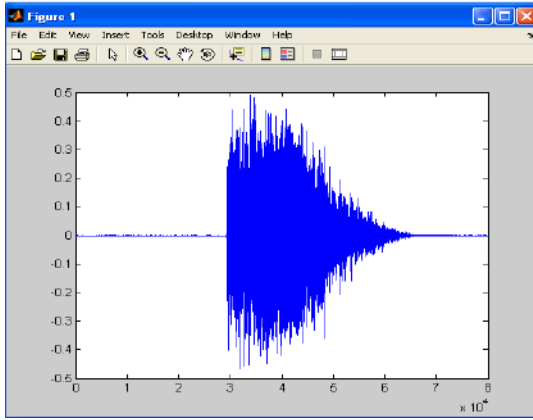

Figure 2: Original ak47 signal

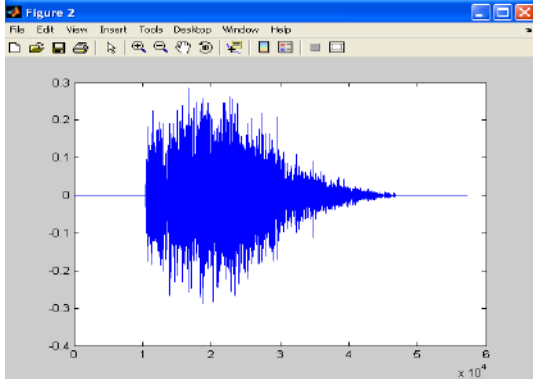

Figure 3: Recorded ak47 signal

As shown in above case as microphone was very near to source of gunshot there is 82.252% of cross correlation between input and stored sound.

Similarly table 1 shows cross correlation factor of original ak47 sounds with other signals. Here based on user's accuracy requirement system parameter for accuracy can be modified. It can be easily achieved that if cross correlation factor is greater than some threshold level then output of parallel port will be high other wise it will be low.

Another requirement of real time system is time required for processing should be as small as possible other wise if processing time is more then, required task of pointing suspected region ( if this system is used for security) can not be achieved. Processing time can only be reduced by doing some signal processing on input signal. For example if input signal is below some threshold and that can be defined by range of device. So that if input is less than some threshold, direction will not be displayed.

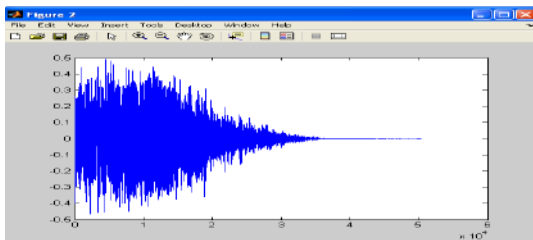

Figure 4: Truncated part of original ak47

Suppose ak47 is of 2 second signal, then recording cannot be done for exactly 2 second but more than 2 seconds. Solution to above problem can be achieved by truncating the portion which is below some threshold level so comparison time required will be less. Here figure 2 shows original ak47 and figure 3 shows recorded ak47. Direction comparison between them requires atleast 6 minutes to check whether recorded signal is ak47 or not, whereas comparison between their truncated part as shown in figure 4 and figure 5 respectively requires only 1 minute and 18 seconds for comparison purpose.

Other sound	Crosscorrelation(%)
Ak47	100
Ak47b	82.252
Ak47l	44.917
Explo	3.7
Explob	3.8
Gs	6.09
Gsb	6.149
Spoken word	6.88

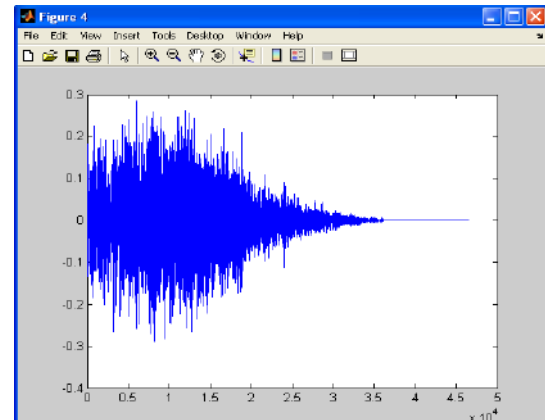

Figure 5: Truncated part of recorded ak47

## SYSTEM FOR DIRECTION DETECTION

### Introduction

Presently I have devised a system that senses direction with the help of only two microphones. Later I intend to construct a system that uses eight microphones to sense the direction of the sound source from all the four directions. The block diagram of the system is as shown in Figure 6. The sound is picked up simultaneously by the two condenser microphones for direction detection and one dedicated microphone having good frequency response is used as an input transducer for recording purpose and comparison purpose for computer. The outputs of these microphones are quite low and thus are amplified by their corresponding identical pre amplifiers. These amplified signals are used to trigger two different monostables. Both these monostables have identical time periods. The outputs of these monostables are used to provide interrupt to the microcontroller. The output of the system is a clock dial type led display which is driven by the controller port which has been configured as the output port by the software.

Table 1: Cross correlation factor of ak47 with other sounds



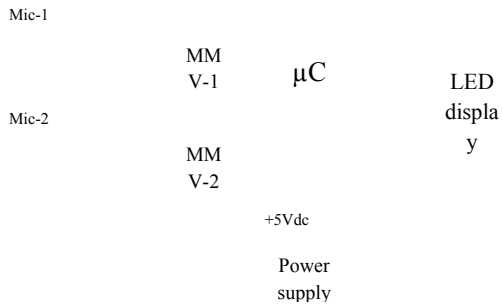

Figure 6: Block diagram of direction detection system using 2 microphones

Presently my system is working for two directions only i.e. north and south or it can be said that its resolution is 180 degree. Figure 7 shows flow chart of direction detection system.

As shown in figure 6 direction detection system is after initialization waiting for input. If there is any acoustic signal present then depending on place of gun fire (i.e. source of sound wave), LED will glow up for some time delay set using software. There are 2 basic problems if above system is used. They are as (1) If there are simultaneous gun shot from different direction then this system will not be able to distinguish whether source of gun fire is from which particular direction. (2) If gun fire is from center (i.e. all microphones receive signal of gun shot simultaneously) then based on which hardware having less propagation delay will generate output first, which gives wrong indication. (as here hardware for all sensors i.e. preamplifier, monostable multivibrator are constructed using same component value but practically due to tolerance they will not be same).

Figure 7: Flowchart of microcontroller based system for direction detection using 2 microphones

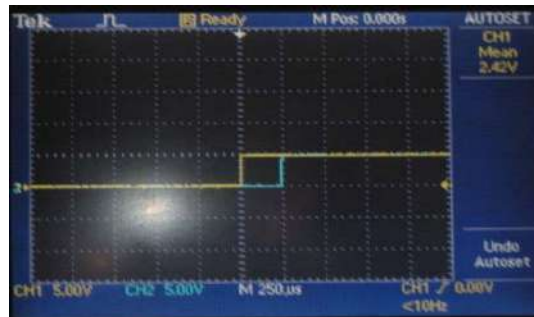
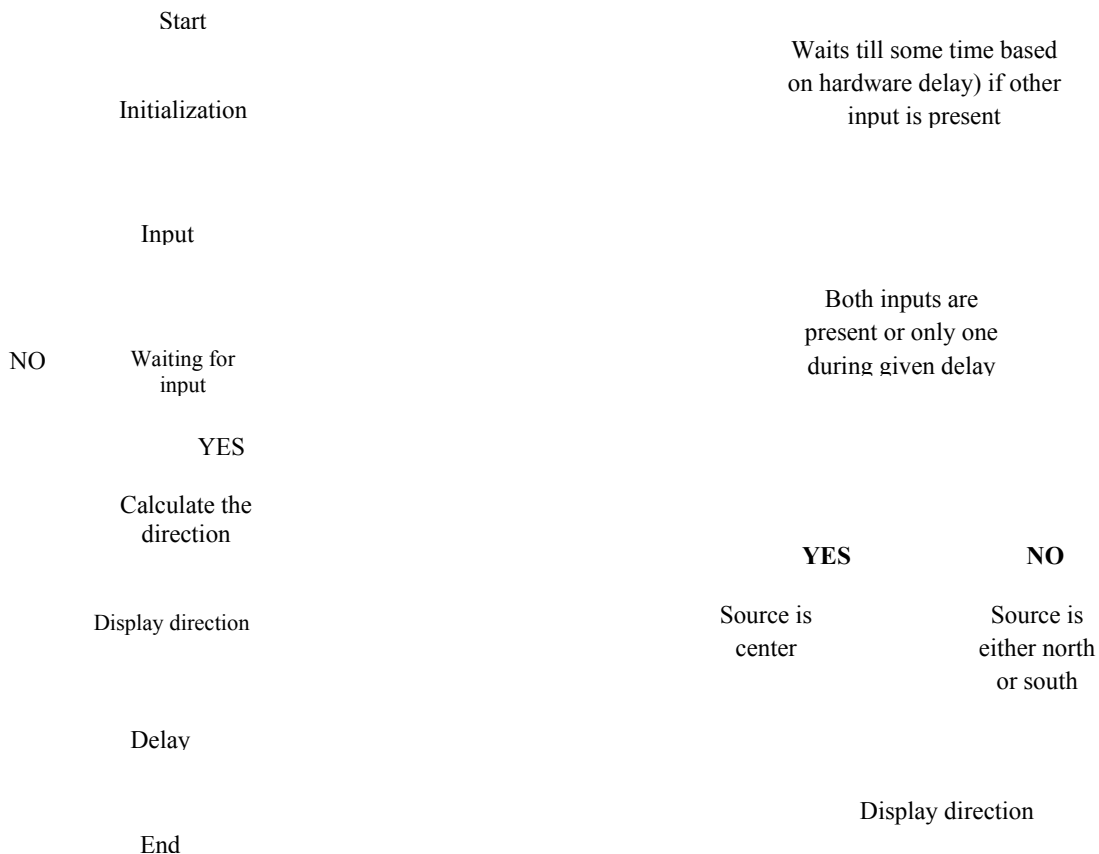

Figure 8: Propagation delay between of two similar hardware



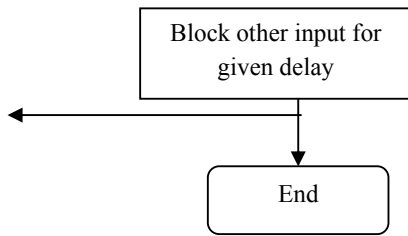

Figure 9: Flowchart of modified system

For solution of 1<sup>st</sup> problem one assumption is made i.e. for given delay only one gun shot can be detected.

If there are simultaneous gun fires then system will not be able to detect every gun shot but is limited to only some which depends what is the delay between gun shots. It is achieved by blocking the input for some time delay.

Solution to 2<sup>nd</sup> problem is made by finding propagation delay of two hardware; one which is faster compared to other is delayed using software technique. i.e. if input to both microphones comes during some prescribed time delay, then source is center other wise it is from any particular direction. Figure 8 shows time delay in two similar hardware measured using DSO.

Solution to above two problems is shown in figure 9 which shows flow chart for two microphone direction detection system. As stated above here another input is blocked after occurrence of one input for some time duration and to get correct center reading additional delay is added using software techniques.

## CONCLUSION

In this dissertation, I have proposed the basic issues in designing gun shot direction detection which is used for military and homeland security. The design has to very sensitive to decide whether gun shot detection was for ak47 so

that false direction detection can be prevented. Also while designing hardware for direction detection one has to think for critical timings of this system, as microcontroller (or any other processor) is responding in microseconds, so delay produced by each hardware should be equal, which challenges the component accuracy. Any change in time delay needs to corrected either in hardware or using software loop.

## REFERENCES

- 1 Muhammad Ali Mazidi, Janice Gillispie Mazidi, Rolin D. Mckinlay, "The 8051 Microcontroller and Embedded", Second Edition, Pearson Prentice Hall, 2006
- 2 Kenneth J. Ayala, "The 8051 Microcontroller Architecture, Programming & Applications", Second Edition, Penram International Publishing (India)
- 3 Lapin, Brett D., Besser, Nicholas D, "Gun shot digital imaging system", United states patent 6965541, 2005
- 4 [www.shotspotter.com](http://www.shotspotter.com)

# MODIFIED BAGGING METHOD: A NOVEL APPROACH OF MULTIPLE CLASSIFICATION IN DATA MINING

Mr. Uresh N Parmar<sup>1</sup> , Mr. Krunal G Patel<sup>2</sup>, Ms. Meenakshi<sup>3</sup>

<sup>1,2</sup>.Department of Information Technology,  
C.C.E.T, Wadhwan, Gujarat, India

<sup>3</sup>.Department of Information Technology  
K.I.T.R.C., Kalol, Gujarat, India

[meenakshi.saroha@gmail.com](mailto:meenakshi.saroha@gmail.com), [ureshparmar13@yahoo.co.in](mailto:ureshparmar13@yahoo.co.in)

**Abstract:**-Classification is the process of deriving unknown values of certain attributes of interest based on the values of the other attributes. Multiple classifier system (MCS) has shown to be an effective technique for classification. MCS construct a set of classifiers and then classify new data sets by taking votes of their prediction. Bagging is basically a multiple classifier ensemble based system improving the accuracy of the single base classifier learned on entire data, by using combination of models. In basic bagging approach, different bags (models) are created by sampling (with replacement) of the original training data set. Each bagged train set is independently used to generate a classifier, and classifier predictions are combined using as a simple majority voting system. However there is no guarantee that bagging will improve the performance of the base classifier every time, in some situations it fails to do so. Also bagging may work deterioratically in large dataset as well.

The main objective of the paper is to overcome the above defined problem, by using the same bootstrapping and aggregating method. Bagged predictors are constructed discarding the bootstrap samples which generate the accuracy which is less than the base classifier accuracy considering the involvement of the base classifier at the time combining all the models. The approach would be quite effective improving the accuracy of the base classifier as well as basic bagging classifier in a situation when bagging fails sometimes to do so.

## 1. INTRODUCTION

In matters of great importance that have financial, medical, social, or other implications, we often seek a second opinion before making a decision, sometimes a third, and sometimes many more. In doing so, we weigh the individual opinions, and combine them through some thought process to reach a final decision that is presumably the most informed one.

The process of consulting “several experts” before making a final decision is perhaps second nature to us; yet, the extensive benefits of such a process in automated decision making applications have only recently been discovered by computational intelligence community.

Also known under various other names, such as multiple classifier systems, committee of classifiers, or mixture of experts, ensemble based systems [2][3] have shown to produce favorable results compared to those of single-expert systems for a broad range of applications and under a variety of scenarios. Popular ensemble based algorithms, such as bagging, boosting, stacked generalization, and hierarchical mixture of experts.

A supervised machine learning task involves constructing a mapping from input data (normally described by several features) to the appropriate outputs. In a classification learning task, each output is one or more classes to which the input belongs. The goal of classification learning is to develop a model that separates the data into the different classes, with the aim of classifying new examples in the future.

Given a new example, the ensemble passes it to each of its multiple *base* models, obtains their predictions, and then combines them in some appropriate manner (e.g., averaging or voting).

## 4. CONCEPT OF BOOTSTRAPPING

Bootstrap is sampling with replacement from a sample. Bootstrapping is the practice of estimating properties of an estimator (such as its variance) by assuming set of observations to be from an independent and identically distributed population, this can be implemented by constructing a number of resamples of the observed dataset (and of equal size to the observed dataset), each of which is obtained by random sampling with replacement from the original dataset. It may also be used for constructing hypothesis tests. The advantage of bootstrapping over analytical methods is its great simplicity.

MCS is a meta-algorithm uses bootstrapping to improve machine learning of classification and regression models in terms of stability and classification accuracy.

### 3. CLASSIFIERS

Classification is a data mining (machine learning) technique used to predict group membership for data instances. Classification and prediction are two forms of data analysis that can be used to extract models describing important data classes or to predict future data trends for which the classifiers are used.

Basically two types of classifiers: Stable and Unstable. The most popular and commonly used stable classifiers are – Fisher Linear Discriminant (FLD) and Nearest Mean Classifier (NMC), and unstable are – Decision Tree, Decision Stumps [5]. MCS uses C4.5 Decision Tree Classifier as a base.

### 4. ENSEMBLE SYSTEM

An ensemble method for classification tasks constructs a set of base classifiers from the training data and performs classification by taking a vote on the prediction of each base classifier. Many traditional machine learning algorithms generate a single model (e.g., a decision tree or neural network). Ensemble learning methods instead generate multiple models.

#### 4.1 Reasons for using Ensemble Based System

There are several theoretical and practical reasons why we may prefer an ensemble system:

##### Statistical Reasons:

A set of classifiers with similar training performances may have different generalization performances. In fact, even classifiers with similar generalization performances may perform differently in the field.

##### Large Volumes of Data:

In certain applications, the amount of data to be analyzed can be too large to be effectively handled by a single classifier. Partitioning the data into smaller subsets, training different classifiers with different partitions of data and combining their outputs using an intelligent combination rule often proves to be a more efficient approach.

##### Too Little Data:

In the absence of adequate training data, resampling techniques can be used for drawing overlapping random subsets of the available data, each of which can be used to train a different classifier, creating the ensemble. Such approaches have also proven to be very effective.

##### Divide and Conquer:

Regardless of the amount of available data, certain problems are just too difficult for a given classifier to solve. More specifically, the decision boundary [3] that separates data from different classes may be too complex, or lie outside the space of functions that can be implemented by the chosen classifier model.

#### 4.2 Diversity

If we had access to a classifier with perfect generalization performance, there would be no need to resort to ensemble techniques. The realities of noise, outliers and overlapping data distributions, however, make such a classifier an impossible proposition. At best, we can hope for classifiers that correctly classify the field data *most of the time*. The strategy in ensemble systems is therefore to create many classifiers, and combine their outputs such that the combination improves upon the performance of a single classifier. This requires,

however, that individual classifiers make errors on different instances. The intuition is that if each classifier makes different errors, then a strategic combination of these classifiers can reduce the total error, a concept not too dissimilar to low pass filtering of the noise. The overarching principle in ensemble systems is therefore to make each classifier as unique as possible, particularly with respect to misclassified instances.

Classifier diversity [3] can be achieved in several ways. The most popular method is to use different training datasets to train individual classifiers. Such datasets are often obtained through resampling techniques, such as bootstrapping or bagging, where training data subsets are drawn randomly, usually with replacement, from the entire training data.

#### 4.3. Creating an Ensemble

Two interrelated questions need to be answered in designing an ensemble system: i) how will individual classifiers (base classifiers) be generated? And ii) how will they differ from each other? The answers ultimately determine the diversity of the classifiers, and hence affect the performance of the overall system.

Therefore, any strategy for generating the ensemble members must seek to improve the ensemble's diversity. In general, however, ensemble algorithms do not attempt to maximize a specific diversity measure. Rather, increased diversity is usually sought—somewhat heuristically—through various resampling procedures or selection of different training parameters. The above defined diversity measures can then be used to compare the diversities of the ensembles generated by different algorithms.

### 5. BAGGING METHOD

In data mining, a model generated by machine learning can be regarded as an expert. Expert is probably too strong a word – Depending on the amount and quality of the training data, and whether the learning algorithm is appropriate to the problem. An obvious approach to making decisions more reliable is to combine the output of different models. Several machine learning techniques do this by learning ensemble of models and using them in combination: prominent among these are schemes called bagging, boosting, and stacking. All are used to increase the predictive performance over a single model. And they are general techniques that can be applied to numeric prediction problems and to classification tasks [1].

The simplest way to do this in the case of the classification is to take the vote (majority vote); in the case of numeric prediction, it is calculating the average vote. So Bagging uses majority voting (for classification) or averaging (for numeric prediction) to combine the output of individual models.

Bagging is a statistical re-sample and combining technique used to reduce the misclassification error of a base classifier. It is based on *bootstrapping and aggregating* techniques.

## 6. BAGGING ALGORITHM

Input:

- D, a set of d training tuples;
- K, the number of models in the ensemble;
- A learning scheme (e.g. decision tree algorithm, back propagation, etc.)

Output: A composite model,  $M^*$ .

Method:

- for  $i = 1$  to  $k$  do // create  $k$  models
- create bootstrap sample,  $D_i$ , by sampling  $D$  with replacement;
- use  $D_i$  to derive a model,  $M_i$ ;
- endfor;

To use the composite model on a tuple,  $X$ :

- if classification then
- let each of the  $k$  models classify  $X$  and return the majority vote;
- if prediction then
- let each of the  $k$  models predict a value for  $X$  and return the average predicted value.

**Fig. 1. The Bagging Algorithm**

Given a set,  $D$ , of  $d$  tuples, bagging works as follows. For iteration  $i$ , ( $i = 1, 2, \dots, k$ ), a training set,  $D_i$ , of  $d$  tuples is sampled with replacement from the original set of  $D$  tuples,  $D$ . Note that the term Bagging stands for *bootstrap aggregation*. Each training set is a bootstrap sample. To classify an unknown tuple  $X$ , each classifier,  $M_i$ , returns its class prediction, which counts as one vote. The bagged classifier,  $M^*$ , counts the votes and assigns the class with the most votes to  $X$ . Bagging can be applied to the prediction for a given test tuple. The algorithm is summarized in the fig. 4.6. The increased accuracy occurs because the composite model reduces the variance of the individual classifiers.

Although the bagging algorithm has been known to be known in increasing the accuracy of prediction of the base unstable classifiers constructing bootstrap samples from training sets and then aggregating to form a final predictor, the main problem with this method is that *there is no guarantee that bagging will improve the performance of any base classifier every time* [1]. The other problem may arise when there is a large dataset of training tuples are there, in that case bagging would not be much effective.

## 7. MCS ALGORITHM

MCS is a modified bagging algorithm using C4.5 as a base classifier, aggregating the models discarding the classifier generating weak result.

The bootstrapping and aggregating is in following way.

- Input:**
- 1) A set of training tuples
  - 2) The number of models (bootstrap) in the ensemble
  - 3) A learning scheme (Decision Tree here)

**Output:** A composite model

**Method:**

- (1) Initialization of the training set & testing set from given data set.
- (2) Apply training data to the base learning, generate a model and calculate accuracy ( $ACC_{base}$ )
- (3) Repeat for number of times (as number of bootstrap)
  - (a) Create bootstrap sample, by sampling with replacement the original training set.
  - (b) Apply base learner on each bootstrap and calculate accuracy, ( $ACC_{boot}$ ).
  - (c) Compare  $ACC_{boot}$  with  $ACC_{base}$
  - (d) If  $ACC_{base} < ACC_{boot}$ 
    - (i) Consider base model as bootstrap model else
    - (ii) Consider bootstrap model
- (4) Calculate majority voting for classification and average accuracy for prediction

**Fig. 2. The MCS Algorithm**

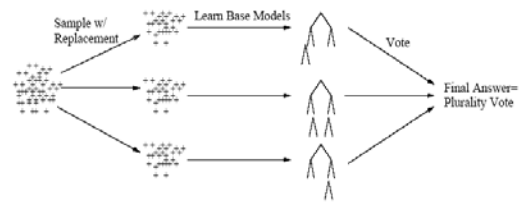

**Figure 3 The figurative view of the MCS algorithm**

The dataset is taken, and then it is divided into training set and testing set according to holdout method in which 2/3 of the set is taken as the training set and remaining 1/3 used as a testing set. Select the base learner classifier (here D.T.C4.5) and apply training data and calculate accuracy, which is called  $ACC_{base}$ .

Create number of bootstraps by doing sample with replacement method on the original training set. Take one bootstrap and apply base learner on it and generate accuracy,  $ACC_{boot}$ . Do this process for each of the bootstraps.

Now compare  $ACC_{boot}$  with  $ACC_{base}$ . If the accuracy of the bootstrap model is less than the accuracy of the base model, then at particular time the accuracy of the base model will be considered as a model for final decision, else the accuracy of the bootstrap model will be considered.

Calculate the majority voting method for better classification and aggregating for prediction.

## 8. EXPERIMENTS AND RESULTS

To evaluate the performance of the MCS we are using five of the well known UCI (University of California Irvine). The performance of the classification-based method is affected by several factors such as the number of records, the number of attributes, the number of records on which model is built, number of bootstraps etc.

Table 1 describes the six different UCI datasets with number of instances that we have used for performance study.

Dataset	No of Instances
Credit-G	1000
Optdigits	5620
Weather	13918

Ecoli	20502
Adult	32561
Wisconsin	65156

**Table 1. Summary of datasets**

Table 2 describes the comparison between Bagging and MCS with C 4.5 as a base classifier. We can see that the accuracy is incremented in case of MCS.

Dataset	Bagging with C4.5 (%)	MCS
Credit-G	74.05	82.05
Optdigits	93.92	94.56
Weather	90.57	91.20
Ecoli	87.93	88.10
Adult	79.21	82.27
Wisconsin	95.04	95.10

**Table 2. Accuracy performance (Bagging Vs MCM)**

We have also compared Bagging and MSC with all the datasets using REPTree and Decision Stumps as base classifiers. In all the comparison we got improved results in MSC then in Bagging.

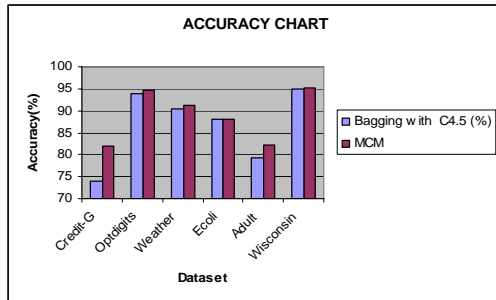

**Figure 3. Comparison of Bagging and MCS (Multiple Classifier System) using WEKA tool. The x-coordinates shows different datasets, y-coordinates shows accuracy in percentage.**

So, we can say that because of the instability of the base classifier, Bagging may fail to improve performance of base classifier, also bagging may work deterioratically in some large benchmark datasets as well. In that situation MCS may help to improve that.

## 9. CONCLUSION

This paper comprehensively shows the comparison between MCS algorithm and Bagging using C4.5 as a base classifier. Due to the instability of the base classifiers (i.e. Decision Tree C4.5), there is no guarantee that bagging will improve the performance of the base classifier every time. MCS eliminates the limitations of Bagging on benchmark datasets and improves the accuracy.

## 10. REFERENCES

- [1] BREIMAN, L., "Bagging Predictors", Technical Report 421, Department of Statistics, University of California, Berkeley.1994
- [2] David Opitz, Richard Maclin (1999). "Popular Ensemble Methods: An Empirical Study". Journal of Artificial Intelligence Research 11 (1999) 169-198.
- [3] ROBI POLIKAR, "Ensemble based system in decision making", IEEE Circuits and system magazine, Third Quarter, 2006.
- [4] Nikunj C. Oza, (2004). "Ensemble Data Mining Methods".
- [5] FAISAL ZAMAN, "A Robust Method Using Median as a Combination Rule", IEEE 8<sup>th</sup> international conference, DOI 10.1109, IT workshop 56,
- [6] J. R. Quinlan, (2006). "Bagging, Boosting, and C4.5".
- [7] KRISTINANA MACHOVA, FRANTISEK BARCAV, PETER BENDAR, "A bagging method using Decision Tree in the role of base classifiers", technical University, Letna, 2006
- [8] GIORGIO FUMERA, Member, "A theoretical analysis of bagging as a linear combination of classifiers", IEEE, and Alessandra Serrau,2008
- [9] Machine learning UCI dataset repository <http://www.ics.uci.edu/mllearn/MLRepository.html>

# EMISSION SCENARIO AT ROAD INTERSECTIONS : A CASE STUDY OF SURAT CITY

Asst.Prof Jayesh A. Shah, Principal Dr. F.S.Umrigar, Ast.Prof Dr L.B.Zala, Ast.Prof Neeraj D.Sharma  
V.B.T.Engg.College , Umrah  
B.V.M Engg. College , V.Vidyanagar

***ABSTRACT:-Indian urban areas are experiencing drastic growth in vehicular population due to most classical reasons of speedy industrialization and urbanization growth . Upshots of such growth are delay and increase traffic congestion on roads, up surging of travel time and fatal accidents and beyond all these the most objectionable issue of increasing pollution levels in urban bases. This paper is an attempt to focus on the pollution level on some of the significant intersections of Surat city in Gujarat.***

## INTRODUCTION

The tremendous increase in mobilization of human society has resulted in phenomenal rise in vehicular traffic on the major roadways. The vehicles discharge an appreciable amount of exhaust emission, which consist of poisonous gases like carbon monoxide, sulphur dioxide, oxides of nitrogen etc. The emission from the vehicles cause adverse effects on plants ,human beings, animals, soil and other environmental components, However every urban area dominance some significant points, regions, stretches of traffic with heavy air pollution and the road intersections are the most critical locations in urban region ,where air pollution is at predominant stage. Presently world survey points out that many developed urban regions are under the influence of air pollution due to vehicular population and many of them have reported the major level of such emission at traffic road intersections due to one or another reasons which may be due to improper practice

of maintaining vehicles , improper operation , old age vehicles , unrealistic design of road intersections or lacking or signalized intersection etc. ,Among these

many cities , megacities , towns of India are facing nastiest scenario at various temporal stages during the year.

The present study is carried out at Surat city which is considered as one of the most developed city of Gujarat state in India. However due to fast development and expansion of city Surat is also experiencing the classical issues of urban transportation like traffic congestion , traffic delay and the most crucial issue of urban air pollution. Here efforts are carried out to recognize most air pollution stimulating traffic intersections in the city and traffic volume surveys alongwith mission survey for CO and HC pollutants have been conducted at some of such intersections during some peak duration.

## MATERIAL AND METHODS

Primarily on the base of present scenario of city traffic as well data of RTO-Surat & Surat Municipal Corporation (SMC) city area is classified on the base of primary and secondary traffic intersections where air pollution fluctuates, however during such classification it is taken care that same categories of intersections are grouped in same group .(*This identification of road intersections includes only intense pollution prone intersections, so not all intersections of city are included and it is also to be noted that survey work is carried out only at some of the following intersections till, remaining is under progress-Some more intersections may be identified at later stage of survey*). Such categories of road intersections are defined on the base of traffic density, use of such intersections during day and night, average pollution level ,traffic delay on such intersection etc. According to this two categories of road intersections , i.e primary and secondary are designated under this survey.(List of existing intersections under these categories are listed in Table-1 ).Mixed traffic conditions were observed during survey work at peak and slack timings.

**Table-1 Identified Primary Intersections**

<b>Sr No</b>	<b>Name of Intersection</b>	<b>Assigned Id</b>	<b>Type of Intersection</b>	<b>Name of Road</b>
1	Gujarat Gas Circle	P1	Four arm Signalized roundabout	Hazira Road
2	Palanpur Patia	P2	T-Type signalized	Rander Road
3	Sona Restaurant	P3	Four arm signalized	Rander Road
4	Navyug College	P4	Four arm staggered signalized	Rander Road
5	Sargam Shoping Centre	P5	Four arm staggered Signalized	Dumas Road
6	Chopati	P6	T-Type signalized	Dumas Road
7	Athwagate flyover bridge	P7	Four arm staggered signalized	Dumas Road-Ring Road
8	Majura Gate Circle	P8	Four arm staggered signalized	Ring Road
9	Chowk Circle	P9	Four arm signalized	Stn Road
10	Sahara Darwaja	P10	T-Type staggered signalized	Ring Road
11	Delhi Gate	P11	Four arm signalized	Stn Road

**Table-2 Identified Secondary Intersections**

<b>Sr No</b>	<b>Name of Intersection</b>	<b>Assigned Id</b>	<b>Type of Intersection</b>	<b>Name of Road</b>
1	Choksi wadi	S1	T-Type signalized	Kadvapatidarwadi Arterial Road
2	Bhulka Bhavan	S2	T-Type signalized	Hazira Road
3	Rishabh Circle	S3	Four arm signalized	Rander Road
5	Bhagal Circle	S4	Four arm Signalized	Stn Road



### Sample Collection & Analysis

Among all identified intersections survey was carried out at two primary intersections (Chowk Circle and Gujarat Gas Circle) where parameters of CO and HC were measured with CO-HC Analyzer PEA 205-Indus auto exhaust monitor gas analyzer from vehicles under idling engine conditions. Both these gases are detected by Non dispersive infrared(NDIR) method. The instrument measure CO in percentage and HC in ppm in the stream of exhaust gas. The analyzer uses the principle of non dispersive infrared technique for measurement. By the consideration of study point of view random sampling was carried out from the fleet of the traffic

flow ,however Surat Traffic police supported during such survey. 1000 Nos. of 2 -Wheelers ,500 Nos. of 3-Wheelers Petrol vehicles samples selected for survey work. Age of vehicle has been considered as significant variable for the analysis part.

### RESULTS AND DISCUSSION

Average emission levels of CO and HC using CO-HC analyzer at both the intersections are tabulated in Table 2 and its graphical presentation is shown in Figure-1

**Table 2: Average CO and HC Emission**

Vehicles	Age (years)	Type of Engine/Ignition	Samples Taken for Survey	Average Emission	
				CO (%)	HC(ppm)
3-Wheelers	More than 10	2 Stroke	90	3.9	6750
3-Wheelers	More than 10	4 stroke	10	3.48	5875
2-Wheelers	More than 10	2 Stroke	100	3.55	6680
2-Wheelers	More than 10	4 stroke	150	3.22	4672
3-Wheelers	Less than 10	2 Stroke	250	3.12	4880
3-Wheelers	Less than 10	4 stroke	150	2.88	3660
2-Wheelers	Less than 10	2 Stroke	350	2.90	4518
2-Wheelers	Less than 10	4 stroke	400	2.32	3050

**\* Combined includes two and four stroke engine for 2 Wheelers**

Above results at two selected intersections indicates that comparatively 3-Wheelers contributes more concentration of Carbon Monoxide and Hydrocarbons to the environment and also the contribution of such parameters are more from 2 Stroke vehicles than 4 Stroke Vehicles.

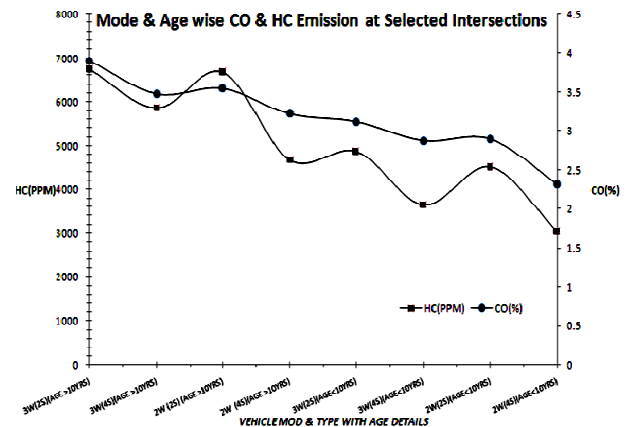

**Figure-1 Chart Representing the CO & HC Emission scenario at Selected Intersections of Surat City**

## FUTURE WORK

Above scenario represents the need of detail survey at another intersections and model study of vehicular exhaust emission, However such thing can be carried out with conventional way of stastical modeling approach but with the modern trend of research has now opened the research prospects with geospatial base where numerous factors can be considered simultaneously for modeling analysis of pollutant emission at respective geo referenced locations. GIS and GPS are the best modeling tools and analytical approach for this. Multi decision making can also be incorporate with the introduction of GIS and GPS study of identified intersections. So in such regard these two and other road intersections are planned to map with GPS and configured with GIS for detailed analysis of pollutant behaviour at typical intersection and it can be easily verified by implementing the model at same type and same traffic patterned intersection.

## CONCLUSION

As from the obtained results it appears that Old aged vehicles are prone to cause much emission of CO and HC than the new i.e (having the age less than 10 years) and also 2 Strokes vehicles are found with more concentration of CO and HC than 4 Stroke. It is interested to note that despite of same type vehicles(i.e-2 stroke or 4-stroke) emission was found different due to vehicular age factor, adulteration of fuel, etc. Such factors should be analyzed simultaneously to get more concrete outcome of the modeling study to be carried out at said intersection. However in present case study survey was preliminary level survey but detail survey with more parameters and by incorporating seasonal variations is required to create geospatial model for the air pollution study at these and other remaining primary and secondary road intersections.

## REFERENCES

1. Bandopadhyay S.N., "Automobile Air Pollution and its control, Indian Highways, 1996
2. Dr. Satu Kush, "Automobile Pollution", 1<sup>st</sup> ed., IVY Publishing House, Delhi, 2001.
3. Hayashi & Roy(1995),"Transport Land use and Environment" Kluwer, Boston
4. Rao C.S(2001), " Environmental Pollution Control Engineering", New Age International Pvt. Ltd., New Delhi
5. S.Vijay Kumar,"Traffic and transport impact on Environment-An Overview",Feb-1997
6. Sharma N.D (2003),,"Vehicular Pollution Growth:- A Trend of Surat City", *Proc., Urban Air Pollution :Issues & Management* ,National Conference at SVNIT –Surat ,pp-2-76
7. Tailor R.(2002),,"Metropolitan Travel Behaviour Analysis: A Case study of Surat City". *MTRP Dissertation*, SVNIT, Surat
8. Umrigar F.S., (2003)"Urban Transport Plan-Let us Move Urbanities-Not Automobiles:," *Journal of Engineering & Technology, Sardar Patel University*, Vol-16-pp-II-III

# Performance Comparison of Space Time Codes

Anshu Shah, Asst Prof. Gandhinagar Institute of Technology, Gandhinagar  
M. Salim, Asst Prof, MNIT, Jaipur  
Prof. R.P. Yadav, MNIT, Jaipur

**Abstract:** Space-time coding is a technique used in wireless communications to transmit multiple copies of a data stream across a number of antennas and to exploit the various received versions of the data to improve the reliability of data-transfer. The fact that transmitted data must traverse a potentially difficult environment with scattering, reflection, refraction and so on as well as be corrupted by thermal noise in the receiver means that some of the received copies of the data will be 'better' than others. This redundancy results in a higher chance of being able to use one or more of the received copies of the data to correctly decode the received signal. In fact, space-time coding combines all the copies of the received signal in an optimal way to extract as much information from each of them as possible. This paper presents performance evaluation of concatenated Space Time code in Rayleigh Fading environment. This code uses Space Time Trellis Code as Outer code and space Time Block Code as inner code. Hence providing advantage of diversity of STBC along with STTC's decoding advantage

## Section-1

### Space Time Block Codes: Introduction

In the case of STBC in particular, the data stream to be transmitted is encoded in blocks, which are distributed among spaced antennas and across time. While it is necessary to have multiple transmit antennas, it is not necessary to have multiple receive antennas, although to do so improves performance [1]. This process of receiving diverse copies of the data is known as diversity reception and is what was largely studied until Foschini's 1998 paper.

An STBC is usually represented by a matrix. Each row represents a time slot and each column represents one antenna's transmissions over time.

#### A. Alamouti scheme with two transmitter one receiver [2]

The scheme uses two transmit antennas and one receive antenna and may be defined by the following three functions:

- The encoding and transmission sequence of information symbols at the transmitter;
- The combining scheme at the receiver;
- The decision rule for maximum likelihood detection.

**1) The Encoding and Transmission Sequence:** At a given symbol period, two signals are simultaneously transmitted from the two antennas. The signal transmitted from antenna zero is denoted by  $s_0$  and from antenna one by  $s_1$ . During the next symbol period signal  $(-s_1^*)$  is transmitted from antenna zero, and signal  $s_0^*$  is transmitted from antenna one where  $*$  is the complex conjugate operation. This sequence is shown in Table I.

	TX ant0	TX ant1
Time t	$s_0$	$s_1$
Time t+T	$-s_1^*$	$s_0^*$

**Table 1: the notation for the transmitted signals at the two transmit antennas**

Here encodings is done in space and time. The channel at a time t is modeled by a complex multiplicative distortion  $h_0(t)$  for transmit antenna 1 and  $h_1(t)$  for transmit antenna 2. We assume that the fading is constant across 2 consecutive symbols .

$$h_0(t) = h_0(t + T) = \alpha_0 e^{j\theta} ; h_1(t) = h_1(t + T) = \alpha_1 e^{j\theta} \quad (1)$$

where T is the symbol duration. The Receiver symbols can now be expressed as

$$r_0(t) = r_0(t + T) = h_0 s_0 + h_1 s_1 + n_0$$

$$r_1(t) = r_1(t + T) = -h_0 s_1^* + h_1 s_0^* + n_1 \quad (2)$$

Where  $r_0$  and  $r_1$  are received signals at a time t and t+T and  $n_0$  and  $n_1$  are complex random variable representing receiver noise and interference. Received signal  $r_0$  consist of signals  $s_0$  and  $s_1$  and received signal  $r_1$  consist of the conjugate  $s_1^*$  and  $s_0^*$ . To determine the transmitted signals, we have to uncouple the 2 equations and extract out measures of the transmitted signals from these equations. This is done in the combiner the combiner is associated by the channel estimator which provides perfect estimation of the channel parameters.

The main advantages of the Alamouti scheme is that simple signal processing is performed to separate the signals  $s_0$  and  $s_1$  respectively the estimates of the transmitted signals are formed as

$$\tilde{s}_0 = h_0^* r_0 + h_1 r_1^*$$

$$\tilde{s}_1 = h_1^* r_0 - h_0 r_1^* \quad (3)$$

so after solving the equations results obtained

$$\begin{aligned} s_0 \sim & (\alpha_0^2 + \alpha_1^2) s_0 + h_0^* n_0 + h_1 n_1^* \\ s_1 \sim & (\alpha_0^2 + \alpha_1^2) s_1 - h_0 n_1^* + h_1^* n_0 \end{aligned} \quad (4)$$

The maximum likelihood decoder must now yield the symbols transmitted over two symbol interval. For the case of PSK the decision rule can be simplified to,

Decide in the favor of signal point  $s_i$  if

$$d^2(s_0 \sim, s_i) \leq d^2(s_0 \sim, s_k) \quad \text{such that } i \neq k.$$

A similar rule can be stated for receiver estimate  $s_i \sim$  also

Decide in the favor of signal point  $s_j$  if

$$d^2(s_1 \sim, s_j) \leq d^2(s_1 \sim, s_k) \quad \text{such that } j \neq k$$

if the similar signal is received by two antennas then the decoder equation will be:

$$s_0 \sim = h_0^* r_0 + h_1 r_1^* + h_2^* r_2 + h_3 r_3^*$$

$$\Rightarrow s_0 \sim = (\alpha_0^2 + \alpha_1^2 + \alpha_2^2 + \alpha_3^2) s_0 + h_0^* n_0 + h_1 n_1^* + h_2^* n_2 + h_3^* n_3$$

$$s_1 \sim = h_1^* r_0 - h_0 r_1^* - h_2^* r_3 + h_3 r_2^*$$

$$s_1 \sim = (\alpha_0^2 + \alpha_1^2 + \alpha_2^2 + \alpha_3^2) s_1 + h_1^* n_0 - h_0 n_1^* + h_3^* n_2 - h_2 n_3^*$$

**Table 2- the definition of channels between the transmit and receive antennas**

	RX ant0	Rx ant 1
TX ant 0	$h_0$	$h_2$
TX ant 1	$h_1$	$h_3$

And

**Table 3 -the notation for the received signals at the two receive antennas**

	RX ant0	Rx ant 1
Time t	$r_0$	$r_2$
Time T+t	$r_1$	$r_3$

	TX ant0	TX ant1
Time t	$s_0$	$s_1$
Time t+T	$-s_1^*$	$s_0^*$

The recovered signal are then applied to ML detector, which works in he similar fashion stated above.

### Higher order STBCs

Tarokh et al. discovered a set of STBCs [3][4] that are particularly straightforward, and coined the scheme's name. They also proved that no code for more than 2 transmit antennas could achieve full-rate. Their codes have since been improved upon (both by the original authors and by many others). Nevertheless, they serve as clear examples of why the rate cannot reach 1, and what other problems must be solved to produce 'good' STBCs. They also demonstrated the simple, linear decoding scheme that goes with their codes under perfect channel state information assumption.

$$C_{3,1/2} = \begin{bmatrix} s_1 & s_2 & s_3 \\ -s_2 & s_1 & s_4 \\ -s_3 & s_4 & s_1 \\ -s_4 & -s_3 & s_2 \\ s_1^* & s_2^* & s_3^* \\ -s_2^* & s_1^* & s_4^* \\ -s_3^* & s_4^* & s_1^* \\ -s_4^* & -s_3^* & s_2^* \end{bmatrix} \quad \text{and} \quad C_{3,3/4} = \begin{bmatrix} s_1 & s_2 & \frac{s_3}{\sqrt{2}} \\ -s_2^* & s_1^* & \frac{s_4}{\sqrt{2}} \\ \frac{s_3^*}{\sqrt{2}} & \frac{s_4^*}{\sqrt{2}} & \frac{(-s_1 - s_1^* + s_2 - s_2^*)}{2} \\ \frac{s_3^*}{\sqrt{2}} & -\frac{s_4^*}{\sqrt{2}} & \frac{(s_2 + s_2^* + s_1 - s_1^*)}{2} \end{bmatrix}$$

$$C_{4,1/2} = \begin{bmatrix} s_1 & s_2 & s_3 & s_4 \\ -s_2 & s_1 & s_4 & s_3 \\ -s_3 & s_4 & s_1 & -s_2 \\ -s_4 & -s_3 & s_2 & s_1 \\ s_1^* & s_2^* & s_3^* & s_4^* \\ -s_2^* & s_1^* & s_4^* & s_3^* \\ -s_3^* & s_4^* & s_1^* & -s_2^* \\ -s_4^* & -s_3^* & s_2^* & s_1^* \end{bmatrix} \quad \text{and} \quad C_{4,3/4} = \begin{bmatrix} s_1 & s_2 & \frac{s_3}{\sqrt{2}} & \frac{s_4}{\sqrt{2}} \\ -s_2^* & s_1^* & \frac{s_4}{\sqrt{2}} & -\frac{s_3}{\sqrt{2}} \\ \frac{s_3^*}{\sqrt{2}} & \frac{s_4^*}{\sqrt{2}} & \frac{(-s_1 - s_1^* + s_2 - s_2^*)}{2} & \frac{(-s_2 - s_2^* + s_1 - s_1^*)}{2} \\ \frac{s_3^*}{\sqrt{2}} & -\frac{s_4^*}{\sqrt{2}} & \frac{(s_2 + s_2^* + s_1 - s_1^*)}{2} & -\frac{(s_1 + s_1^* + s_2 - s_2^*)}{2} \end{bmatrix}$$

### Simulation Results:

#### Assumptions:

1. Receiver has Perfect Knowledge of channel.
2. Channel is assumed to be Rayleigh with zero mean and unity variance.
3. Frame size is taken as 8 bits.

Under the aforementioned assumptions simulation is done using MATLAB. The simulation results are shown below for Alamouti scheme applied on the following and the results are also shown for them respectively:

1. 2 transmitter and 1 receiver system using BPSK constellation
2. 2 transmitter and 2 receiver scheme using BPSK constellation
3. 2 Transmitter and 2 receiver scheme using QPSK constellation.

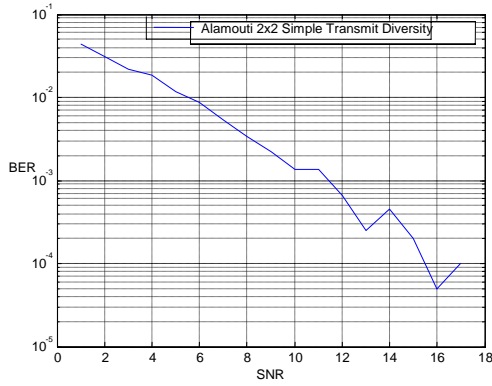

Fig 1: 2 transmitter and 1 receiver system using BPSK constellation

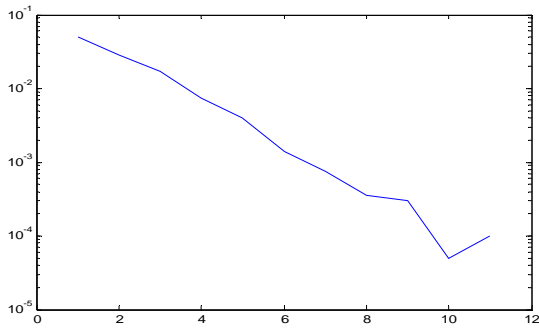

Fig 2: 2 transmitter and 2 receiver scheme using BPSK constellation

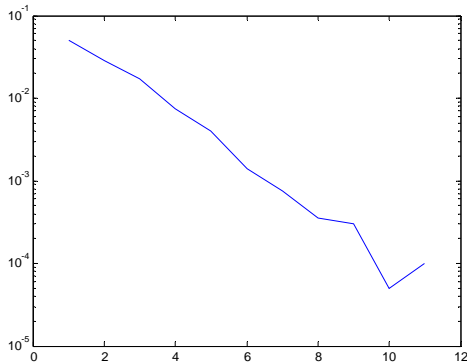

Fig.3: 2 Transmitter and 2 receiver scheme using QPSK constellation

It can be seen from the BER characteristics that with the Alamouti Scheme good error performance can be achieved at lower SNR. The BER performance is independent of modulation used so using this scheme even a lower complexity modulation system can perform better. Improvement in Performance can be achieved using diversity. i.e. the system performance can be increased significantly by increasing the number of transmitting and receiving antennas.

## Section II

### 1) Space Time Trellis Codes: Introduction

Space-Time Coding (STC) is an open loop transmission scheme that was introduced by V. Tarokh[5]. In STC, joint design of channel coding and modulation is done to create efficient transmission techniques which improve system performance by providing both the diversity advantage of multiple transmit antennas and coding gain. In [5], space-time codes based on trellis-coded modulation (TCM) are presented. These codes are called Space-Time Trellis Codes (STTC) and their performance was shown to be very good in slow Rayleigh fading environments. The receiver for these STTC schemes uses Maximum Likelihood Sequence Estimation (MLSE) and the decoding complexity for these schemes (measured in terms of number of trellis states) increases exponentially with transmission rate for a fixed number of transmit antennas.

Space-time trellis codes (STTC) are a type of space-time code used in multiple-antenna wireless communications. This scheme transmits multiple, redundant copies of a trellis (or convolutional) code distributed over time and a number of antennas ('space'). These multiple, 'diverse' copies of the data are used by the receiver to attempt to reconstruct the actual transmitted data. For a STC to be used, there must necessarily be multiple *transmit* antennas, but only a single *receive* antennas is required; nevertheless multiple receive antennas are often used since the performance of the system is improved by so doing.

In contrast to space-time block codes (STBCs), they are able to provide both coding gain and diversity gain and have a better bit-error rate performance. However, being based on trellis codes, they are more complex than STBCs to encode and decode; they rely on a Viterbi decoder at the receiver where STBCs need only linear processing [5].

Space-Time block codes can achieve a maximum possible diversity advantage with a simple decoding algorithm. It is very attractive because of its simplicity. However, no coding gain can be provided by space-time block codes, while non-full rate space-time block codes can introduce bandwidth expansion[7]. STTC was first introduced by Tarokh, Seshadri and Calderbank [4]. It was widely discussed and explored in the literature as STTC can simultaneously offer a substantial coding gain, spectral efficiency, and diversity improvement on flat fading channels.

### B. Encoder Structure for STTC

For space-time trellis codes, the encoder maps binary data to modulation symbols, where the mapping function is described by a trellis diagram. Let us consider an encoder of space-time trellis coded M-PSK modulation with  $n_T$  transmit antennas as shown in Fig.1[6].

The input message stream, denoted by  $c$ , is given by[6]

$$c = (c_0, c_1, c_2, \dots, c_t) \quad (3.1)$$

where  $c_t$  is a group of  $m = \log_2 M$  information bits at time  $t$  and given by

$$c_t = (c_t^1, c_t^2, \dots, c_t^m)$$

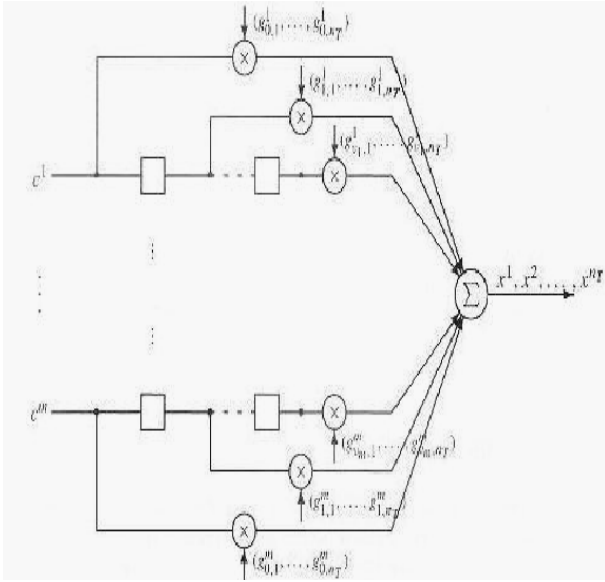

Fig. 4. Encoder for STTC

The encoder maps the input sequence into an M-PSK modulated signal sequence, which

is given by

$$x = (x_0, x_1, \dots, x_t, \dots) \quad (5)$$

where  $x_t$  is a space-time symbol at time  $t$  and given by

$$x_t = (x_t^1, x_t^2, \dots, x_t^{n_T})^T \quad (6)$$

The modulated signals,  $x_t = (x_t^1, x_t^2, \dots, x_t^{n_T})^T$ , are transmitted simultaneously through  $n_T$  transmit antennas.

## Generator Description

In the STTC encoder as shown in Fig.1,  $m$  binary input sequences  $c^1, c^2, \dots, c^m$  are fed into the encoder, which consist of  $m$  feed-forward shift registers. The  $k$ -th input sequence  $c^k = (c_0^k, c_1^k, \dots, c_t^k, \dots)$ , is passed to the  $k$ -th shift register and multiplied by an encoder coefficient set. The multiplier outputs from all shift registers are added modulo  $M$ , giving the encoder output  $x_t = (x_t^1, x_t^2, \dots, x_t^{n_T})^T$ . The connections between the shift register elements and the modulo  $M$  adder can be described by the following  $m$

multiplication coefficient set sequences

$$\begin{aligned} g^1 &= [(g_{0,1}^1, g_{0,2}^1, \dots, g_{0,n_T}^1), (g_{1,1}^1, g_{1,2}^1, \dots, g_{1,n_T}^1), \dots, (g_{t,1}^1, g_{t,2}^1, \dots, g_{t,n_T}^1)] \\ g^2 &= [(g_{0,1}^2, g_{0,2}^2, \dots, g_{0,n_T}^2), (g_{1,1}^2, g_{1,2}^2, \dots, g_{1,n_T}^2), \dots, (g_{t,1}^2, g_{t,2}^2, \dots, g_{t,n_T}^2)] \\ &\dots \\ g^m &= [(g_{0,1}^m, g_{0,2}^m, \dots, g_{0,n_T}^m), (g_{1,1}^m, g_{1,2}^m, \dots, g_{1,n_T}^m), \dots, (g_{t,1}^m, g_{t,2}^m, \dots, g_{t,n_T}^m)] \end{aligned} \quad (7)$$

where  $g_{j,i}^k, k = 1, 2, \dots, m, j = 1, 2, \dots, v_k, i = 1, 2, \dots, n_T$  is an element of the M-PSK constellation set, and  $v_k$  is the memory order of the  $k$ -th shift register.

The encoder output at time  $t$  for transmit antenna  $i$ , denoted by  $x_t^i$ , can be computed as

$$x_t^i = \sum_{k=1}^m \sum_{j=0}^{v_k} g_{j,i}^k c_{t-j}^k \text{ mod } M, \quad i = 1, 2, \dots, n_T \quad (8)$$

These outputs are elements of an M-PSK signal set. Modulated signals from the space time symbol transmitted as time  $t$

$$x_t = (x_t^1, x_t^2, \dots, x_t^{n_T})^T \quad (9)$$

The space-time trellis coded M-PSK can achieve a bandwidth efficiency of  $m$  bits/s/Hz.

The total memory order of the encoder, denoted by  $v_k$ , is given by

$$v = \sum_{k=1}^m v_k \quad (10)$$

Where  $U_k$ , is the memory order for the  $k$ -th encoder branch. The value of  $U_k$  for M-PSK constellations is determined by

$$v_k = \lceil v + k - 1 / \log_2 M \rceil \quad (11)$$

The total number of states for the trellis encoder is  $2^v$ . The  $m$  multiplication coefficient set sequences are also called the *generator sequences*, since they can fully describe the encoder structure.

### Decoding

For STTC, the decoder employs the Viterbi algorithm to perform maximum likelihood decoding. Assuming that perfect CSI is available at the receiver, for a branch labeled by  $x_t = (x_t^1, x_t^2, \dots, x_t^{n_r})^T$ , the branch metric is computed as the squared Euclidean distance between the hypothesized received symbols and the actual received signals as

$$\sum_{j=1}^{n_r} |r_t^j - \sum_{i=1}^{n_r} h_{j,i}^t x_t^i|^2$$

The Viterbi algorithm selects the path with the minimum path metric as the decoded sequence.

### Simulation Results:

Assumptions:

1. The generator sequences of a 4-state space-time trellis coded QPSK scheme with 2 transmit antennas are assumed to be:  $g_1=[0 \ 2 \ ; \ 2 \ 0]$  and  $g_2=[0 \ 1 \ ; \ 1 \ 0]$
2. The encoder takes  $m=2$  bits as its input at each time.
3. The trellis consists of  $2^v=4$  states, represented by state nodes.
4. The Channel is assumed to be Rayleigh.
5. The channel is known perfectly at the receiver.

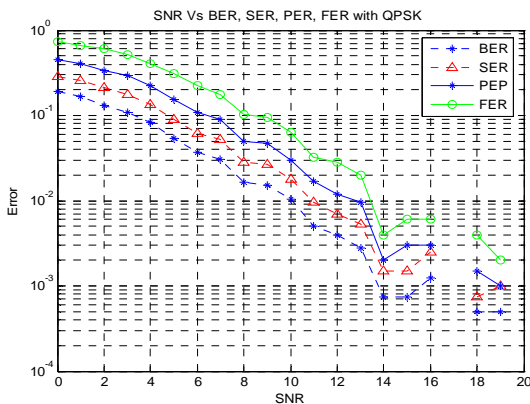

Fig 5: 4-state space-time trellis coded QPSK scheme

From the fig. 5, We can say that Space Time Trellis codes provide improved error performance for wireless systems using multiple antenna. These codes can also provide the full diversity gain as well as coding gain. Performance can be improved by increasing the number of receive antennas but at the cost of increased decoder complexity. Another way to improve performance is either to increase constellation size or opt for higher state STTC.

### Section III

#### Concatenated Space Time Code: Introduction

Concatenation is also frequently employed in space time coded systems. In this case, the outer code is frequently a TCM system whose symbol are transmitted via an inner space time coded system [9][8].

In what follows, we combine space-time block codes with a trellis code to come up with a new structure that guarantees the full diversity with increased rate. Also, we show how to design the trellis code to maximize the coding gain. The result is a systematic method to design space-time trellis codes for any given rate and number of states.

#### The System Model:

The system can be described by the block diagram shown below. Space Time Trellis code is used as outer cod and Space Time Block Codes are used as inner code. The data modulator used in the work is QPSK modulator & channel is assumed to be Rayleigh.

If  $x(t)$  represents the input bit stream &  $s(t)$  is the STTC encoded data, we can model the system as:

$$s(t) = \mathfrak{F}\{x(t)\}_{STTC} \dots \text{i.e. STTC encoding}$$

Here, 4 State STTC is considered and the generator used is the same as was used in STTC encoding.

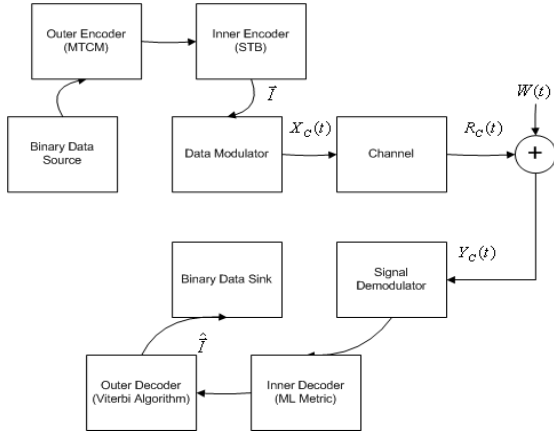

Fig. 6. Proposed system for concatenated encoder and decoder.

$$\tilde{I} = \mathfrak{Z}\{s(t)\}_{STBC} \dots\dots\dots \text{i.e. STBC encoding}$$

The signal  $X_c(t)$  is the 2 bit QPSK modulated signal  $\tilde{I}$ . The QPSK signal may assign any of the four values possible i.e.  $1+i$ ,  $1-i$ ,  $-1+i$  and  $-1-i$ .

The system equation is then written as :

$$Y_c(t) = R_c(t) * X_c(t) + W(t) \quad (12)$$

$Y_c(t)$  &  $W(t)$  are channel response and channel noise(Rayleigh).

**Design of Concatenated code:**

After defining a system, the next problem is how to implement (Alamouti) on encoded STTC codes. For that purpose again consider the STTC encoder. For convenience it is shown below:

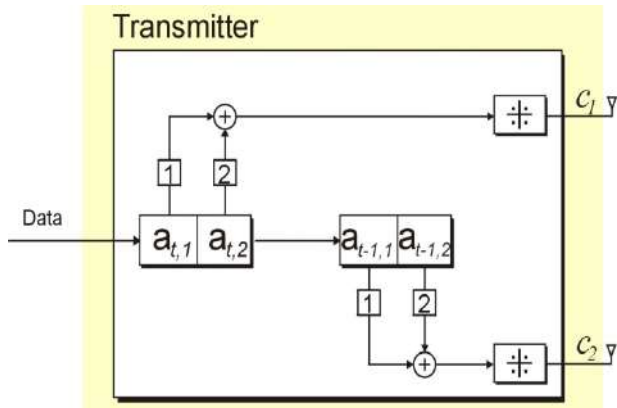

Fig. 7: Encoder for space time trellis code

**Implementation of STBC on encoded STTC:**

In this work, following orthogonal design is used as transmission matrices:

$$C(x_1, x_2) = \begin{pmatrix} x_1 & x_2 \\ -x_2^* & x_1^* \end{pmatrix} \quad (13)$$

Where \* denotes the conjugate operation.

Let the output of the STT encoder  $c_1$  and  $c_2$  are represented as:

$$c_1 = c_t = c_t^1 c_t^2 c_t^3 \dots\dots\dots c_t^n$$

And

$$c_2 = c_{t-1} = c_{t-1}^1 c_{t-1}^2 c_{t-1}^3 \dots\dots\dots c_{t-1}^n \quad (14)$$

The data stream can now be encoded according to Alamouti scheme as

$$\tilde{I}(c_1, c_2) = \begin{pmatrix} c_1 & c_2 \\ -c_2^* & c_1^* \end{pmatrix} \quad (15)$$

In this manner without increasing the number of transmitting antennas significant improvement in the performance can be achieved.

**Decoding:**

Decoder structure for the concatenated code is similar to that used previously for STTC and STBC decoders. Let the received signals at the two receive antennas are  $r_1$  and  $r_2$ , the data can be recovered by applying it first to the STBC decoder and extracting the signals  $c_1$  and  $c_2$  as follows:

$$\begin{aligned} c_1 &= h_0^* r_0 + h_1 r_1^* + h_2^* r_2 + h_3 r_3^* \\ c_2 &= h_1^* r_0 - h_0 r_1^* - h_2^* r_3 + h_3 r_2^* \end{aligned} \quad (16)$$

The recovered data streams are then applied to the Viterbi decoder for further decoding.



## 15 Simulation Results:

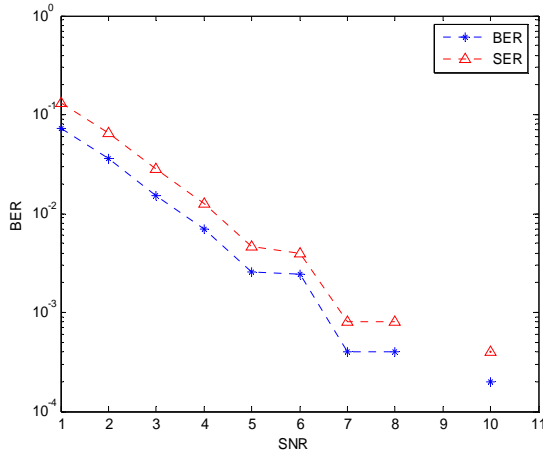

Fig 8: SNR vs BER performance of proposed scheme

For STTC, the decoder employs the Viterbi algorithm to perform maximum likelihood

decoding. Assuming that perfect CSI is available at the receiver, for a branch labeled by

$x_t = (x_t^1, x_t^2, \dots, x_t^{n_T})^T$ , the branch metric is computed as the squared Euclidean distance

between the hypothesized received symbols and the actual received signals as

$$\sum_{j=1}^{n_R} \left| r_t^j - \sum_{i=1}^{n_T} h_{j,i}^t x_t^i \right|^2$$

The Viterbi algorithm selects the path with the minimum path metric as the decoded sequence.

In this work, a simple technique is proposed for designing an improved high-rate space-time code. The proposed design was based on a concatenation of an orthogonal space-time block code and an STTC encoder. A high-rate Concatenated-STTC design was achieved by expanding the cardinality of the space time block code before concatenates it with an outer STTC encoder. Signal orthogonality was exploited to keep decoding complexity of the proposed scheme relatively low.

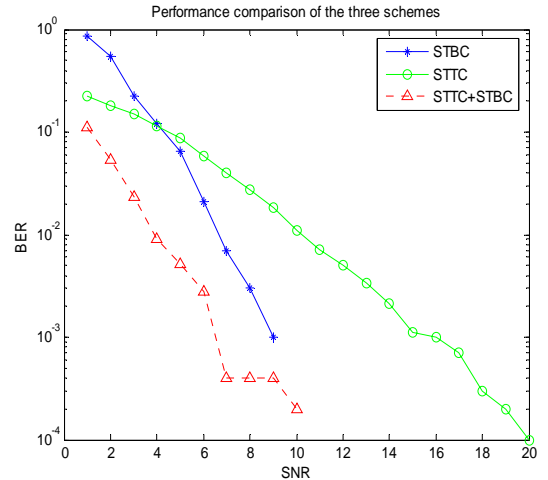

In the above fig. SNR vs. BER performances of three coding techniques using 4 PSK modulation are shown at frame size of 64. We can observe that for an BER of  $10^{-3}$  the required SNR for STBC is 10 dB, for STTC is 17 dB and for concatenated STTC is 7 dB only.

## Section IV

### VII. CONCLUSION

In the thesis work, simulation results are drawn for the three coding schemes namely: Space time Block Codes, Space Time Trellis Codes and Concatenated Space time code where STTC is used as outer code and STBC is used as inner code.

From the simulation results of STBC it can be seen that this code provide performance independent of modulation technique employed. The performance can be further improved by increasing the number of transmit and receive antennas i.e. applying the diversity to this code. The most important point that we can observe is that this code performs with very high efficiency because of orthogonality property under Rayleigh fading environment compared to other codes.

STTC is also simulated and the results are shown in chapter 3 where it has been shown that this code can provide full diversity as well as coding gain. The performance improvement can be achieved by increasing the number of states but it increases receiver complexity. We can also observe that the STTC is sensitive to modulation employed & for getting better performance higher constellation size has to be used [5].

Here, to improve the performance of lower constellation size (we used 4 PSK), Concatenation of STTC with STBC is proposed. The simulation results show that the Concatenated STTC outperforms the two previous methods.

The performance gain that we achieve is at the cost of reduced code rate and increased receiver complexity. If code rate reduction can be tolerated, the proposed scheme shows very good results. Performance can be further improved by increasing the number of transmitting antennas.

*References:*

1. Special Issue on the European Path Toward UMTS, *IEEE Personal Commun. Mag.*, vol. 2, Feb. 1995.
2. Siavash M. Alamouti "A Simple Transmit Diversity Technique for Wireless Communications" *IEEE journal on select areas in communications*, vol. 16, no. 8, october 1998
3. V. Tarokh, H. Jafarkhani, and A.R. Calderbank, "Space time block codes from orthogonal designs", *IEEE Trans. Inform. Theory*, Vol. 45, July 1999.
4. -----," Space time block coding for wireless communication: performance results" *IEEE J. select. Areas commun.* Vol 17, Mar. 1999
5. Vahid Tarokh,, Nambi Seshadri, and A. R. Calderbank, "Space-Time Codes for High Data Rate Wireless Communication: Performance criterion and Code Construction" *IEEE transactions on information theory*, vol. 44, no. 2, march 1998
6. Bahador Amiri "Space-time Trellis codes" thesis.
7. S. Sandhu, R. Heath and Pulraj, " Space time block codes versus space time trellis codes", *ICC* june 2001
8. S. Siwamogsatham and M.P.Fitz, " Improved high rate space time codes via orthogonality and set partitioning",in *proc. IEEE wireless communications and networking conf.* Mar 2002
9. -----, "Improved high rate space time codes via concatenation of expanded orthogonal Block code and M-TCM" in *IEEE ICC* Apr. 2002

# DATA MINING: TERMS AND TECHNIQUES

<sup>1</sup>Mr. Uresh N Parmar, <sup>2</sup>Mr. Krunal G. Patel, <sup>3</sup>Ms. Meenakshi Saroha, <sup>4</sup>Mr. Nishidh S. Chavda

<sup>1,2</sup> Asst. Prof., IT Department, CCET, Wadhwan, Gujarat, India

<sup>3</sup> Lecturer, IT Department, KITRC, Kalol, Gujarat, India

<sup>4</sup> Asst. Prof., CE Department, CIT, Changa, Gujarat, India

ureshparmar13@yahoo.co.in, kgp2003@gmail.com, meenakshi.saroha@gmail.com, nishidhchavda.ce@ecchanga.ac.in

**Abstract:-**Data mining, the extraction of hidden predictive information from large database, is a powerful new technology with great potential to help Companies. Data Mining is the search for the relationships and global patterns that exists in large databases but is 'hidden' among the vast amount of data. Data mining achieves different technical approaches, such as clustering, data summarization, and learning classification rules, finding dependency networks, analyzing and detecting anomalies.

Data mining activities are usually performed by three different classes of users: such as executives, end users and analysts. These users usually perform three types of data mining activity within a corporate environment: episodic, strategic and continuous data mining. Functions available with data mining are classification, clustering, association and many more. It concerned with marketing, insurance, banking and transportation like applications.

Data mining may have problems like uncertainty, missing values, size of the data, data updating and more.

The main objective of this paper is to overcome the brief introduction towards the different terms and next generation techniques of data mining.

## 1. INTRODUCTION

Data mining refers to the Knowledge Discovery in Data bases (KDD). Data mining techniques are identifying nuggets of information or decision making knowledge in bodies of data and extracting these in such a way that they can be put to use classification, prediction, data forecasting and decision making. Data mining is a powerful new technology with great potential to help companies focus on the most important information in their data warehouses.

Data Mining is the search for the relationships and global patterns that exists in large databases but is 'hidden' among the vast amount of data, these relationships represent valuable knowledge about the database and the objects in the database.

Basically data mining is concerned with the analysis of data and the use of software techniques for finding patterns and regularities in sets of data. Data mining analysis process starts with a set of data uses a methodology to develop an optimal representation of the structure of the data during which time knowledge is acquired.

## 1.1 Data mining Architecture

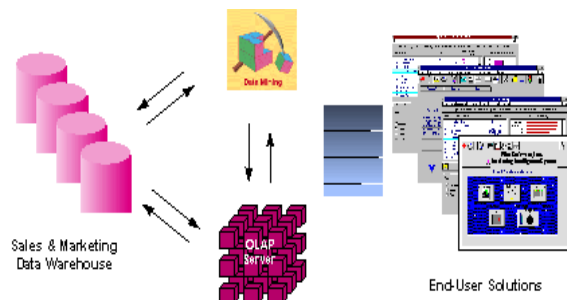

Fig 1. Data mining Architecture

The ideal starting point is a data warehouse containing a combination of internal data tracking all customer contact coupled with external market data about competitor activity. An OLAP (On-Line Analytical Processing) server enables a more sophisticated end-user business model to be applied when navigating the data warehouse [5].

## 2. DATA MINING MODELS

There are two types of model or modes of operation, which may be used to discover information of interest to the user.

### 2.1 Verification Model

The verification model takes input from the user and tests the validity of it against the data. The emphasis is with the user who is responsible for formulating the hypothesis and issuing the query on the data to affirm or negate the hypothesis.

The problem with this model is the fact that no new information is created in the retrieval process but rather the queries will always return records to verify or negate the hypothesis. The user is discovering the facts about the data using a variety of techniques such as queries, multidimensional analysis and visualization to guide the exploration of the data being inspected.

### 2.2 Discovery Model

The discovery model differs in its emphasis in that it is the system automatically discovering important information hidden in the data. The data is sifted in search of frequently occurring patterns, trends and generalizations about the data without intervention or guidance from the user.

### 3. DATA MINING PROCESS

Following are the processes/stages identified in Data Mining and Knowledge Discovery. The phrases depicted start with the raw data and finish with the extracted knowledge, which was acquired as a result of the following stages:

3.1 Data Selection: Examining the entire raw data set identifies the target subset of data and the attributes of interest. This includes selecting or segmenting the data according to some criteria e.g. all those people who own a car, in these way subsets of the data can be determined.

3.2 Data Cleaning: In this step, noise and outliers are removed, field values are transformed to common units and combining existing fields to facilitate analysis creates some new fields. The data is typically put into a relational format, and several tables might be combined in a de normalization step. Also the data is reconfigured to ensure a consistent format as there is a possibility of inconsistent formats because the data is drawn from several sources e.g. sex may recorded as f or m and also as 1 or 0.

3.3 Transformation: The data is not merely transferred across in that overlays may be added such as demographic overlays in the market research. The data is made usable.

3.4 Data mining: This stage is concerned with the extraction of patterns from the data. Data mining algorithms can be applied to extract the interesting patterns of data.

3.4 Interpretation and Visualization: The patterns identified by the system are interpreted into knowledge, which can then be used to support human decision-making e.g. prediction and classification tasks, summarizing the contents of a database or explaining observed phenomena. The patterns are presented to end users in an understandable form, e.g. through visualization[1].

### 4. DATA MINING NEXT GENERATION TECHNIQUES.

Data mining techniques are as follows:

#### 4.1 Cluster Analysis

In an unsupervised learning environment the system has to discover its own classes. We can cluster the data in the database as shown in the Figure 1. The first step is to discover subsets of related objects and then find descriptions e.g. D1, D2, D3 etc., that describe each of these subsets.

**Fig 2. Discovering clusters and descriptions in a database**

by taking the edges, corresponding to the values of the attributes in an object.

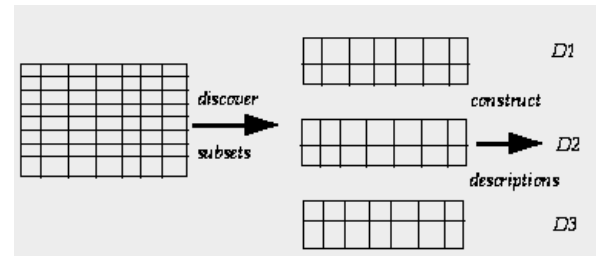

The following is an example of objects that describe the weather at a given time. The objects contain information on the outlook, humidity etc. Some objects are positive examples denote by P and others are negative i.e. N. Classification is in this case the construction of a tree structure, illustrated in the

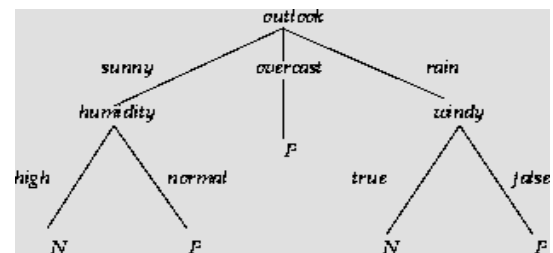

figure 2 which can be used to classify all the objects correctly.

**Fig 3. Decision tree structure**

#### 4.2.2 Rule Induction

A data mine system has to infer a model from the database that is it may define classes such that the database contains one or more attributes that denote the class of a tuple is the predicted attributes while the remaining attributes are the predicting attributes. Class can then be defined by condition on the attributes. When the classes are defined the system should be able to infer the rules that govern classification. Production rules have been widely used to represent knowledge in expert systems and they have the advantage of being easily interpreted by human experts because of their modularity i.e. a single rule can be understood in isolation and doesn't need reference to other rules. The structure of such rules is in the form of if-then rules.

#### 4.2.3 Neural Networks

Neural networks are an approach to computing that involves developing mathematical structures with the ability to learn. Neural networks can derive meaning from complicated or imprecise data and can be used to extract patterns and detect trends that are too complex to be noticed by either humans or other computer techniques. A trained neural network can be thought of as an "expert" in the category of information it has been given to analyze. Neural networks identify patterns or trends in data, they are good for prediction or forecasting. Neural networks use a set of processing elements (or nodes) analogous to neurons in the brain. These processing elements are interconnected in a network that can then identify patterns in data once it is exposed to the data, i.e. the network learns from experience just as people do. This distinguishes neural networks

Clustering and segmentation basically partition the database so that each partition or group is similar according to some criteria. Clustering/segmentation in databases are the processes of separating a data set into components that reflect a consistent pattern of behavior.

#### 4.2 Induction

Induction is the inference technique, which can be used to infer the generalized information from the database. Induction has been used in the following ways within data mining.

##### 4.2.1 Decision trees

Decision trees are simple knowledge representation and they classify examples to a finite number of classes, the nodes are labeled with attribute names, the edges are labeled with possible values for this attribute and the leaves labeled with different classes. Objects are classified by following a path down the tree,

from traditional computing programs that simply follow instructions in a fixed sequential order. The structure of a neural network is shown in the figure 4.

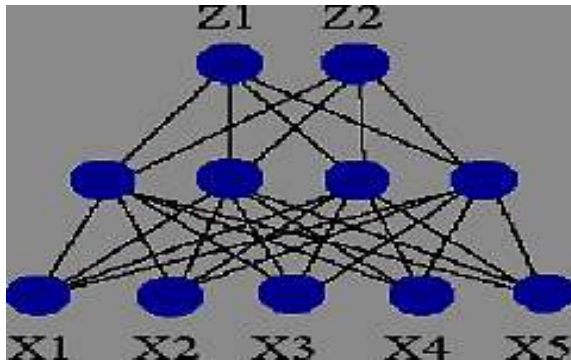

Fig 4. Structure of Neural Network

The bottom layer represents the Input layer, in this case with 5 input labels X1 through X5. The middle layer is called the hidden layer, with a variable number of nodes. The output layer in this case has two nodes, Z1 and Z2 representing output values we are trying to determine from the inputs. Neural networks suffered from long learning times, which become worse as the volume of data grows [2].

#### 4.2.4 Data Visualization

Data visualization makes it possible for the analyst to gain a deeper, more intuitive understanding of the data and can work well for data mining. Data mining allows the analyst to focus on certain patterns and trends and explore in-depth using visualization. The volume of data in a database can overwhelm the data visualization but in conjunction with data mining can help with exploration.

### 5. DATA MINING FUNCTIONS

Data mining methods may be classified by the function they perform or according to the class of application they can be used in. The data mining functions are as follows.

#### 5.1 Classification

The clustering techniques analyze a set of data and generate a set of grouping rules that can be used to classify future data. The mining tool automatically identifies the clusters, by studying the pattern in the training data. Once the clusters are generated, classification can be used to identify, to which particular cluster, input belongs. For example, one may classify diseases and provide the symptoms, which describe each class or subclass [5].

#### 5.2 Association

Given a collection of items and a set of records, each of which contain some number of items from the given collection, an association function is an operation against this set of records which return patterns that exist among the collection of items. These patterns can be expressed by rules such as "72% of all the records that contain items A, B and C also contain items D and E." The specific percentage of occurrences (in this case 72) is called the

confidence factor of the rule. Also, in this rule, A, B and C are said to be on an opposite side of the rule to D and E. Associations can involve any number of items on either side of the rule.

A typical application that can be built using an association function is *Market Basket Analysis*. Thus, by invoking an association function, the market basket analysis application can determine affinities such as "20% of the time that a specific brand toaster is sold, customers also buys a set of kitchen gloves and matching cover sets."

A supervised machine learning task involves constructing a mapping from input data (normally described by several features) to the appropriate outputs. In a classification learning task, each output is one or more classes to which the input belongs. The goal of classification learning is to develop a model that separates the data into the different classes, with the aim of classifying new examples in the future.

Given a new example, the ensemble passes it to each of its multiple base models, obtains their predictions, and then combines them in some appropriate manner (e.g., averaging or voting).

#### 5.3 Sequential/Temporal patterns

Sequential/temporal pattern functions analyze a collection of records over a period of time for example to identify trends. The identity of a customer who made a purchase is known, an analysis can be made of the collection of related records of the same structure. Sequential pattern mining functions can be used to detect the set of customers associated with some frequent buying patterns. For example a set of insurance claims can lead to the identification of frequently occurring sequences of medical procedures applied to patients which can help identify good medical practices as well as detect some medical insurance fraud.

#### 5.4 Clustering and Segmentation

Clustering and segmentation are the processes of creating a partition so that all the members of each set of the partition are similar according to some measure. A cluster is a set of objects grouped together because of their similarity or proximity. When learning is unsupervised then the system has to discover its own classes i.e. the system clusters the data in the database. Using the rules or functions can

Form the cluster.

### 6. DATA MINING ACTIVITIES AND USERS

Data mining activities are usually performed by three different classes of users: executives, end users and analysts.

- *Executives* spend much less time with computers than the other groups.
- *End users* are sales people, market researchers, scientists, engineers, physicians, etc
- *Analysts* may be financial analysts, statisticians, consultants, or database designers.

These users usually perform three types of data mining activity within a corporate environment: *episodic, strategic and continuous data mining*.

In *episodic mining* we look at data from one specific episode such as a specific direct marketing campaign. Analysts usually perform episodic mining. In *strategic mining* we look at larger

sets of corporate data with the intention of gaining an overall understanding of specific measures such as profitability. In *continuous mining* we try to understand how the world has changed within a given time period and try to gain an understanding of the factors that influence change [9].

## 7. DATA MINING APPLICATIONS

Data mining has many and varied fields of application, some of which are listed below.

- *Marketing*: Identify buying patterns from customers & Market basket analysis.
- *Banking*: Detect patterns of fraudulent credit card use & Identify 'loyal' customers.
- *Insurance and Health Care*: Claims analysis, Predict which customers will buy new policies & Identify fraudulent behavior.
- *Transportation*: Determine the distribution schedules & analyze loading patterns [7].

## 8. DATA MINING PROBLEMS

As data mining discovering the hidden knowledge from the available data, it also has some problems describing below:

- *Limited Information*: If some attributes essential to knowledge about the application domain are not present in the data it is impossible to discover significant knowledge about a given domain.
- *Noise and missing values*: Error in either the values of attributes or class information are known as noise. We have to omit the corresponding records of missing data or average over the missing values using Bayesian techniques.
- *Uncertainty*: Uncertainty refers to the severity of the error and the degree of noise in the data.
- *Size, updates, and irrelevant fields*: Databases are large and dynamic & their contents are changing as information is added, modified or removed. So, it is difficult to ensure that the rules are up-to-date and consistent with the most current information.

## 9. CONCLUSION

This paper comprehensively describes various terms and techniques of data mining. Also giving the concepts regarding functions, applications and processes of Data Mining. Data Mining or Knowledge Discovery in Databases (KDD) is the nontrivial extraction of implicit, previously unknown, and useful information from data.

## 10. REFERENCES

- [1] Data mining - concept and techniques Han & Kamber
- [2] DAVID OPITZ, RICHARD MACLIN (1999). "Popular Ensemble Methods: An Empirical Study". Journal of Artificial Intelligence Research 11 (1999) 169-198.
- [3] ROBI POLIKAR, "Ensemble based system in decision making", IEEE Circuits and system magazine, Third Quarter, 2006.
- [4] NIKUNJ C. OZA, (2004). "Ensemble Data Mining Methods".
- [5] U.N.PARMAR, S.J.AGRAVAT, A.K.RANPURA, "Multiple Classifier System using Bagging Method", Jan issue 2010, IJ-ETA-ETS, international journal, Sangli.
- [6] J. R. QUINLAN, (2006). "Bagging, Boosting, and C4.5".
- [7] "Building Data Mining application for CRM" - KURT THEARLING.
- [8] URESH PARMAR, NEHA PARTIWALA, NISHIDH CHAVDA, "QUEST (Quick Unbiased Efficient Statistical Tree): An efficient algorithm of Classification Tree in Data Mining", July issue 2010, IJ-ETA-ETS, international journal, Sangli.
- [9] Data mining - practical machine learning tools and techniques, Witten

# Optimized Rumor Routing Algorithm for Wireless Sensor Networks

Zalak Modi<sup>1</sup>, Sunil jardosh<sup>2</sup>, Sunil jardosh<sup>3</sup>

1.G.H.Patel college of Eng. and Tech., Anand

2.DA-IICT, Gandhinagar

3.DA-IICT, Gandhinagar

zalak\_modi2000@yahoo.com, Email:sunil\_jardosh@daiict.ac.in,Email:prabhat\_ranjan@daiict.ac.in

**Abstract:** *Wireless Sensor Network is data centric network that works on query reply mechanism with various types of queries. Rumor routing is of the data centric routing algorithm for Wireless Sensor Networks. Literature shows that Rumor routing algorithm is energy efficient than the Ant Colony Optimization, Gossip Routing, Deterministic Flooding and Directed Diffusion. Data centric WSN works has various types of queries that govern the traffic patterns of WSN. In our work we have exploited this key feature of Data centric WSN for improving the energy efficiency of Rumor routing algorithm. Based on information requirement, we have classified queries in two parts, instantaneous queries and continuous queries. Using this query classification we have optimized the Rumor routing for different types of traffic patterns. Our simulation result shows significant reduction in energy consumption after applying our optimization over Rumor Routing algorithm which we called Optimized Rumor Routing.*

## I. INTRODUCTION

In recent years many Network Layer protocols have been designed for routing in Wireless Sensor Networks (WSN). Karaki and Kamal in [9] gave the survey of routing protocols used in WSN. They have classified the routing protocols based on their node deployment strategy (deterministic or probabilistic), data reporting strategy (time driven, event driven, query driven or hybrid) and Energy consumption strategy without losing accuracy. Based on this survey Rumor Routing [1] can be classified as data centric kind of routing algorithm for WSN. Mainly Rumor routing algorithm is used when the geographical location of deployed nodes are unknown. For an example, randomly deployed environment monitoring network or habitat monitoring network uses Rumor routing as Network Layer routing protocol.

In WSN Data collection is divided into two parts query flooding and event flooding. Both the flooding mechanism creates energy overhead in WSN. Recent literature on WSN shows that many proposed schemes try to control query flooding and event flooding to reduce energy overhead of data collection. Rumor routing algorithm is a logical compromise between query flooding and event flooding. Ref. [4] has defined zonal rumor

routing which increases the query delivery rate by introducing zones in WSN. Ant colony algorithm [5] was used to know the behavior of the event agents or query agents, while in directional rumor routing [6] algorithm uses straight line approach instead for the random walk. Zonal rumor routing introduced by [4] shows that rumor routing is an energy efficient algorithm compared to gossip based routing, directed diffusion, Ant Colony Optimization and Deterministic Flooding. The randomized rumor routing algorithm increases the robustness of rumor routing algorithm. As shown above, literature in Rumor routing focuses on the query propagation model but they have not used the knowledge available in the query. In the paper we have used that available query knowledge to increase the efficiency of Rumor routing in data collection. To achieve this we have classified the query according to their need of information. As the traffic in network depends on the type of query generated by the network, use of available knowledge in query reduces the network traffic and gives longer network lifetime. Our proposed approach is complementary to all the suggestions proposed above and helps them further in improving the performance of network.

Rest of the paper is organized as follow. Section 2 covers working of our Query aware rumor routing protocol, section 3 covers algorithm for the different nodes and Section 4 covers our simulation results. We have concluded our paper in section 5 with discussion and future work.

## II. 2. QUERY AWARE RUMOR ROUTING

Rumor routing is a data centric routing algorithm. Such algorithms are used in networks where nodes are unaware of their geographical location. In Rumor routing, rumor is information about the event or a query for certain events, which is routed in the network. As nodes don't know the geographical location of destination or neighboring nodes, nodes transmit the information in the form of event or query agent. The node which generates the event is called the event node. Same way any node that wants to know about the event, will transmit the query agent and such a node is called the query node. In the network at the node where query agent and event agent meet each other or they both go through the path visited by each other they exchange the

information. By this they came to know about each other and thus the path is formed between event node and query node. Now the information will be passed through this path in both directions. Rumor routing is a logical compromise between event and query flooding. Following is list of terms we have use in our algorithm.

Table 1: Terms Used in Algorithm

<b>Event Agent</b>	An Event Agent is a packet that is responsible for spreading rumors about the events in the network. Each agent is associated with the time to live (TTL) that determines the number of hops that agent can traverse before it dies. An agent maintains an event list and a visited node history list.
<b>Query Agent</b>	A query is a request packet for receiving information on a particular event. Each query is associated with a time to live (TTL) that determines the number of hops the query can make. A query is considered undelivered when it does not reach its destination before the expiration of TTL. Like an event agent, a query agent also maintains a list of visited nodes or zones in a history list.
<b>Event List</b>	This list stores the event names and the distance to the events. Agents and nodes maintain their respective event lists.
<b>Neighbor List</b>	In case of Rumor Routing, neighbor list stores the node ids of the neighbors.
<b>History List</b>	In case of Rumor Routing, history list stores the node ids of the previously visited nodes. These lists maintain soft state information.
<b>Communication Range</b>	Communication range is the maximum distance that a node can send packet through wireless transmission. Therefore each node can send packet to other nodes that are within its communication range.
<b>Sensing Range</b>	This is the maximum range of each sensor node in which a sensor can detect the events. A sensor can detect multiple events occurring within its sensing range.
<b>Event path</b>	Along with spreading the rumor, the agent also constructs the event path, which is the shortest distance to the event the agent has discovered yet.

Thus the energy consumed by event node and query node for communication is  $N*V*I$ , where  $N$  is number of nodes over path

length and  $V$  is voltage needed for one node to transmit the data to the neighbor node on the path established by rumor routing and  $I$  is the drawn current.

a) *Optimized rumor routing algorithm:*

In the traditional rumor routing explained by [1], once the path is established between event node and query node, every query dispatched from query agent will go to event node for the information. In our algorithm we optimized the energy consumption of the network by using the knowledge available in query. We have classified the query in to two parts. This classification is based on the requirement of information for the particular event for which a query agent has been dispatched from a query node.

One type of the query needs the instantaneous information about an event (an over view of event) which is provided by the event agent when it meets the query agent while searching the path towards query. After that this query agent will come back to the query node. This kind of query agent does not need to go to the event node as its requirement of information is fulfilled. Total power consumed by this query is message transmission cost from query node to the meeting point of query agent and event agent. Here query need not have to go to event node so the total power consumption is lesser then the original rumor routing algorithm. Second type of agent needs the information about the event for the longer time span and asks for more information about the event. This kind of query agent will go to the event node because it needs more information about the event compared to instantaneous information oriented query agent. The query is classified before query node sends the query in the network. The result shows that the significant reduction in power consumption has achieved after applying proposed optimization technique in rumor routing algorithm on wireless sensor networks.

Let us take one simple exam suppose fire occurs at any node A, node B which is a query node needs information about the instantaneous temperature information at that node. Now for this information query agent of node B need not required to reach event node A. the information about the temperature will be available by the event agent itself. Now suppose the another query from the node B need the regular update on information about the temperature from the event node. In this case query agent requires going to the event node to make it aware of period event dispatch. This requires the same power as used in traditional Rumor routing Algorithm. In the following section we have shown the algorithms that runs our Query Nodes, Event Nodes and Intermediate Nodes.



### III. 3. ALGORITHM

In the above section gives the working principle of our optimized rumor routing algorithm. This work is complementary to the other suggested algorithms and helps in improving the performance of the rumor routing algorithm. In this section we have given the steps needed to perform at different nodes in the network.

#### A. Query Node:

Query node generates the query to get the information from network about the event. If path information about the event exists at query node then node takes next node to send query from that path, other wise they chose one of the neighboring node randomly and sends the query to that node. In the case if it receives the event information it store the path for the future use. The steps for the Query node are give below.

#### Steps for the Query Node

- 1 Set Communication Range
- 2 Set Query Frequency
- 3 Send  $k$  random Hello Packet
- 4 Wait for Neighbor Hello Packet for Predefine time
- 5 Set Query Type
- 6 Send Query Base on Query Type and Query Configuration
- 7 If Path present for event
- 8 Use neighboring node from path
- 9 Else
- 10 Select node randomly from neighbor list
- 11 Send Query with TTL
- 12 Repeat Step 8 base on Step 6
- 13 On Receive Event Agent
- 14 Get Path Information form Agent
- 15 Store information in list with purge time
- 16 On purge time Remove Entry from Query Node

#### B.

#### C. Source/Event Node:

Node that senses the environment and generative the data are called source nodes or event nodes. Event node sends the information toward the Query nodes in the event agents.

#### Steps for the Query Node

- 1 Set Communication Range
- 2 Set Event Frequency
- 3 Send  $k$  random Hello Packet
- 4 Wait for Neighbor Hello Packet for Predefine time
- 5 Set Event Type
- 6 Send Query Base on Query Type and Query Configuration
- 7 If Path present
- 8 Use next hop node from path
- 9 Else
- 10 Select Random Neighbor Node
- 11 Send Query with TTL
- 12 Repeat Step 11 base on Step 6
- 13 On Receive Event Agent
- 14 Get Path Information form Agent
- 15 Use this information for future with purge time
- 16 On purge time Remove Entry from Query Node

#### D. Intermediate Node:

Intermediate node receives the query agents and event agents and forwards them according to algorithm. In the case that node has query agent and receives the event agent it uses that information for query agent and forward the event on query path. On receiving query agent when it has related event agent it follows the same processer. In addition based on the query type it either forwards the query agent towards the event node or drops query agent and do not forward it.

#### Steps for the Intermediate Nodes

- 1 Receive the query and event agent
- 2 If only query or only event agent
- 3 Store the query and event agent
- 4 If TTL is not zero
- 5 Forward received query or event agent
- 6 Else
- 7 Drop query or event agent
- 8 Else
- 9 Forward query or event, base on received event or query information respectively
- 10 If long term query
- 11 Forward query to event node
- 12 Else
- 13 Drop query

Intelligent behavior of intermediate node based on query information helps the network to reduce the forwarded packets in the network.

#### IV. 4. RESULTS

In our simulation we have compared our query based Rumor routing algorithm with traditional Rumor routing algorithm. To compare both the protocols we have used the scalability of the network, transmission range of nodes and communication range as parameters. Algorithms are evaluated for the energy consumption requirement for different sets of parameters. In addition we have tested both the algorithms with different topological structures. For this purpose we took two topological structures one is grid and other is random node distribution. In our simulation for fix deployment region we have increased the node density per unit area, transmission range and query/event frequency and compared the standard rumor routing with our optimized rumor routing on the basis of energy consumption. In random node deployment we have assumed that for fixed power consumption per node, we are getting the connectivity which includes at least one node in its communication range.

Result in figure 1 shows the energy consumption in grid structure. Here we have increased the network size by increasing node density per unit area and analyzed the energy consumption of the network. Result shows that with optimization plotted in red line have lower energy consumption compared to without optimization shown in blue line. For random node deployment, the result is shown in figure 2.

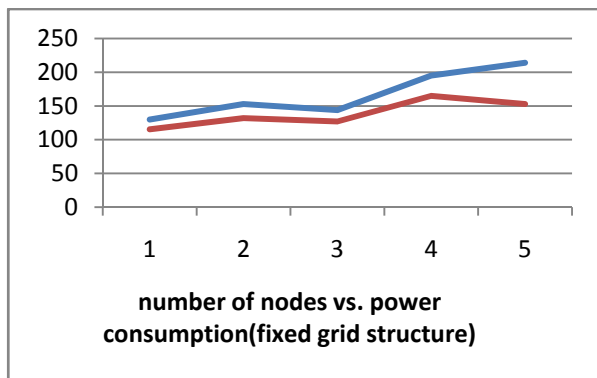

Figure 1: number of nodes vs. power consumption (fixed grid structure)

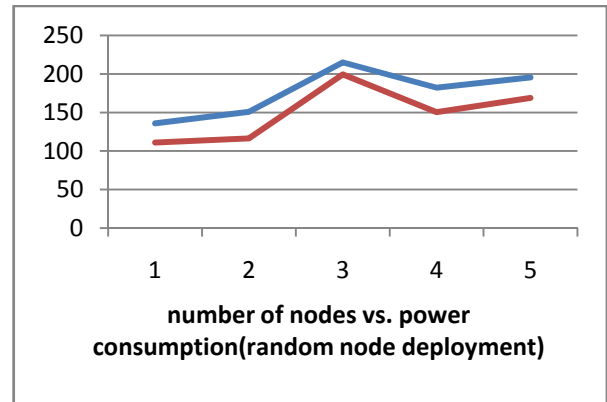

Figure 2: number of nodes vs. power consumption (random node deployment)

Here also red line shows the energy consumption due to optimized rumor routing while blue line shows the energy consumption due to traditional rumor routing. Result shows the significant reduction in energy consumption using optimized rumor routing algorithm.

The communication range is one of the parameter on which the network traffic depends on. For this query frequency is another parameter that we have used for comparing the both routing algorithms. The effect of communication on energy consumption has been evaluated both on grid as well as random structure. The figure 3 below shows the energy consumption for fixed grid structure for various communications ranges 6, 7, 8, 9, 10 and 11.

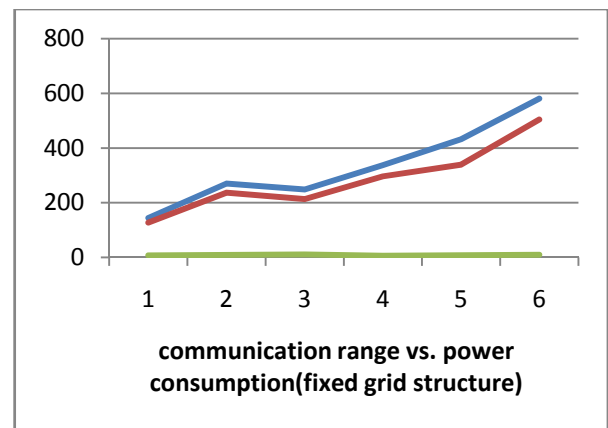

Figure 3: Communication range vs. power consumption for fixed grid structure.

For same ranges of communication we have changed the topological structure by random deployment. In both the figures red line shows the optimised rumor routing algorithm and blue line shows the traditional rumor routing algorithm.

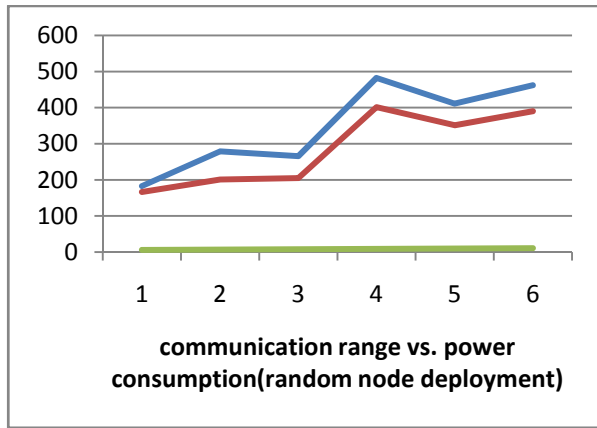

Figure 4: Communication range vs. power consumption for random node structure.

The significant improvement in energy consumption is clearly visible in all four graphs. The assumption over here is made that we can not take query node itself as event node. If we are taking a query node as event node also the results may differ.

#### Future work

We can change the query frequency (query agent per second) for single event as well as for multiple events. Also we can apply the above idea and algorithm for random and fixed grid structure.

#### V. CONCLUSION

In this paper we have proposed the query based Rumor routing algorithm which uses the information available in the query agent for the optimize routing. We have classified the query in two part instantaneous and long term queries. Based on this classification intermediate node makes their decision about the query forwarding. We have compared our algorithm with the tradition Rumor routing algorithm; simulation shows that our algorithm consumes the less energy and more energy efficient than the traditional algorithm.

#### VI. REFERENCES

- [1] Braginsky, D. and Estrin, D. 2002. Rumor routing algorithm for sensor networks. In *Proceedings of the 1st ACM international Workshop on Wireless Sensor Networks and Applications* (Atlanta, Georgia, USA, September 28 - 28, 2002). WSNA '02. ACM, New York, NY, 22-31. DOI=<http://doi.acm.org/10.1145/570738.570742>.
- [2] A. Coloni, M. Dorigo et V. Maniezzo, *Distributed Optimization by Ant Colonies, actes de la première conférence européenne sur la vie artificielle*, Paris, France, Elsevier Publishing, 134-142, 1991.
- [3] Okdem, S. and Karaboga, D. 2006. Routing in Wireless Sensor Networks Using Ant Colony Optimization. In *Proceedings of the First NASA/ESA Conference on Adaptive Hardware and Systems* (June 15 - 18, 2006). AHS. IEEE Computer Society, Washington, DC, 401-404. DOI=<http://dx.doi.org/10.1109/AHS.2006.63>
- [4] Li, X., Moaveninejad, K., and Frieder, O. 2003. Regional Gossip Routing for Wireless Ad Hoc Networks. In *Proceedings of the 28th Annual IEEE international Conference on Local Computer Networks* (October 20 - 24, 2003). LCN. IEEE Computer Society, Washington, DC, 274.
- [5] Lin, M., Marzullo, K., and Masini, S. 1999 *Gossip Versus Deterministic Flooding: Low Message Overhead and High Reliability for Broadcasting on Small Networks*. Technical Report. UMI Order Number: CS1999-0637., University of California at San Diego.
- [6] Intanagonwiwat, C., Govindan, R., and Estrin, D. 2000. Directed diffusion: a scalable and robust communication paradigm for sensor networks. In *Proceedings of the 6th Annual international Conference on Mobile Computing and Networking MobiCom '00*. ACM, New York, NY, 56-67. DOI=<http://doi.acm.org/10.1145/345910.345920>
- [7] Banka, T., Tandon, G., and Jayasumana, A. P. 2005. Zonal Rumor Routing for Wireless Sensor Networks. In *Proceedings of the international Conference on information Technology: Coding and Computing (Itcc'05) - Volume II - Volume 02* (April 04 - 06, 2005). ITCC. IEEE Computer Society, Washington, DC, 562-567. DOI=<http://dx.doi.org/10.1109/ITCC.2005.305>
- [8] Shokrzadeh, H., Mashaieki, M., Nayebi, A., Improving Directional Rumor Routing in Wireless Sensor Networks, *Conference on Innovations in Information Technology, 2007. IIT '07. 4th International* (Nov 18-20, 2007), 108-112.
- [9] Al-Karaki, J.N. Kamal, A.E., Routing techniques in wireless sensor networks: a survey, In *proceeding of IEEE Wireless Communications*, Vol 11, Issue 6, 6-28. Dec 2004.

# Fabrication of Macropore Arrays in Silicon

Mr Amit R Sharma

Asst Professor, E.C. Department, Ghandhinagar Institute of Technology, Ghandhinagar.  
amit.sharma@git.org.in

**Abstract:-The fabrication of macropore arrays in silicon by photo electrochemical etching technique in hydrofluoric acid (HF) solution is presented in this article. The formation of pore arrays with high aspect ratios by electrochemical etching of n-type silicon in hydrofluoric acid is a well established technique. The macropore morphology depends sensitively on the anodization conditions such as current density, etching time, HF concentration, light and bias voltage as well as on substrate properties such as orientation. When macroporous silicon is metallized with Nickel plating and filled with scintillating powder it acts as a waveguide for the visible light, and can improve X-ray detectors. By improving the quality of the macropores viz depth, width, flat wall, and flat bottom, one would improve the image quality of an X-ray detector.**

## 1. Introduction

This article is the result of a project in applied sensor technology at Mid Sweden University. The project is focused on the fabrication of macropores in silicon.

Fabrication of macropores by electrochemical etching in optional patterns pre-determined by photo-lithography has been known since 1990. The working of X-ray imaging detectors is based on this photo electrochemical growth process. V.Lehmann and U. Gruning<sup>[1]</sup> etched 2µm deep pores by using a 4Ω n-type substrate. According to them the smallest pore diameter realized so far in a regular macropore array is about .3 µm. Xavier Badel<sup>[2]</sup> achieved pore depth of 380µm, pore spacing of 30µm and wall of 3µm.

Macropores are useful in X-ray imaging detector. Different parameters like temp, time, voltage, current and conc. of HF solution can vary the quality of the macropores. The macropores were plated with Ni and filled with scintillating powder Terbium doped gadolinium oxysulphide (Gd<sub>2</sub>O<sub>2</sub>S:Tb). Then this device was tested for X-Ray sensitivity using dental X-ray source.

## 2. Electrochemical Etching of silicon

Electrochemical etching involves both acid and positive charged holes to dissolve the material. Silicone can be etched with hydrofluoric acid (HF), the etching rate can be controlled by adjusting the number of holes reaching the surface. One of several reactions that take place during the etching is:

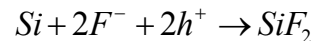

and



This uses two holes to dissolve one silicone atom. A similar reaction also takes place using four holes to dissolve one silicon atom. Other reactions are possible as there are many ions in the solution: (HF)<sup>2-</sup>, F<sup>-</sup>, OH<sup>-</sup>, F<sup>-</sup>, H<sub>3</sub>O<sup>+</sup>. Because the holes are used, new holes have to be supplied by external means. In n-type silicone holes are created by exposing the back of the wafer with light, a bias voltage move the holes to the surface of the wafer.

By measuring the current density and calculating the number of holes used during the etching, it is possible to decide which reaction is dominant. If the average number of holes used is close to two, this will result in porous etching of the silicon. Whilst if the number of holes is close to four, electro polished etching will occur. Between porous and electro polished etching there is an transition region where the current density is defined as J<sub>ps</sub>.

During etching of macropores the applied voltage will produce a "Space Charge Region"<sup>[3]</sup> that focuses the holes on to the tip of the pore, hence only at the pore tip etching will occur.

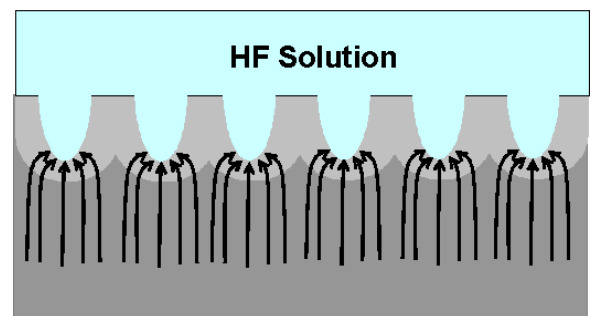

Figure 1

The current density at the pore's tip is equal to J<sub>ps</sub> and the number of holes used to dissolve a silicon atom is approximately 2.6 during macropore formation. An increase in the bias voltage will reduce the space charge region, this will increase the pore diameter and reduce the wall thickness.

### 3. Experimental process

N-type, <100> orientation, 1000Ωcm resistance silicon wafers were taken for the experiments. Pyramids were etched with KOH form a good start for macropores

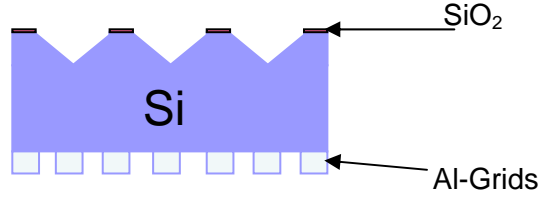

Figure 2 Cross-section of a wafer

The backside of the wafer is covered with Aluminium that supplies a good electrical contact for the bias voltage. In this case a halogen lamp was used on the backside providing the holes. So a grid of aluminium is made so light can get through and create holes.

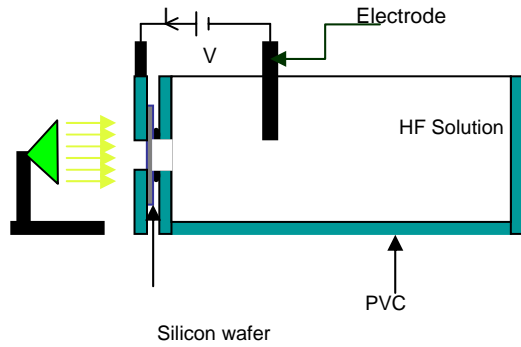

Figure 3 Experimental setup

The container is made of PVC which is resistant to HF. A platinum electrode are mounted which is used for bias voltage. The light source is located at the back side of the sample.

### 4. Equations

The HF concentration  $c$  in percentage of weight (wt% ), was calculated as follows:

$$c = \frac{1}{2} * \frac{V_{HF50\%} * \rho_{HF50\%}}{V_{H_2O} * \rho_{H_2O} + V_{ethanol} * \rho_{ethanol} + V_{HF50\%} * \rho_{HF50\%}} \quad (\text{Eq. 1})$$

If the concentration of HF used in the experiment was 4.2 wt% then a total of 4dl solution was prepared for the experiment which includes 300ml of H<sub>2</sub>O, 100ml of ethanol and 30 ml of HF<sub>50%</sub> solution.

The critical current density in <100> N-type Si-wafer is calculated by:

$$J_{ps} = Cc^{3/2} * \exp(-E_a / kT) \quad (\text{Eq. 2})$$

$C = 3300A/cm^2$ ,  $c = \text{HF conc.}$ ,  $E_a = 0.345\text{eV}$  and  $k = \text{Boltzmann's constant}$ .

The pore diameter with square pores is calculated by:

$$d = p \sqrt{(J / J_{ps})} \quad (\text{Eq. 3})$$

$p = \text{spacing of the pores}$ ,  $J = \text{etching current}$ .

If the HF concentration is changed then the  $J_{ps}$  also changes, the new  $J_{ps}$  is calculated by:

$$J_2 = J_1 \times \left( \frac{c_2}{c_1} \right)^{3/2} \quad (\text{Eq. 4})$$

### 5. Metallization

The electroless Ni plating technique was used to metallize the macro porous silicon. The composition of the electroless Ni plating bath was essentially the same as that reported by S Dhar and S Chakrabarti. [4]

The temp of the bath is kept at room temp in a ultra sonic bath, and samples were kept in this solution for 10 min to 60 min.

When metallized the walls of pores acts as reflecting surface for the visible light, hence the porous silicon acts as a wave guide for the light concentrating it on the CCD.

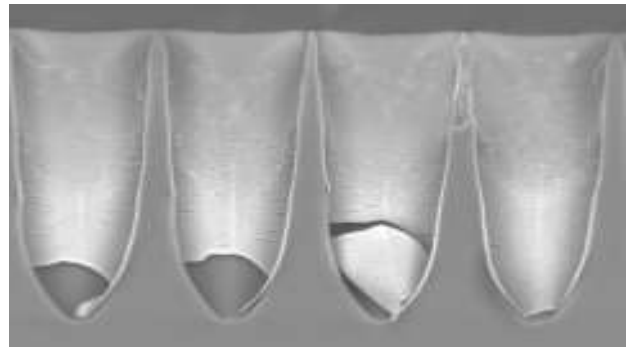

Figure 4 SEM picture of plated pores.

## 6. Macropore arrays as X-ray detector.

In the final step of our project we filled a macropore array with scintillating powder in order to check the performance of a macropore based sensor.<sup>[2]</sup> Due to limited time it was not possible to explore this area of the project fully. Scintillating powder is used to convert X-rays into visible light that can be collected by a CCD sensor.

Digital X-ray detectors based on macropore arrays with scintillating powder serves in two ways to reduce the X ray dose, at first they increase the resolution and secondly they reduce the duration of exposure, Since some Scintillating powder require less exposure than ordinary film imaging.

The problem aroused in properly filling the macropore arrays with scintillating powder. Ultra sonic vibrators can be used as a apparatus for filling macro pores but some modification of existing apparatus is required. There is also a need for properly measuring the different parameters that will categorize the performance of device.

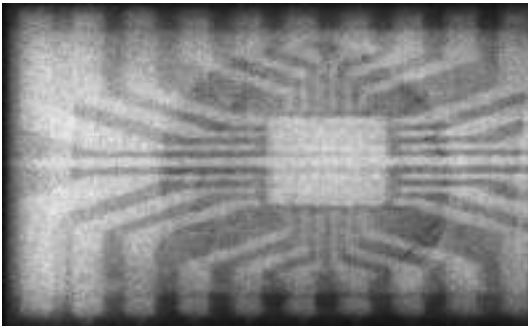
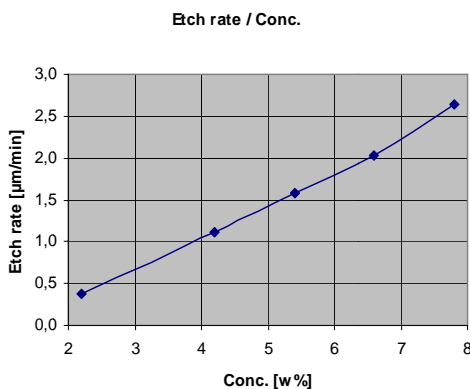

Figure 5 X-ray of an IC. The darker circle is the area with macropores that improve the contrast in the X-ray image.

## 7. Results

During electrochemical etching the number of silicon atoms dissolved is controlled by the current density. Our experimental result shows that the dept of the macropores was independent of the current applied during the etching. This is because the pore diameter is increasing when the current density is increasing according to Eq. 3. The area of the pore is equal to  $d^2$  if you have square pores. And the dept of the pores are independent of the current density.



By increasing the concentration of the HF solution the etch rate can be increased. Our experiments showed good linearity between HF concentration and reached dept.

Figure 6

Higher concentrations needs more holes and if you cant supply enough holes the wall quality may degrade. Figure 7 and 8 shows SEM images of the tip of two macropore's. In figure 8 higher concentration have been used and the current used was recalculated according to Eq. 4 to match the current in figure 7

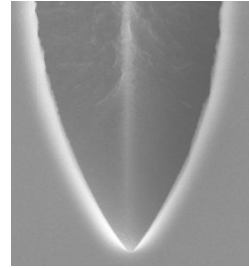

Figure 7

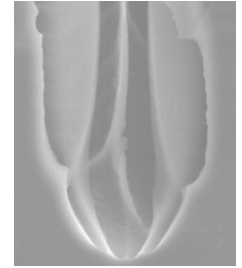

Figure 8

Figure 9 and 10 shows SEM images of pores etched with different current density.

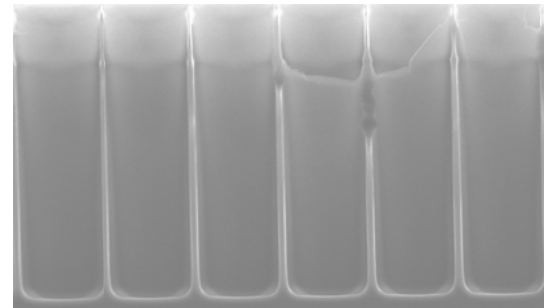

Figure 9 Current = 56mA, HF Conc = 4.2%wt, Time = 120 min

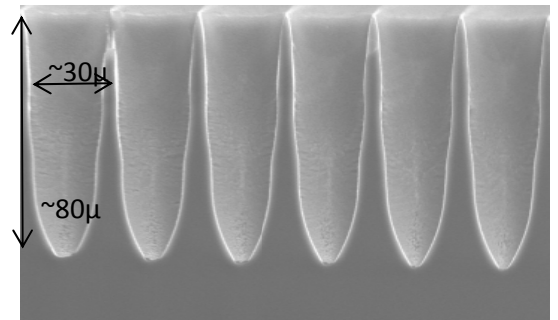

Figure 10 Current = 48mA, HF Conc = 4.2%wt, Time = 120 min

High current density led to more electro polishing which explains the flat pore bottoms and the thinner walls.

## 8. Conclusion

I successfully fabricated macropores over 310  $\mu\text{m}$  deep.

From the above experiment it can be inferred that current does not effect the etch rate. The etch rate is dependent on HF concentration. And we get deeper pores when the setup is kept for longer period of time.

The polishing of the pores depends on the current. At high current we got thin walls and flat bottoms as can be seen in figure 9.

Little time was used fore metallization and the plating process was not optimized for plating of macropores. There for the plating result was not as good as expected.

We were unable to completely fill the pores with scintillator powder. Due to limited time no effective method for filling pores were found. So the X-ray detector was not working satisfying.

## Acknowledgments

I am thankful to Göran Thungström myr teacher who gave me technical support and Henrik Andersson my supervisor for specially helping in clean room lab. I am also thankful to Mid-Sweden University for providing me with good computer and lab facilities.

## References

- [1] The limits of macropore arrays formation by V. Lehmann and U. Gruning
- [2] Development of macropore arrays in silicon and related technologies for X-ray imaging applications by Xavier Badel, KTH , Royal institute of Technology
- [3] Porous silicon – A new material for mems by V. Lehmann
- [4] Electroless Ni plating on n- and p-type porous Si for ohmic and rectifying contacts by s Dhar and S Chakrabarti.

# ANALYSIS OF MAGNETIC FLUID BASED SQUEEZE FILM BETWEEN TWO CURVED CIRCULAR PLATES

Nikhilkumar D. Abhangi<sup>1</sup>, G.M. Deheri<sup>2</sup>, Chandaniben D. Changela<sup>3</sup>

<sup>1</sup> Gandhinagar Institute of Technology, Gandhinagar, Gujarat, India,

<sup>2</sup> Department of Mathematics, Sardar Patel University, V.V.Nagar, Gujarat, India,

<sup>3</sup> Gandhinagar Institute of Technology, Gandhinagar, Gujarat, India, changela.

nikhil.abhangi@gmail.com, gmdeheri@gmail.com, [chandni@gmail.com](mailto:chandni@gmail.com)

**ABSTRACT:** Efforts have been directed to study and analyze the behavior of a magnetic-fluid-based squeeze film between curved rough circular plates when the curved upper plate (with surface determined by an hyperbolic expression) approaches the stationary curved lower plate (with surface governed by a secant function). The lubricant used is a magnetic fluid in the presence of an external magnetic field oblique to the radial axis. The associated Reynolds equation is then solved with appropriate boundary conditions to obtain the expressions for pressure and load carrying capacity. The numerically computed results are presented graphically. It is found that load carrying capacity increases with increasing magnetization. Further, it is seen clearly from the figures that the performance of the bearing system gets significantly enhanced due to the magnetization. It is observed that the load carrying capacity increases with respect to the curvature of the upper plate while a symmetric distribution takes place with regard to the lower plate's curvature parameter.. The analysis as well as the figures suggests that the bearing performance might be improved considerably by a proper choice of both curvature parameters in the presence of a magnetic fluid as lubricant. In addition this article also provides some measures to extend the life period of the bearing system.

## 1. INTRODUCTION

Murti [1] discussed the squeeze film behavior between a curved upper plate and a flat lower plate and established that the load carrying capacity rose sharply with curvature in the case of concave pads. Gupta and Vora [2] studied the corresponding problem for annular plates. In the above studies the lower plate was considered to flat one. Ajwaliya [3] analyze the problem of squeeze film behavior by modifying the approach of Gupta and Vora [2] taking the lower plate also curved. According to his investigations such situation could be found useful in design of machine elements like clutch plates and collar bearings. In all the above investigations conventional lubricants were used. Verma [4] and Bhat and Deheri [5] analyzed the squeeze film behavior between porous plates. It was concluded that the application of magnetic fluid lubricant enhanced the performance of squeeze film. However they assumed that the plates were flat. But in actual practice, the flatness of the plate does not endure owing to

elastic, thermal and uneven wear effects. With this end in view, Patel and Deheri [6] analyzed the behavior of the magnetic fluid based squeeze film between curved plates determined by secant functions. They found that the magnetic fluid lubricant improved the performance of the bearing.

Here an attempt has been made to deal with the performance of a magnetic fluid based squeeze film between a curved upper plate lying along a surface determined by hyperbolic function and a curved lower plate along the surface governed by secant function.

## 2. ANALYSIS

The configuration of the bearing is as shown in Figure 1. It is assumed that the upper plate lying along the surface given by

$$Z_u = h_0 \left[ \frac{1}{1 + Br} \right]; 0 \leq r \leq a \quad (1)$$

Approaching the lower plate lying along the surface

$$Z_l = h_0 \left[ \sec(-Cr^2) - 1 \right]; 0 \leq r \leq a \quad (2)$$

with the normal velocity  $\dot{h}_0 = \frac{dh_0}{dt}$ , where  $h_0$  is the central distance between the plates, and  $B$  and  $C$  are the curvature parameters of the corresponding plates. The central film thickness  $h(r)$  then is defined by

$$h(r) = h_0 \left[ \frac{1}{1 + Br} - \exp(-Cr^2) + 1 \right]. \quad (3)$$

Assuming axially symmetric flow of the magnetic fluid between the plates under an oblique magnetic field

$$\vec{H} = (H(r) \cos \varphi(r, z), 0, H(r) \sin \varphi(r, z)),$$



whose magnitude  $H$  vanishes at  $r = a$ , the modified Reynolds equation governing the film pressure  $p$  is [4, 5, 6] obtained as

$$\frac{1}{r} \frac{d}{dr} \left[ rh^3 \frac{d}{dr} \left( p - \frac{1}{2} \mu_0 \bar{\mu} H^2 \right) \right] = 12\mu \dot{h}_0 \quad (4)$$

where  $\mu_0$  is the free space permeability,  $\bar{\mu}$  is the magnetic susceptibility and  $\mu$  is the fluid viscosity. Taking, for instance

$$H^2 = a(a - r) \quad (5)$$

and remembering that the magnetic field arises out of a potential, it can be shown that  $\varphi$  the inclination angle satisfies the equation

$$\cot \varphi \frac{\partial \varphi}{\partial r} + \frac{\partial \varphi}{\partial Z} = \frac{1}{2(a - r)} \quad (6)$$

whose solutions are

$$C_1^2 \operatorname{cosec}^2 \varphi = a - r \quad \text{and} \quad Z = -2C_1 \sqrt{(a - C_1^2 - r)}$$

$C_1$  being a constant of integration.

Introducing the dimensionless quantities

$$\bar{h} = \frac{h}{h_0}, \quad R = \frac{r}{a}, \quad \mathbf{B} = Ba, \quad \mathbf{C} = Ca^2, \quad \mu^* = -\frac{\mu_0 \bar{\mu} h_0^3}{\mu \dot{h}_0} \quad (7)$$

and solving the Reynolds equation (4) using Equations (3) and (5) in view of the boundary conditions

$$P(1) = 0, \quad \frac{dP}{dR} = -\frac{\mu^*}{2} \quad \text{when} \quad R = 0 \quad (8)$$

(which physically mean that the pressure vanishes on the boundary of the bearing and that there is a radial flow from the axis due to magnetization), the dimensionless pressure and load carrying capacity obtained respectively form

$$P = -\frac{h_0^3 p}{\mu a^2 \dot{h}_0} = \frac{\mu^*}{2} (1 - R) + 6 \int_0^R \frac{R}{h^3} dR \quad (9) \quad \text{and}$$

$$\bar{W} = -\frac{Wh_0^3}{2\pi\mu a^4 \dot{h}_0} = \frac{\mu^*}{12} + 3 \int_0^1 \frac{R^3}{h^3} dR \quad (10)$$

### 3. RESULTS AND DISCUSSIONS

Expressions for dimensionless pressure  $P$  and load carrying capacity  $\bar{W}$  are presented in equation (9) and (10) respectively. From these two expressions it is clearly seen that the pressure increases by

$$\frac{\mu^*}{2} (1 - R)$$

while the increase in load carrying capacity is

$$\frac{\mu^*}{12}$$

as compared to the case of conventional lubricant.

Figures 2-3 present the variation of load carrying capacity with respect to the magnetization parameter for various values of the upper plate's curvature parameter and lower plate's curvature parameter respectively. It is clearly seen that the load carrying capacity increases significantly with increasing values of magnetization parameter. In Figures 3-4 once can visualize the effect of the curvature parameters on the load carrying capacity. The upper plate's curvature parameter increases the load carrying capacity while the lower plate's curvature parameter decreases the load carrying capacity. Further, the negative curvature of the lower plate tends to increase the load carrying capacity. Besides, the effect of  $\mu^*$  is negligible up to the value 0.01. Further the symmetric distribution is with respect to lower plate curvature parameter (Figure 4).

### 4. CONCLUSION

This article reveals that the performance of the bearing system can be improved considerably by choosing the magnetization parameter and curvature parameters of both the plates suitably.

## 5.REFERENCES

- [1] Murti, P.R.K., Squeeze films in curved circular plates, *J.Lubr.Technology*.97 (4), p. 650, 1975.
- [2] Gupta, J.L. and Vora, K.H., Analysis of squeeze film between curved annular plates, *J. Lubr.Technology*. 102, p. 48, 1980.
- [3] Ajwaliya, M.B., Behavior of squeeze films between two curved plates, Ph.D. Thesis , S.P.University, V.V.Nagar, 1984.
- [4] Verma, P.D.S., Magnetic fluid based squeeze film, *Int. J.Engng. Sci.* 24(3), p. 395, 1986.
- [5] Bhat, M.V. and Deheri, G.M., Squeeze film behavior in porous annular discs lubricated with magnetic fluid, *Wear*, 151, p. 123, 1991.
- [6] Patel, R.M. and Deheri, G.M., Magnetic fluid based squeeze film between two curved plates lying along the surfaces determined by secant functions, *Indian Journal of Engineering & Material Sci.*,Vol. 9, February, p. 45-48,2002.

Figure: 1 Configuration of the bearing system.

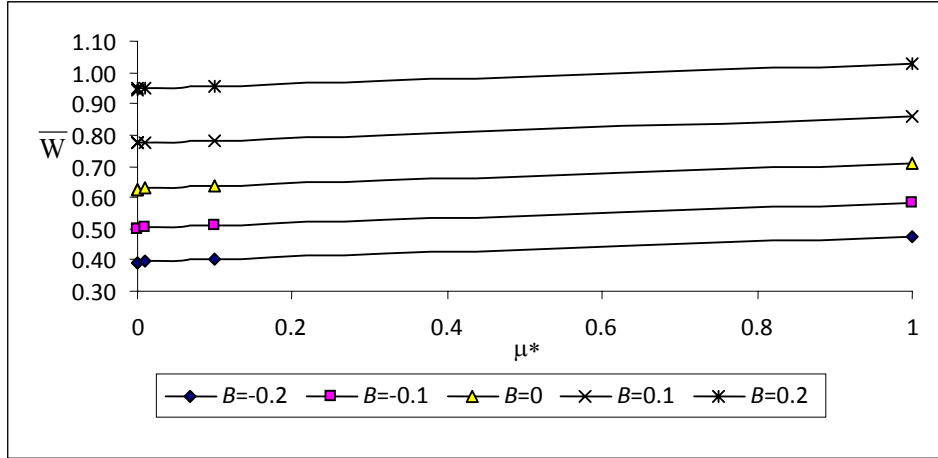

Figure: 2 Load carrying capacity with respect to  $\mu^*$  and  $B$

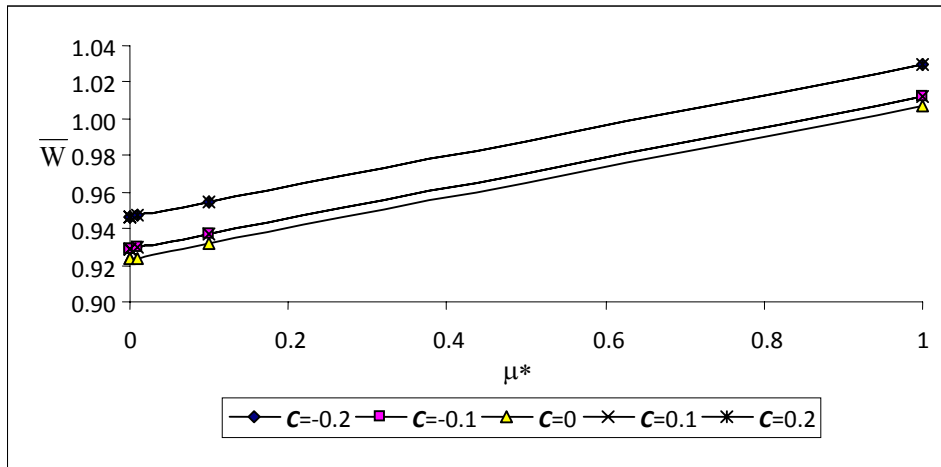

Figure: 3 Load carrying capacity with respect to  $\mu^*$  and  $C$

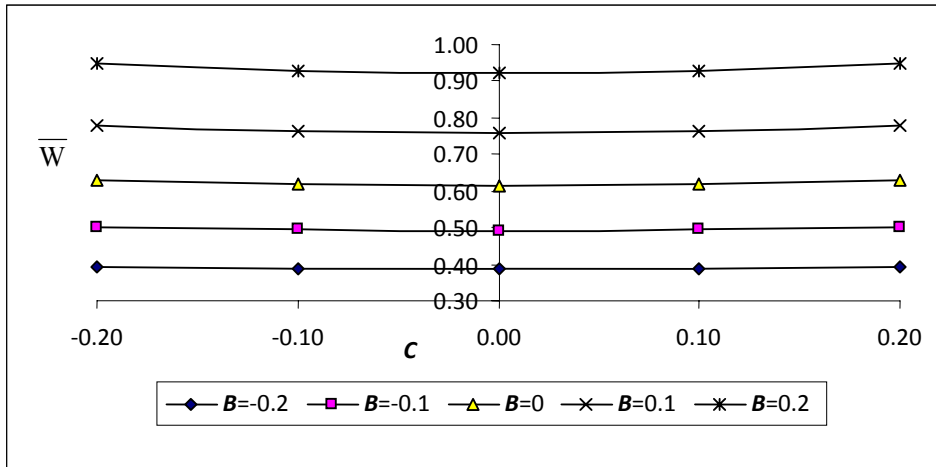

Figure: 4 Load carrying capacity with respect to  $C$  and  $B$

# APPLICATION OF SOLAR POWERED SEED SPRAYER IN AGRICULTURE – AN OVERVIEW

Milan J. Pandya <sup>1\*</sup>, Shaival R. Parikh <sup>2</sup>

<sup>1</sup> Lecturer, Mechanical Engineering Department, Gandhinagar Institute of Technology.

<sup>2</sup> Lecturer, Mechanical Engineering Department, Gandhinagar Institute of Technology.

\*Corresponding author (E-mail: milan.pandya@git.org.in)

## ABSTRACT

**This review paper deals with the design and working of “Solar Powered Seed Sprayer”. The solar seed sprayer is mainly use for agricultural purpose. It works under non-conventional energy which is the ultimate source for all living beings. The solar energy is converted into electrical with the help of solar cells. The converted electrical energy is completely stored in the battery and utilized to run a D.C. motor. Different kind of seeds can be sowed using this sprayer unit which also includes spraying solid substances and powder particles. It can be operated by a single person and is capable of covering an area of 6 hectares land in a single day.**

Key words: Solar seed sprayers, solar cell, lead acid battery, D.C. motor and hopper.

## INTRODUCTION

It is often said that food, clothing and shelter are the three basic needs of man kind. All the above three are based on agriculture. Agriculture is known to our people for thousands of years. But still our farmers in the villages are using only old-age technology. The population in our country has increased at least 3 times since our independence. The agricultural land has diminished in size and these lands have been diverted for industrial and domestic purposes.

For improving the productivity of our agricultural lands, it is stressed that they might employ high technology in every activity. Hence it will be in the fitness of things to design a device which can be operated annually. Therefore the idea of solar

powered seed sprayer becomes very helpful. Agriculture starts with sowing of seeds and fertilizers

and this particular activity have to carry out several times.

Hence if manually operated sprayer is designed it will prove to be a small but very effective step for achieving a high potential in growth.

### • *Solar Energy – A Boon to Mankind.*

Solar radiation is among the promising new source of energy. India receives annually over 60 x 1000 MWH of solar radiations with a span of 3000 – 3200 hrs. in Rajasthan, Gujarat, West of Madhya Pradesh and North of Maharashtra. Also around 2600 – 2800 hrs in the rest of the country excepting Kerala, Assam and Kashmir. Energy from the sun can be utilized in multi-various ways. It can be tapped directly from solar radiation in the form of thermal, thermodynamic and photo voltaic energy and indirectly through other related sources like wind, hydro power and ocean energy available on the planet Earth. The contribution of these sources in the total consumption of energy in the world is about 15 % only.

Traditionally, the utilization of solar energy has been confined to drying of agricultural products such as grains, maize, paddy, ginger, cashew, pepper, tobacco, fish and food drying. Its commercial application has been limited to production of common salt and other marine chemicals like potash, cromide and magnesium salts.

### Applications of Solar Technology.

- Solar water heating
- Space heating
- Space cooling
- Solar energy – thermal electric conversion
- Solar energy – photo voltaic electric conversion
- Solar distillation
- Solar pumping
- Agriculture and industrial process heating
- Solar furnace
- Solar cooking
- Solar production of hydrogen
- Solar green houses and the list goes on.

### DIRECT UTILIZATION OF SOLAR ENERGY

The most useful way of harnessing solar energy is by directly converting it into electricity by means of solar photo – voltaic cells. Sunshine is incident on Solar cells. In this system of energy conversion, direct conversion of solar radiations into electricity is carried out.

In recent year’s photo – voltaic power generation has been receiving considerable attention as one of the more promising energy alternatives. The reason for this rising interest lies in PV’s direct conversion of sunlight to electricity. The non polluting nature of the PV has increased its use considerably. Hence forth the low cost of conventional energy sunlight has obviated the development of a broad – based PV technology. At the present time, the PV generation can be justified only for special situations mostly for remote sites where utility lines on other conventional means of furnishing energy may be comparatively expensive and is one of the most attractive non-conventional energy sources of proven reliability from the micro to the mega watt level.

Like other energy system, this particular system also has some disadvantages.

1. Distributed nature of solar energy.
2. Absence of energy storage.
3. Relatively high capital cost.

### DESIGN OF SOLAR POWERED SEED SPRAYER

The design of the seed sprayer operated by the solar energy is very simple and also requires less operating cost. The following are the main components of the seed sprayer device.

1. Solar panel
2. Panel stand
3. Connecting wire

4. D.C. motor
5. Blower
6. Battery
7. Hose
8. Seeds
9. Hooper
10. Adjustable screw
11. Seed splitter

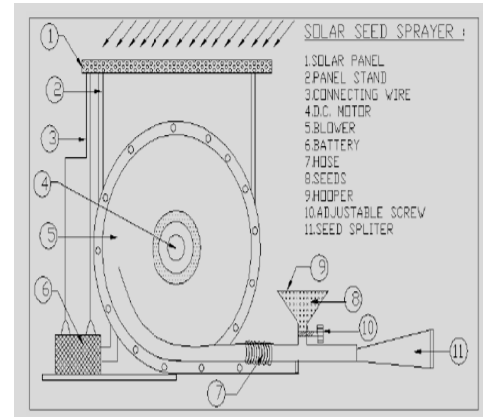
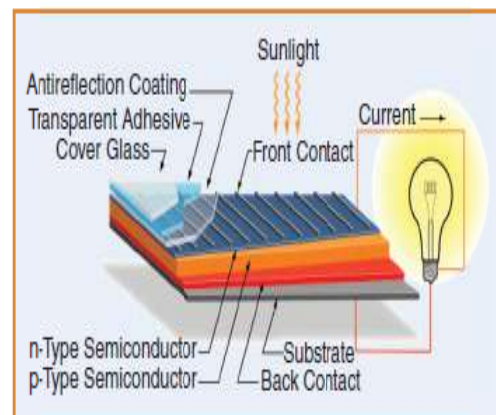

**Fig. 1.0 Design of solar powered seed sprayer**

The functions of the different components are as follows:-

#### 1. Solar panel.

The photo voltaic effect can be observed in nature in a variety of materials that have shown the best performance in sunlight. When the photons from the sun are absorbed in a semi conductor, that create free electrons with higher energies than the created, there must be an electric field to induce these higher energy electrons to flow out of the semi – conductor to do the useful work. A junction of materials which have different electrical properties provides the electric field in most solar cells.



**Fig. 2.0 Basic components of a photo voltaic cell**

## 2. Panel stand

It is used for providing the platform to the panel of the photo voltaic cells. It is made from mild steel material.

## 3. Connecting wire

It just transfers the current generated by the solar cells to the battery.

## 4. D.C. motor

A 12 V D.C. motor is used is used to run the blower fan. It runs with the help of the current supplied by the battery.

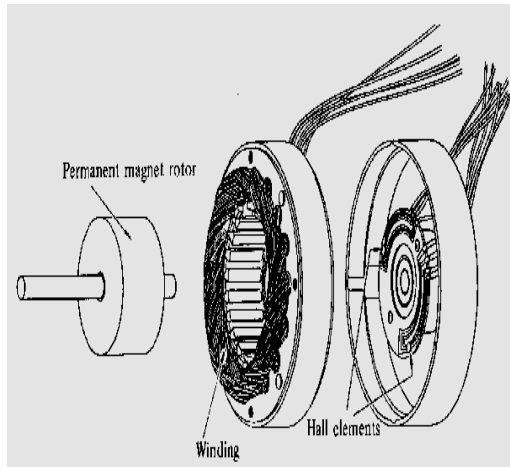

**Fig. 3.0 Exploded view of a D.C. brushless motor**

## 5. Blower

It is just used for providing the necessary force for the spraying of the seed or fertilizers.

## 6. Battery

The function of the battery is to provide current to the D.C. motor for its effective running. The battery used in the device is the lead – acid battery. The positive and negative electrodes of a lead acid battery are immersed in dilute sulphuric acid. Then the battery is fully charged, there is lead peroxide on the positive plate and the spongy lead on the negative plate as the active materials.

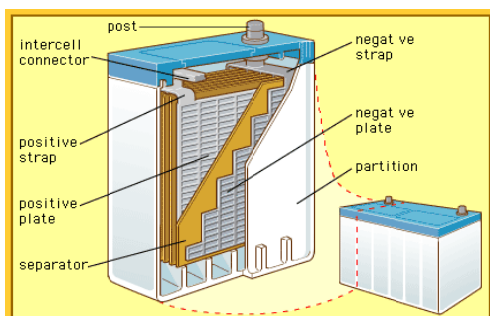

**Fig. 3.0 Exploded view of a general battery**

## 7. Hose

It is used for the connection purposes.

## 8. Hooper

It is a funnel – shaped device where the seeds or fertilizers to be sprayed are stored.

## 9. Adjustable screw

When the speed of the seeds sprayed is to be increased or decreased, it is done with the help of the adjustable screw fitted on the lower part of the hopper.

## 10. Seed splitter

It is the device through which the seeds are sprayed to a particular destination.

## WORKING OF SOLAR POWERED SEED SPRAYER

The blower fan is made to rotate by using a 12 V D.C. motor. The supply of the current is been given from the 12 V lead – acid battery provided. The chemical liquid (seeds or fertilizers) provided in the hooper may reach the nose for the spray by the gravitational force. The panel of photo voltaic cells is fixed by providing the M.S. plates. During the sunshine, the panel board absorbs the heat energy from the sun and it converts it to the electrical energy and sends these current to the battery for the storage provision. The stored energy from the battery is supplied to the motor for operating the blower fan. The discharge of the electrical energy from the battery will be equal to the charging of the battery by the solar photo voltaic cell.

## ADVANTAGES

- Since the efficiency of the sprayer is very high, it can be used by the farmers.
- The materials spread uniformly.
- This device is portable.
- It is light in weight.
- Unskilled workers can also operate it effectively.
- Low operating and maintenance cost.
- This device works on non - conventional energy source (i.e. Sun).
- Maintenance is comparatively easy.
- This device is pollution free as there is no combustion of fuel.
- This device can be used for small and large scale.

## **CONCLUSION**

Today as we are facing the problems of the Global Warming, the concept of the Solar operated Seed Sprayer gives a good alternative for future use. Also this device is much useful in the agricultural countries like India. This device is simple and can be easily operated. Also the results have proved that the working of this sprayer is quite satisfactory for most of the seeds and fertilizers to be sprayed very frequently. Moreover the device can also be modified as per the requirements of the demand by changing the motor and battery capacity. Further developments can also be done in the design of the seed sprayer for increasing the efficiency of the sprayer.

## **REFERENCES**

- [1] C.P. Malik, S.K. Thind and D.S. Bhatia, "Alternating plant archetype with plant growth regulators", Agro's Annual Report of Plant 36 (4), 1995.
- [2] K.K.G. Menon and H.C. Srivastava, "Increasing plant productivity through improved production techniques", 1984.
- [3] C.P. Malik, U. Parmar, P. Singh, K.L. Ahuja and R.K. Raheja, "Henolic acid and aliphatic growth and oil production", Plant Growth Regulation Report – 2, 1985.
- [4] G.D. Rai, "Non – conventional sources of energy".
- [5] Aggrawal, "Solar Energy" an article.
- [6] S.K. Bose, "Solar Energy" an article.



# SOME ASPECTS RELATED TO FLOW SYSTEM TEST AND TURBOMACHINE SELECTION

**Mahesh J. Zinzuvadia,**  
B V M Engg. College,  
Dist. Anand, State- Gujarat,  
VALLABH VIDYANAGAR- 388120

## ABSTRACT

Many industrial applications use combination of Flow system and turbomachine to maintain required fluid flow rate. In these applications power consumption can be minimized by selecting appropriate turbomachine. In this paper, two Flow Systems are tested and potential uses of test results for prediction of Flow system characteristics and in selection of appropriate turbomachine are discussed.

## Introduction

Power consuming fluid machines like pump, blower and fans are required to maintain flow through pipeline, duct or device. Here system made up by using pipeline, fittings and devices is known as Flow system and it is fitted externally with fluid machine.

## CHARACTERISTICS OF FLOW SYSTEM AND OPERATING POINT:

When fluid flows through the Flow system, head loss takes place. The head loss of the Flow system is there due to head loss given by all components of the Flow system. Head loss given by Flow system is also known as its resistance and for given Flow system it depends upon the flowrate through the system. The relationship between flowrate and resistance of Flow system is known as characteristic of flow system[1].

Characteristic of given Flow system can be obtained either analytically or by experimental method. Analytical method is used for simple duct-like system only, while experimental method is used for Flow systems having more complexity. In experimental method, head loss of the Flow system is calculated by using measured values head at inlet and outlet of the Flow system at different flowrates. As resistance of Flow system is proportional to square of flowrate, system characteristic curve will be parabolic.(Fig.1)

When flow system is connected with any power consuming turbomachine, pressure developed by turbomachine should be same as pressure drop of the flow system. This condition is satisfied at Operating point of machine-system combination. Thus operating point is point of intersection of Flow system characteristic and turbomachine characteristic(Fig.1).

Operating point of the machine-system combination may or may not coincide with best efficiency point(b e p).When appropriate turbomachine is selected, Operating point will coincide with b e p and turbomachine will consume minimum power while maintaining required flowrate[2].

## EXPERIMENTAL SET UP AND RESULTS:

The tests were carried out on a Flow system comprising of pipeline, valve and nozzle. Flow system was fitted at blower outlet and flowrate through the Flow system was varied by partial closing of blower inlet in steps. Total head at Flow system inlet and that at Flow system outlet were measured by Prandtl's pitot tube at different flowrates. From the observations resistance of the flow system and flowrate were calculated to obtain Flow system characteristic. Different openings of valve give different flow systems and two such Flow systems were tested. Fig.2 shows experimental results graphically.

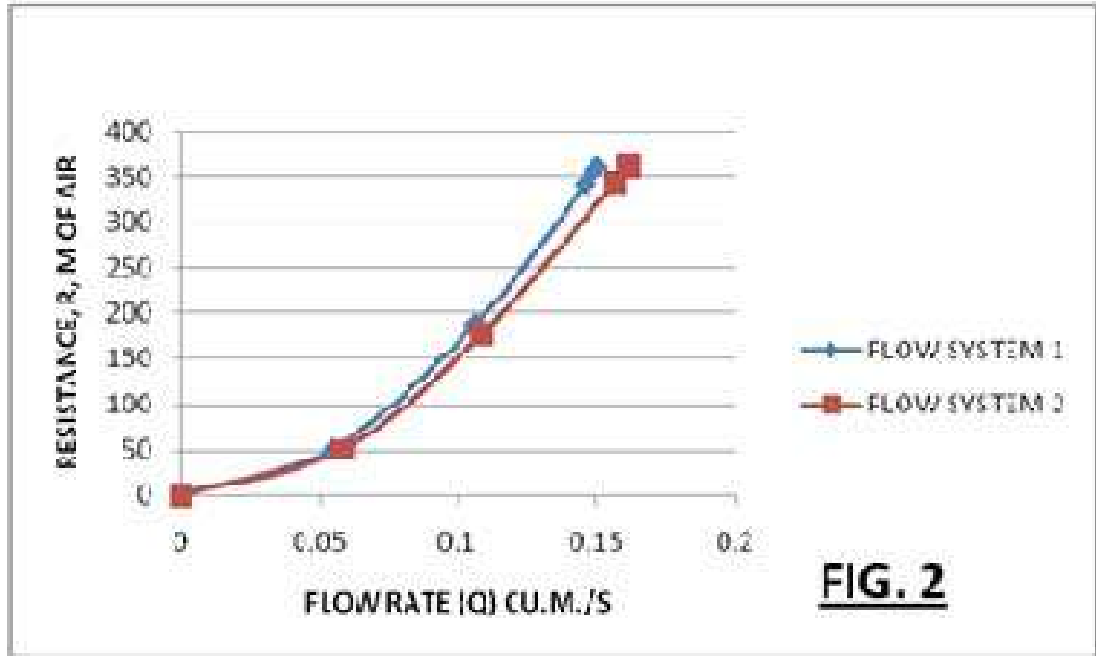
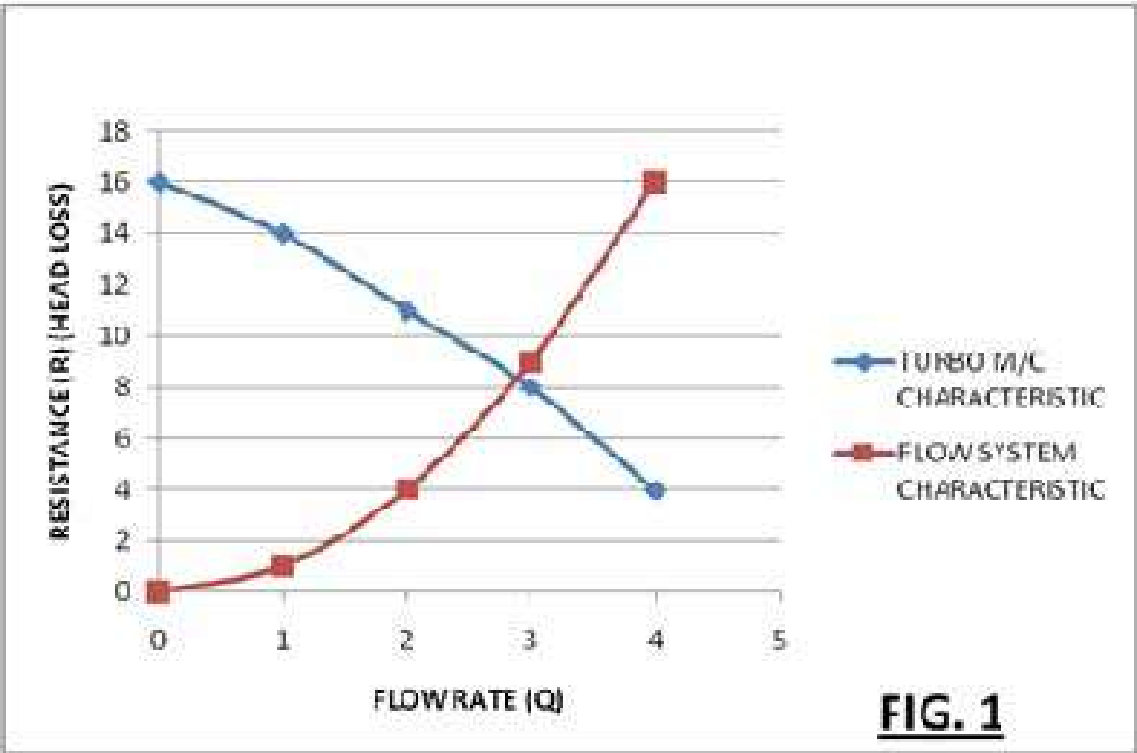

## **DISCUSSION AND CONCLUSION:**

When different Flow systems are obtained by different valve openings, experimental testing can be replaced by suitable method of prediction also. The results obtained here are useful to find accuracy of predicted results.

Characteristics of Flow systems shown in Fig.2 are useful to select appropriate turbomachine to maintain required flowrate. Steps of selection procedure will be as below:

- (1) Obtain system characteristic curve of given Flow system experimentally.
- (2) Considering the application, find required value of flowrate ( $Q_1$ ), e.g. for air-conditioning application, cooling requirement gives necessary air flowrate.
- (3) Find resistance ( $R_1$ ) corresponding to flowrate ( $Q_1$ ) from system characteristic Curve.(Fig.1)
- (4) Select the turbomachine, which has flowrate of  $Q_1$  m<sup>3</sup>/s and head equal to  $R_1$  m at Design point of turbomachine..

## **REFERENCES**

- [1] Essentials of Engineering Fluid Mechanics, Fourth Edition, pp.493-495.  
Reuben M. Olson.
- [2] Introduction to Fluid Mechanics, Fifth Edition, pp.531-540  
Robert W. Fox and Alen T. McDonald.



Platinum Foundation Managed

**GANDHINAGAR INSTITUTE OF TECHNOLOGY**

Approved by AICTE, Affiliated: Gujarat University and Gujarat Technological University

[About Us](#)

[Editorial Board](#)

[GIT Trustees](#)

[Editorial GIT JET  
Message](#)

[Content](#)

[Contact Us](#)

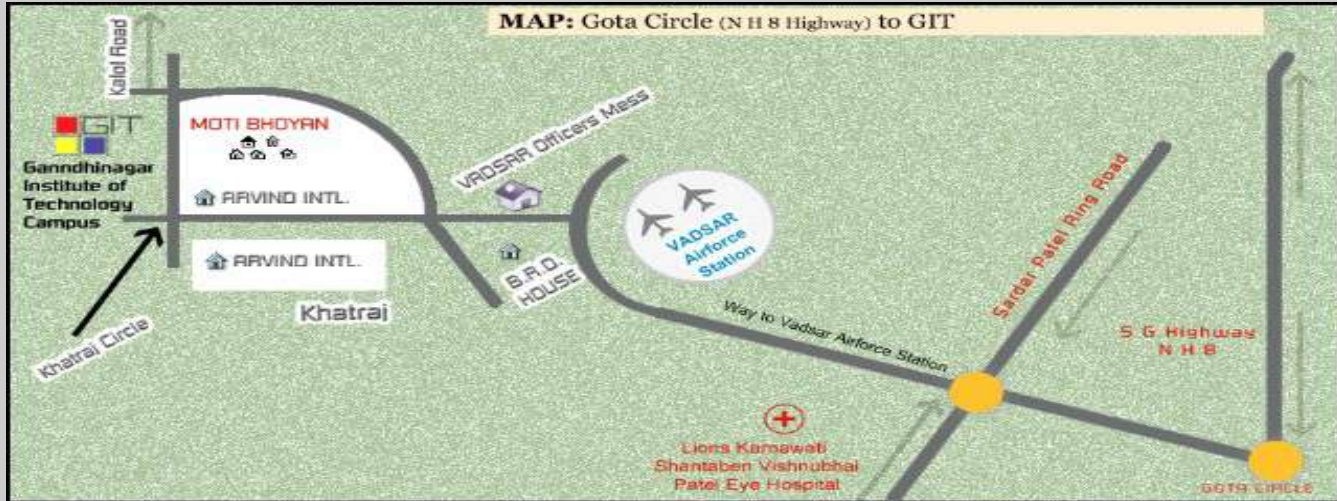

## Contact US

### Address:

Gandhinagar Institute of Technology  
Khatraj - Kalol Road,  
Village Moti Bhojan,  
Tal. Kalol  
Gandhinagar-382721

### Telephone No :

+91-02764-281860  
+91-02764-281861

**E-mail:** [director@git.org.in](mailto:director@git.org.in)

### Fax:

+91-02764-281862



Platinum Foundation Managed

**GANDHINAGAR INSTITUTE OF TECHNOLOGY**

Approved by AICTE, Affiliated: Gujarat University and Gujarat Technological University

[About Us](#)

[Editorial Board](#)

[GIT Trustees](#)

[Editorial GIT JET](#)

[Message](#)

[Content](#)

[Contact Us](#)



## About Gandhinagar Insitute of Technology

Gandhinagar Institute of Technology was established by Platinum Foundation Trust in December 2006. The Institute is affiliated to Gujarat Technological University and Gujarat University and approved by AICTE New Delhi. The Trust is registered under Public Trust Act, having Registration No. E-17490 dated 19 June 2006 at Ahmedabad, Gujarat.

The Institute aims to be a leading center for research and engineering study, pursuing knowledge in both fundamental and applied area, and collaborating closely with business and industry in promoting technological innovation and economic development. The members of the Trust are involved in social activities and are also contributing to the technical institutions development by raising funds and promoting the technical interest of state and country. Gandhinagar Institute of Technology is situated near Village "Moti Bhoyan" and 24 km away from Ahmedabad city.

It offers B.E Program in Mechanical, Electronics & Communication, Computer Engineering & Information Technology and Civil Engineering. It also offers MBA Program with specialization in Marketing, Finance, Human Resource Management and Information Systems. Gandhinagar Institute of Technology will nurture the intellectual growth of its students and serve humanity through creation, application and dissemination of knowledge relevant to technology and become one of the premier Engineering and Management Institutes and achieve the highest order of excellence in teaching.

## EDITORIAL BOARD

- Prof. M. N. Patel* : Principal, L. D. College of Engineering and  
Dean, Faculty of Engineering and Technology  
Gujarat University, Ahmedabad  
Acting Vice-Chancellor, Gujarat Technological University
- Dr. F. S. Umarigar* : Principal, BVM Engineering College and  
Dean, Faculty of Engineering and Technology,  
University, V V Nagar
- Dr. S. A. Puranik* : Director, Atmiya Institute of Science and Technology, Rajkot
- Dr. Ketan Kotecha* : Director, Institute of Technology, Nirma University  
Ahmedabad
- Dr. P. K. Shah* : Director, Silver Oak College of Engineering & Technology  
S.G. Highway, Ahmedabad
- Dr N M Bhatt* : Chairman & Convenor  
Principal, Gandhinagar Institute of Technology,  
Moti Bhoyan, Ta. Kalol, Dist. Gandhinagar

### Disclaimer

Views expressed in the papers are solely from respective authors and editorial board has no responsibility of their authentication

This journal is being published in the interest of research community for private circulation only



[Cdqw"Wu](#)

[Gfkwtken"Dqctf](#)

# I KV"Vtwuvgg)u

[IKV"Vtwuvgg](#)

IKV"Vtwuvgg)u

[Gfkwtken"IKV"LGV  
Oguucig](#)

Uj tk" J ctkuj d jck"D0" Tqj gtc

[Eqvpgv](#)

S wcnkhkecvkqpu <"D0"Eq o

[Eqvcev"Wu](#)

Rqukvkqp <"Og o dgt"/"Dqctf"qh"Vtwuvgg" ( "Cfxkuqt{"Dqctf

Dcemi tqwp f

ì "Rtqr tkgvqt<"Oc j c f g x"Uv g g n"Uw r r n k g t u  
ì "Elq<"Xkpc{"cm"Uv g g n"U{"p f k e c v g  
ì "Elq<"F j k t e l"Uv g g n"Uw r r n k g t  
ì "Elq<"Mtkuj pc"Uv g g n"Vt c f g t  
ì "Qy p g t<"Pc v k q p c n"Uv g g n"Rt q e g u u q t  
ì "Vtwuvgg<"Uck"Xcucpv" I j qv" F c t d e t  
ì "Vtwuvgg<"Lck"Lj w n g n e n" O c p f k t

Uj tk" F k r e m d j c k" P 0" T e x e p k

S wcnkhkecvkqpu <"D0Eq o 0."NN0D0

Rqukvkqp <"Og o dgt"/"Dqctf"qh"Vtwuvgg" ( "Cfxkuqt{"Dqctf

Dcemi tqwp f

ì "Dwukpguu

Uj tk" R t e x k p d j c k" C 0" U j c j

S wcnkhkecvkqpu <"D0C0."NN0D0

Rqukvkqp <"Og o dgt"/"Dqctf"qh"Vtwuvgg" ( "Cfxkuqt{"Dqctf

Dcemi tqwp f

ì "Rtqkf g p v" q h" \ c n e x c f" U c o c l" L c k p" U g x c" V t w u v  
ì "Vtwuvgg" q h" Xcucpv" C v o c" E j c t k v e d n g" V t w u v  
ì "Vtwuvgg" q h" T e o r w t e" E j c o r c" X k l { c" J q u r k v e n  
ì "Vtwuvgg" q h" U j e p v k x e p" ( "C o d e y c f k" L c k p" U c p i j  
ì "Vtwuvgg" q h" T e o r w t e" M g n e x e p k" O e p f e n  
ì "Vtwuvgg" q h" R c o r w t e" R e p l t e r q n g" V t w u v

Uj tk" I c j c p u j { c o d j c k" X 0" V j e m m e t

S wcnkhkecvkqpu <"O0C

Rqukvkqp <"Og o dgt"/"Dqctf"qh"Vtwuvgg" ( "Cfxkuqt{"Dqctf

Dcemi tqwp f

ì "Rtqhguuqt"cv"Xkxgmcpfp"Eqnngig"qh"Ctvu."Cj o g f c d e f  
ì "Gz0"O0N0C0." I w l e t e v" C u u g o d e n { " h t q o" O c p f e n  
ì "Vtwuvgg" q h" X 0" O 0" V j e m m e t" E j c t k v e d n g" V t w u v." C j o g f c d e f  
ì "Oe p c i g u" O w m v l g g x c p" X k f j { c n c { c" c p f" D X F" J k i j" U e j q q n." K u c p r w t" c p f" O c p k p e i c t



ì"Cfxkuqt!Og o dgt"Mcpmctk"Ocpkpcict"Peictkm"Ucjemctk"Depm  
ì"Fktgevqt"/"Cfctuj"Eq/Qrgtcvkxg"Frctv o gpcn"Uvqtgu

U o v"Xctuj cdgp"O0"Rcp f j k

S wcnkhkecvkqpu <"D0Eq o

Rqukvkqp <"Og o dgt"/"Dqctf"qh"Vtwuvgg" ("Cfxkuqt{"Dqctf

Dcemi tqwpf

ì"Yqtmkpi "gzrgtkgpeg"kp"vjg"hkgnf"qh"Kpuwtcpeg"cpf"Kpxguv o gpv"Cfxkuqt{"hqt"cdqww"42"{gctu



## Research Methods

**Research** is another word for gathering of information. The more information we have the closer we get of making our own decision. Research is the result of advancing knowledge created in the past. There are people from all walks of life that contribute to gathered information. These are ordinary people and extraordinary people. They include teachers, students, scientists, professors, scholars, business owners, librarians, book keepers, writers, politicians and many more unknown out there.

Research is designed to solve a particular existing problem so there is a much larger audience eager to support research that is likely to be profitable or solve problems of immediate concern. We also must understand how research impacts our decision making. Most people make decisions without gathered information to back them up. Only few do. Research requires time, effort, and sometimes money to have the evidence you need to make a sound decision that's why many avoid it. The research you do and evidence you gathered will have impact on your future. Be advised, considered the risks or consequences of making an important decision with inadequate evidence.

In conclusion research is very vital to our everyday decision making. It arms you from wrong information and save time and money. It is important to your success as you take on life's challenges and career decisions making. But be careful though, because too much research without action on what you're learning is not good either. The question is how much information is enough? How much information can you afford? Research plus action will most likely guarantee a successful research.

There are five fundamental research methods viz. (1) Experimental methods (2) Correlations (3) Naturalistic observation (4) Survey and (5) Case Study.

**Experimental Methods:** This method is one in which a researcher manipulates a variable (anything that can vary) under highly controlled conditions to see if this produces (causes) any changes in a second variable. The variable, or variables, that the researcher manipulates is called the independent variable while the second variable, the one measured for changes, is called the dependent variable. Independent variables are sometimes referred to as antecedent (preceding) conditions. All scientific disciplines use this method because they are interested in understanding the laws (cause-and-effect relationships) of nature. The power of the experimental method derives from the fact that it allows researchers to detect cause-and-effect relationships.

In order to see cause-and-effect relationships the researcher must be sure that his manipulations (the independent variable) are the only variables having an effect on the dependent variable. He does this by holding all other variables, variables that might also affect the dependent variable, constant (equivalent, the same). Only by this highly controlled procedure can the researcher be sure that the observed changes in the dependent variable were in fact caused by his manipulations. Experimental studies, therefore, are used when the researcher is interested in determining cause-and-effect relationships. Also, this method can be used when it is appropriate, both practically and ethically, to manipulate the variables.

However, a major limitation is that this method can only be used when it is practical and ethical for the researcher to manipulate the antecedent conditions. A second limitation to this method is that experimental studies are usually done in the highly controlled setting of the laboratory. These conditions are artificial and may not reflect what really happens in the less controlled and infinitely more complex real world.

**Correlations:** Correlation is classified as a non-experimental, descriptive method. The reason for that is because variables are not directly manipulated as they are in the experimental method. Although correlation is often described as a method of research in its own right, it is really more of a mathematical technique for summarizing data, it is a statistical tool. A correlational study is one designed to determine the degree and direction of relationship between two or more variables or measures of behavior.

The strength of this method lies in the fact that it can be used to determine if there is a relationship between two variables without having to directly manipulate those variables. In other words, correlation can be used when the experimental method cannot; correlation can be used when it is impractical and/or unethical to manipulate the variables. Correlation also can be used as a basis for prediction.

The greatest limitation of correlation is that it does not tell researchers whether or not the relationship is causal. In other words, correlation does not prove causation. It only shows that two variables are related in a systematic way, but it does not prove nor disprove that the relationship is a cause-and-effect relationship. Only the experimental method can do that.

**Naturalistic observation:** The naturalistic observation is a type of study classified under the broader category of field studies; non-experimental approaches used in the field or in real-life settings. In the naturalistic observation method the researcher very carefully observes and records some behavior or phenomenon, sometimes over a prolonged period, in its natural setting. The subjects or phenomena are not directly interfered with in any way. In the social sciences this usually involves observing humans or animals as they go about their activities in real life settings. In the natural sciences this may involve observing an animal or groups of animals or some physical phenomena, such as the eruption of a volcano.

The major strength of this method is that it allows researchers to observe behavior in the setting in which it normally occurs rather than the artificial and limited setting of the laboratory. Further uses might include studying nature for its own sake or using nature to validate some laboratory finding or theoretical concept.

One of the limitations is that this is a descriptive method, not an explanatory one. That is, without the controlled conditions of the laboratory, conclusions about cause-and-effect relationships cannot be drawn. Behavior can only be described, not explained. This method can also take a great amount of time. Researchers may have to wait for some time to observe the behavior or phenomenon of interest. Further limitations include the difficulty of observing behavior without disrupting it and the difficulty of coding results in a manner appropriate for statistical analysis.

**Survey:** The survey, another type of non experimental, descriptive study, does not involve direct observation by a researcher. Rather, inferences about behavior are made from data collected via interviews or questionnaires. Interviews or questionnaires commonly include an assortment of forced-choice questions (e.g. True-False) or open-ended questions (e.g. short answer essay) to which subjects are asked to respond. This sort of data collection is sometimes referred to as a self-report. Surveys are particularly useful when researchers are interested in collecting data on aspects of behavior that are difficult to observe directly and when it is desirable to sample a large number of subjects. Surveys are used extensively in the social and natural sciences to assess attitudes and opinions on a variety of subjects.

The major limitation of the survey method is that it relies on a self-report method of data collection. Intentional deception, poor memory, or misunderstanding of the question can all contribute to inaccuracies in the data. Furthermore, this method is descriptive, not explanatory, and, therefore, cannot offer any insights into cause-and-effect relationships.

**Case study:** This method is also a non-experimental, descriptive type of study. It involves an in-depth descriptive record, kept by an outside observer, of an individual or group of individuals. This often involves collecting and examining various observations and records of an individual's experiences and/or behaviors. Typical data collected might include biographical data, medical records, family history, observations, interviews, and the results of various psychological tests.

Case studies are particularly useful when researchers want to get a detailed contextual view of an individual's life or of a particular phenomenon. Case studies are also useful when researchers cannot, for practical or ethical reasons, do experimental studies.

This is a descriptive method, not an explanatory one. That is, without the controlled conditions of the laboratory, conclusions about cause-and-effect relationships cannot be drawn. Behavior can only be described, not explained. Case studies also involve only a single individual or just a few and therefore may not be representative of the general group or population. Also, much of the information collected is retrospective data, recollections of past events, and is therefore subject to the problems inherent to memory.

Dr N M Bhatt  
Principal

Cdqw"Wu  
 Gflvqtken"Dqctf  
 IKV"Vtwvvgu  
 Gflvqtken"IKV"LGV  
 Oguucig  
 Eqpvpgv  
 Eqpicev"Wu

Utl0	Vkvng"qh"Rcrgtu	Cwvjqt	Kpukvkvkqp	G/o ckn"KF
3	<a href="#">Cktq Uvcike"Uvcidknv{"Cpen{uku"qh"Napj Urp"Uwurgpukqp"Ditf i gu</a>	Rtqh0"Pktcl"ujcj Cuuqekcvg"rtqhguaqt cpf"jgcf	Ejctqvct"Kpukvkvwv"qhVgejppnqi {. Ejeptic	pktclujcj lex B geejcpiclcclckp
4	<a href="#">Hnqgfkpi"kp"Eqo rwygt"Pgvyqtm"Ykvj Reuukxg"Enwvgtkpi</a>	Otu0"Fcujepc"Okvut{	Eqo rwygt"Gpikpggtkpi" Fgrv0. Icpfjkpcict"Kpukvkvwv"Qh Vgejppnqi {. Icpfjkpcict	fcujepcclokvut{ B ikv0qti0kp
5	<a href="#">Cp"Deugf"Kpvgmkigp"EqpvtqmgTuHqt"Cp kpfktgev"Xgevt"Eqpvtqmgf"Vjtg/Rjcuq kpfwekqp"Ovqt</a>	Cok"Rcvg. Cuukvcpv"rtqhguaqt Vglgpfte"Rcvg. UwtcvR0I0"Uwvfgpv	UXPKV.Uwtcv	cokagpi i : 8B {cjqqleqo coklo ikvgt B i ocknleqo
6	<a href="#">Eqo rctevkxg"Uwvf{"qh"Ygd"Ugtxlegu"cpf Uqhvycg"qtkgpvgf"Ctejkvewtg"ht Oqdkng"Cwi o gpvgf Tgcnkv{"U{uvgo</a>	Lvkp"Ujcej."OEC."Tgugtej Uejqct."FT0"Dklgpfte"Citcycn Rtpekrca	XMOU"Eqnngig."Xcfw	lvkpujcej9; oec B i ocknleqo." dklgpfteacitcycn B {cjqqleqo
7	<a href="#">SWGUV"Swkem"Wpdkcugf"Ghhekgpv Uvcikvkecn"Vtgg+&lt;"Cp"ghhekgpv"cn i qtkvj o qh Encuukhkecvkqp"Vtgg"kp"Feve"Okpki</a>	Otl"W0"P0"Rctoct."Otl"C0"M0 Tcprwtc."Otl"X0"M0"Lfglc."Otl"T0 R0"Lqujk	EEGV."Ycfjycp."Iwlctcv0	wtgurctoct35B {cjqqleq0kp. "xmlefglcakvyqtnf B {cjqqleq0kp. tcj3; : 7B i ocknleqo
8	<a href="#">Rgthqto cpeg"Cpen{uku"qh" Iwp/ujqv Ektgevkqp" Fgvgevkqp"U{uvgo"ht"cm69"iwp ujqv</a>	Cplw"O0"Xcufgyepk Ftl"l0T0mwmmctpk"l0U0Icltg	E0W0Ujcej"Eqnngig"qh"Gpikpggtkpi ("Vgejppnqi {. Ycfjycp"Elv{	"itmwmctpk4; 486B tgfkh ocknleqo" tcmgujcltg B i ocknleqo
9	<a href="#">Oqfkhkf""Dei ikpi Ogviqf&lt;"C" Pqxcn Crrtqcej"qh"Owvkrng"Encuukhkecvkqp"kp Feve Okpki</a>	Otl"Wtguj" P"Rctoct Otl"Mtwpca" I"Rcvg."Ou"Oggpcmujk	E0E0G0V."Ycfjycp."Iwlctcv. Kpfkc	wtgurctoct35B {cjqqleq0kp mi r4225B i ocknleqo" oggpemujkluctajc B i ocknleqo
:	<a href="#">Gokukqp Uegpctq"Cv" Tqcf"Kpvtugevkapu &lt; C"Ecug"Uwvf{"Oh"Uwtcv"Elv{</a>	Lc{guj"C0Ujcej FtlH0U0Wotkict Ftl"l0D0\cnc."Pggtel"l0Ujctoc	X0D0V0Gpi i0 Eqnngig."WotcmjD0X0"Gpi i0 Eqnngig."X0Xkf{cpicict	
:	<a href="#">Rgthqto cpeg"Eqo rctkuq"qh"Urceg"Vko g Eqfgu</a>	Otu0"Cpujw"Ujcej	Icpfjkpcict"Kpukvkvwv"Qh Vgejppnqi {. Icpfjkpcict	cpujw0ujcj B ikv0qti0kp
32	<a href="#">Feve Okpki&lt;"Vgtou"Cpf"Vgejpkswgu</a>	Otl"Wtguj" P"Rctoct. Otl"Mtwpca" I0"Rcvg. Ou0Oggpcmujk"Uctqjc."Otl"Pkujkfj U0"Ejcxfc	Cuu0"Rtqh0."KV" Fgrctvogpv. EEGV."Ycfjycp."Iwlctcv."Kpfkc Ngewtgt."KV" Fgrctvogpv."MKVTE. Mcaqn."Iwlctcv."Kpfkc"Cuuv0"Rtqh0. EG" Fgrctvogpv."EKV."Ejeptic. Iwlctcv."Kpfkc	wtgurctoct35B {cjqqleq0kp. mi r4225B i ocknleqo . oggpemujkluctajc B i ocknleqo . pkujkfjejcxfcleg B geejcpiclcclckp
33	<a href="#">Uqog Curgeu" Tgncvfg"vq HnqyU{uvgo Vguv"cpf"Vwtdqocejkgp Ugngevkqp</a>	O0"l0\kp wxcfk.Ngewtgt.	D"X"O"Gpi i0"Eqnngig.Xcncd j Xkf{cpicict	o1 dxo B i ocknleqo
34	<a href="#">Orvoklgf"Twoqt" Tqwkpi" Cniqtkvj o"ht Yktnguu"Ugputq" Pgv yqtmu</a>	\cncm"Oqfk. Uwpln"lctfquj."Rtqh0"Rtedjcv" Tcplep	Icpfjkpcict"Kpukvkvwv"qh Vgejppnqi {. Icpfjkpcict	cncmaoqfk4222B {cjqqleqo
35	<a href="#">Hcdtkcvkqp"qh"Ocetqrqg"Cttc{"ap Uknkeq</a>	Otl" Cok" T"UjctocCuuv"Rtqhguaqt	Icpfjkpcict"Kpukvkvwv"qh Vgejppnqi {. Icpfjkpcict	cokvujctoc B ikv0qti0kp
36	<a href="#">Cpcpn{uku"qh"Ocipgkve" Hnwkf"Deugf Uswgglg" Hkn o" Dgv yggp"Vyq" Ewtxgf Ektewict" Rncvgu</a>	Otl" Pkmjkn" Cdjcpik". Otl" Ejeptic Ejepticgnc	Icpfjkpcict"Kpukvkvwv"qh Vgejppnqi {. Icpfjkpcict	pkmjkn0cdjcpik B ikv0qti0kp ejepticgnc B ikv0qti0kp
37	<a href="#">Crrnkecvkqp"qh"Uqct" Rqygtgf"Uggf Urte{gt"kp" C i tkewvvtg/" Cp" Oxtxky</a>	Otl" Okncp" L0" Rcpf{c." Otl" Ujckxcn T0" Rctkmj	Icpfjkpcict"Kpukvkvwv"qh Vgejppnqi {. Icpfjkpcict	okncp0rcpf{c B ikv0qti0kp

# AEROSTATIC STABILITY ANALYSIS OF LONG SPAN SUSPENSION BRIDGES

N D Shah<sup>1</sup> D A Shah<sup>2</sup> Dr J A Desai<sup>3</sup> H S Patil<sup>4</sup>

1. Associate Professor & Head, Civil Dept., Charotar Institute of Technology, CHARUSAT, Changa.

2. Lecturer, Civil Department, Charotar Institute of Technology, CHARUSAT, Changa.

3. Director, C G Patel Institute of Technology, Bardoli – 394 350.

4. Professor, Applied Mechanics Department, SV National Institute of Technology, Surat – 395 007.

[nirajshah.cv@ecchana.ac.in](mailto:nirajshah.cv@ecchana.ac.in)

**ABSTRACT-***Deflection theory is the basic theory of cable and stiffening girder suspension bridges. Geometric nonlinearity of suspension bridges due to dead load is taken in to account in this theory. Geometrical changes are having significant effects in suspension bridges, so it cannot be neglected in preliminary analysis of suspension bridges. Series method is a new method for the deterministic aerostatic stability analysis of suspension bridges. The geometric nonlinearity in the deflection theory and the three components of displacement-dependent wind loads are taken into account in the method. A computer program for calculating change in various geometric parameters of stiffened suspension bridges is developed using HTML. Again another computer program for finding a critical wind velocity of suspension bridges was developed using MATLAB.*

## KEY WORDS

Aerostatic Stability, Suspension Bridge, Nonlinearity, Displacement Dependent Wind Load

## 1. INTRODUCTION

The basic design of a suspension bridge has been in use for centuries: thousands of years ago, people crossed waterways and chasms by swinging hand over hand on suspended cables. Later, walkways were hung from the cables to make the process easier, and the original vines and ropes began to be replaced with chains. Major bridges were still built using a truss design until 1808, when an American inventor named James Finley filed a patent on an early version of a suspension bridge. Finley's design involved stretching two strong chains over the top of several towers and anchoring them on either side of the bridge. He hung lesser chains from the two master chains and used them to suspend a rigid deck, and the modern incarnation of the suspension bridge was born.

A suspension bridge is a type of bridge which is built by suspending the roadway from cables attached to a master cable which runs above the length of the bridge. In addition to being

strong and lightweight, suspension bridges are also beautiful, and some of the most famous bridges in the world are also suspension bridges, including San Francisco's iconic Golden Gate Bridge and New York's Brooklyn Bridge. The design of a suspension bridge is simple and straightforward, and takes advantage of several techniques to distribute the weight of the bridge safely and evenly.

Suspension Bridges have received more attention due to their ability to cover the large spans. For bridging the long and unsupported spans, the Suspension Bridges present the most elegant and efficient structural solution. And hence, they are increasingly being constructed all over the world. Thus, there is a need for developing a comprehensive understanding about the detailed behavior of these bridges. Also, they are one of the costliest civil engineering projects, and hence necessitate much attention while its analysis and structural design stage. Therefore, it is imperative that a reliable analysis should be available. With the increasing central span length of suspension bridges, it becomes especially important to understand the aerostatic behavior of suspension bridges.

## 2. THEORY OF STIFFENED SUSPENSION BRIDGES & VERIFICATION

In the theory of cable and stiffening girder systems the geometrical relations between the positions and dimensions of a given element of the cable in the initial and deflected configuration is taken in to account. As shown in Fig. 1 an element of cable length is defined by  $cd$  subtends a length  $ab$  when not deflected. After deflection the point  $c$  and  $d$  move to new position  $c'$  and the length  $c'd'$  is in general not equal to  $cd$ . The vertical deflection of  $c$  is denoted by  $y_c$  and the lateral shift of the same point is  $x_c$ . The suspenders which connect  $cd$  to  $ef$  in the initial configuration, are attached to  $c'd'$  in the deflected position since  $c'$  and  $d'$  are the new positions of  $c$  and  $d$ . The deflection of the girder at  $e$  is denoted by  $y_e$  and is equal to the sum of  $y_c$  and  $y_d$  and changes due to the suspenders.

Structural details decide whether g shall be vertically below e and are discussed later. The slope of the undeflected cable is

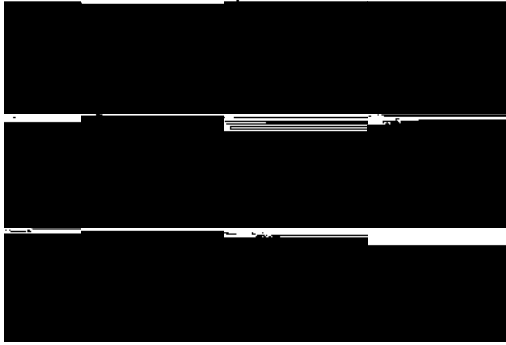

**Fig. 1: Cable Element**

Equations for calculating deflection of suspended main cable, deflection of girder, slope of undeflected cable in initial position and forces in suspenders of any finite element cable based on basic deflection theory of suspension bridges are as follows:

Lateral shift of cable element:

$$\delta = \frac{Hw}{EA} \sec \phi \left[ \frac{4a^2 f}{l} \right] \sin 2\phi z / 4z \quad (1)$$

Vertical deflection of cable element:

$$\xi = a_2 \sin 2\phi z \quad (2)$$

Initial slope of undeflected cable:

$$\Phi = \tan^{-1} \left[ \frac{4f}{l} \right] \sin 2\phi z \quad (3)$$

Deflection of stiffening girder:

$$\tau = a_2 \sin 2\phi z \quad (4)$$

Forces in the suspenders:

$$F_h = \left[ \frac{Hw}{EA} \left( \frac{8f}{l^2} + \frac{4\phi^2}{l^2} a_2 \sin \frac{2\phi x}{l} \right) \right] \left[ \frac{w_1}{2} \right] \quad (5)$$

Horizontal component due to dead load:

$$H_w = \frac{wl^2}{8f} \quad (6)$$

Where,

E=Modulus of elasticity of cable, A=Area of cable, f=Sag of the cable, a<sub>2</sub> =Maximum deflection of structure, l= Length of

main span, h<sub>s</sub>=Hanger spacing, w= weight of main span, w<sub>1</sub>= weight of cables, suspenders etc. in main span

JavaScript is an object-oriented scripting language used to enable programmatic access to objects within both the client application and other applications. It is primarily used in the form of client-side JavaScript, implemented as an integrated component of the web browser, allowing the development of enhanced user interfaces and dynamic websites. JavaScript is a dialect of the ECMA Script standard and is characterized as a dynamic, weakly typed, prototype-based language with first-class functions. JavaScript was influenced by many languages and was designed to look like Java, but to be easier for non-programmers to work with.

A computer HTML program is developed for calculating change in various geometrical parameters due to dead load of Stiffened Suspension Bridges. Main feature of program is, it can simulate graphical presentation of deflected shape. Its accuracy has been checked by numerical example.

Properties of the main span of the Golden Gate Bridge at San Francisco are as under:

Length of Main Span= 4,200 ft. , Sag of Main Span= 470 ft. , Length of Side Spans= 1,125 ft. , Weight of Main Span per lineal ft. Deck= 1,11,300 lbs., Weight of Cables, Suspenders etc.= 6,670 lbs., Weight of Stiffening Trusses= 3,330 lbs., Weight of Bracing= 600 lbs., Weight of Miscellaneous= 400 lbs., Total Weight =21,300lbs., Dead load for side spans per linear ft.= 21,500 lbs., Live load capacity per linear ft.= 4,000 lbs., Maximum downward deflection of Main Span= 10.8 ft., Longitudinal Tower deflections Shoreward= 22 ins., Longitudinal Tower deflections Channel ward= 18 ins. Diameter of Cables over wrapping= 36-f ins., Length of one cable= 7,650 ft., Number of wires in each cable= 27,572, Size of wire, diameter= 0.196 ins., Weight of cable, suspenders etc.= 24,500 tons., Moment of Inertia of one main stiffening girder= 43,150 in<sup>4</sup>.

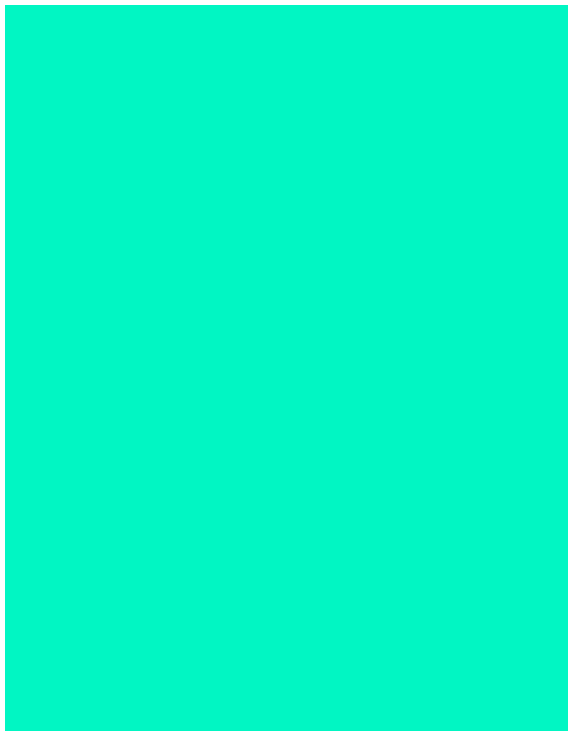

size and shape of the bridge, the terrain, and the gust characteristics. Aerostatic loads form a major component of lateral loads that act on all structure. In general, they are a component of the so called environmental loads to which all structures are subjected. Because of the long spans, suspension bridges have become increasingly sensitive to aerostatic instability. On the other hand, experimental observations suggest that the aerostatic instability of long-span bridges (suspension bridges and cable-stayed bridges) can occur under the action of static aerostatic loads. Therefore, the aerostatic stability analysis of long span suspension bridges under the aerostatic loads is of considerable importance.

#### 4. DETERMINISTIC AEROSTATIC STABILITY ANALYSIS OF SUSPENSION BRIDGES

A series method is proposed by Jin Cheng, Jian-Jing Jiang, Ru-Cheng Xiao [10] to overcome drawbacks of existing deterministic methods for aerostatic stability analysis of suspension bridges. Series method is also proposed to investigate the aerostatic stability of suspension bridges using a hybrid method, consisting of the series method and direct Monte Carlo simulation. Presented series method contains the following characteristics:

1. The series method considers both three components of displacement-dependent wind loads and geometric nonlinearity of structure in the deflection theory of suspension bridges.
2. The following derivation of formula is based on the deflection theory of suspension bridges.

This is mainly because this theory can, to a certain extent account for the geometric nonlinearity of structure (the stiffening effect of the tension force in the cable). This conclusion has been demonstrated by the fact that the majority of the existing long span suspension bridges were correctly designed using the deflection theory before the computer era.

#### 5. ASSUMPTIONS MADE IN THEORY

In the above theory, the following assumptions are made:

1. Hanger is densely distributed along the bridge length direction;
2. The stretching of hangers under wind loads is ignored;
3. Changes of critical wind velocity caused by longitudinal deformation and lateral deflection of stiffened girder are ignored;

#### 3. AEROSTATIC ANALYSIS

Bridges are frequently built on exposed sites and are subject to severe wind conditions. Aerostatic loads on bridge superstructures depend on the type of bridge, such as slab-stringer, truss, arch, cable-stayed, or suspension. Other parameters that affect aerostatic loads on bridge superstructures are the wind velocity, angle of attack, the

Vertical Cable Deflection		Girder Deflection	
Paper Results:[2]	Our Results	Paper Results:[2]	Our Results
<b>z</b>		<b>z</b>	
0	24°7'	0	0.000
0.1	19°42'	0.1	5.877
0.2	15°2'	0.2	9.510
0.3	10°9'	0.3	9.510
0.4	5°7'	0.4	5.877
0.5	0°0'	0.5	0.000
0.6	5°7'	0.6	-5.877
0.7	10°9'	0.7	-9.510
0.8	15°2'	0.8	-9.510
0.9	19°42'	0.9	-5.877
1.0	24°7'	1.0	0.000

4. Configuration of cable during on completion is quadratic parabola; stress of stiffened girder due to dead load is ignored and
5. Under the action of drag force of displacement-dependent wind loads, the load transferred to the stiffened girder from cables is assumed to be isosceles triangle distribution.

## 6. SERIES METHOD

The series method is a two-step process: the calculation of deflection response under the displacement-dependent wind loads and the calculation of the critical wind velocity. The response under the displacement-dependent wind loads is calculated from Fourier series. The critical wind velocity is calculated by means of an iterative method. It is found that a small number of iteration cycles and Fourier coefficients are sufficient enough for convergence. The series method is suitable for single-span suspension bridges.

## 7. Three components of wind loads

The three components of wind load are drag force, lift force and pitch moment. Consider a section of bridge deck in a smooth flow, as shown in Fig. 2. Assuming that under the effect of the mean wind velocity  $V$  with the angle of incidence  $\theta$ , the torsional displacement of deck is  $\delta$ . Then the effective wind angle of attack is  $\alpha = \theta + \delta$ . The components of wind forces per unit span acting on the deformed deck can be written in wind axes as:

$$\text{Drag force: } F_x(\alpha) = 0.5 \rho V^2 C_x(\alpha) D \quad (7)$$

$$\text{Lift force: } F_z(\alpha) = 0.5 \rho V^2 C_z(\alpha) D \quad (8)$$

$$\text{Pitch moment: } M(\alpha) = 0.5 \rho V^2 C_m(\alpha) B^2 \quad (9)$$



**Fig 2: THREE COMPONENTS OF WIND LOADS  
IN DIFFERENT AXES**

## 8. SOLUTION PROCEDURE

1. Calculate the initial horizontal component of cable tension owing to dead loads of cables, hangers and stiffened girder from

$$H_0 = \frac{ql^2}{8f}$$

2. Give an initial wind velocity  $V$
3. Initialize the iteration counter  $i = 1$ .
4. If  $i = 1$ , the coefficient  $b_{ri} = 0$ ,  $H_{pi} = 0$ , and  $H_i = H_0$  in Eq. (13).
5. Determine the coefficient  $a_{ri}$  by substituting  $b_{ri}$ ,  $H_{pi}$  and  $H_i$  into Eq. (13).
6. Calculate the vertical displacement of stiffened girder,  $v(x)$ , from (10).
7. Set  $i = i + 1$ .
8. Substitute  $v(x)$  into (9), and the new value of  $H_{pi}$  is determined.
9. Let  $H_i = H_0 + H_{pi}$
10. Substitute  $H_i$  into (7), and the coefficient  $b_{ri}$  is determined.
11. Calculate the torsional displacement of stiffened girder,  $\delta(x)$ , and the vertical displacement of stiffened girder,  $v(x)$ , and the lateral displacement of stiffened girder,  $u(x)$ , from (4), (10), (18) and (19), respectively.
12. Check the convergence value  $\epsilon_1$  using

$$\epsilon_1 = \left| \frac{H^i - 4H^{i-1}}{H^{i-1}} \right|$$

13. If  $\epsilon_1 > \epsilon_{1max}$ , go to step 5. If  $\epsilon_1 < \epsilon_{1max}$ , continue.
14. Check the convergence using
15. Check if  $H^i$  has a negative value.
16. If  $H_i$  is a positive value, update the wind velocity  $V$  using
17.  $V = V + \Delta V$
18. Where  $\Delta V$  is the incremental wind velocity, go to step 2;

	m (t/m)	E(MPa)	
Steel box girder	18.33	210000.0	0.3
Cable	2.397	200000.0	-
Hanger	0.172	160000.0	-

19. Otherwise, STOP (end of calculation).

The flowchart for the same is as shown in Fig. 3.



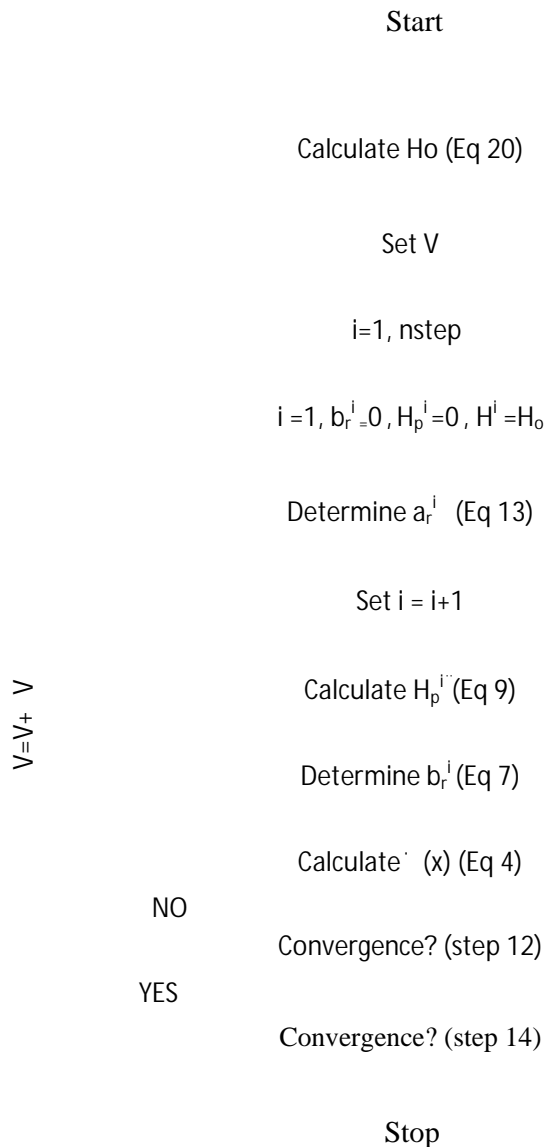

**Fig 3: FLOW CHART FOR SOLUTION PROCEDURE**

**9. VERIFICATION EXAMPLE**

The Hu Men suspension bridge in China was chosen for verification example. The general configurations of the bridge, shown in Fig. 5.03, are summarized as follows: a suspension bridge of main span 888 m; portal frame shape towers with 150 m height; closed-box deck with 3.012 m depth and 35.6 m width; width between center lines of cables is 33 m; the spacing between the two hangers is 12.0 m. section material and geometrical features of the main member are indicated in Table 1.

**Table 1: SECTION GEOMETRICAL AND MATERIAL FEATURES**

The three components of the displacement-dependent wind loads were only considered for the bridge deck while for the cables only the initial drag force was considered. The angle of incidence  $\theta = 0$  is taken. The coefficients ( $e_1, e_2, c_1, c_2$ ) are given by  $e_1 = 0.00877, e_2 = 0.01838, c_1 = 0.02462, c_2 = 0.0789$ . Sag of the cable is 143 m. Drag force acting on the towers was not considered.

Comparison of different methods result for critical wind velocity is shown in table 4.02. From this table it can be seen that presented series method result using matlab-7.0 is nearly equal to paper result. And quite satisfactory result in the prediction of critical wind velocity can be obtained by using MATLAB program. And <5% difference with respect to accurate critical wind velocity calculated by different methods as shown in Table 2.

Fig 4 shows horizontal tension in cable vs. wind velocity. From this fig it can be seen that horizontal tension in cable decreases with increase in wind velocity. And for a particular wind velocity it gives negative value. It indicates critical wind velocity, which may causes instability in suspension bridge.

**Table 2: RESULT COMPARISON FOR CRITICAL WIND VELOCITY**

	PAPER RESULT			MATLAB-7.0 RESULT
	NFE M	LINEAR METHOD	SERIES METHOD	SERIES METHOD
Critical Wind Velocity (m/s)	120.0	136.0	125.0	123.0



**Fig 4: HORIZONTAL TENSION VS. WIND VELOCITY**

## 10. Conclusions

From this work following conclusions can be drawn:

1. Series method gives very precise results compared to NFEM and linear method, the difference is @ <5% with respect to accurate critical wind velocity. Hence, series method is suggested for higher spans.
2. The results show that the developed program is accurate, practical, and computationally efficient.
3. By using series method, the problem of aerostatic analysis is greatly simplified, thus saving of computation time significantly.
4. Vertical deflection and lateral shift of main cable element is having significant effect in deflected configuration of stiffened suspension bridges.
5. To determine longitudinal movement of the girder, due to the inclination of the suspenders it is necessary to know the forces in the suspenders.
6. Salient feature of HTML program is, it can simulate deflected shape of a cable element at various distances from tower.

## 11. References

1. B. Semper "A Mathematical Model Suspension Bridge Vibration", *Math1. Computer Modeling*, Vol. 18, No. 11, pp. 17-28, 1993.

2. Dino A. Morelli "Some Contribution To The Theory Of The Stiffened Suspension Bridges"
3. E.S. Kreis, J.C. Andr "A Numerical Inquiry into The Flutter Phenomenon in Long-span Bridges", *Latin American Journal of Solids and Structures*, 2 (2005) 321–337
4. Haifan Xiang, Yaojun Ge "Refinements on Aerodynamic Stability analysis of Super Long-span Bridges" *Journal of Wind Engineering and Aerodynamics*, Elsevier, 90 (2002) 1493–1515,
5. H. Erdogan, E. Gulal "The Application of Time series analysis to Describe the Tynamic Movements of Suspension Bridges", Elsevier , *Nonlinear Analysis: Real World Applications* 10 (2009) 910–927.
6. Henrik Ditlev Nissen, Paul Haase Sorensen.and Ole Jannerup "Active Aerodynamic Stabilisation of Long Suspension Bridges", Elsevier , *Journal of Wind Engineering and Industrial Aerodynamics* 92 (2004) 829–847.
7. Jin Cheng, Jian-Jing Jiang.and Ru-Cheng Xiao, Hai-Fan Xiang "Nonlinear Aerostatic Stability analysis of Jiang Yin Suspension Bridge", Elsevier , *Engineering Structures* 24 (2002) 773–781.
8. Jin Cheng, Ru-cheng Xiao "Probabilistic Free Vibration and Flutter analyses of Suspension Bridges", Elsevier, *Engineering Structures* 27 (2005) 1509–1518.

# Flooding in Computer Network With Passive Clustering

Darshana Mistry

Computer Engineering Dept., Gandhinagar Institue Of Technology,  
Ahmedabad, India  
Darshana.mistry@git.org.in

**Abstract**— An ad hoc network is a fast deployable self configuring wireless network characterized by node mobility, dynamic topology structure, unreliable media and limited power supply. Nodes in an ad hoc network must cooperate and carry out a distributed routing protocol in order to make multi-hop communications possible. On Demand Routing is one of the most popular routing styles in ad hoc networks. In On Demand Routing, "flooding" Is used to find a feasible route from source to destination. The function of flooding is to deliver a packet from one source to every other node in the system. Conventional flooding can be very costly in On Demand networks in terms of network throughput efficiency as well as node energy consumption. The main reason is that the same packet is rebroadcast unnecessarily several times (redundant rebroadcast). Indeed, the penalty of redundant rebroadcast increases when the size of network grows and the density of network increases. In this paper we introduce a novel clustering scheme, call Passive Clustering that can reduce the redundant rebroadcast effect in flooding.

*Keywords*-Flooding, Passive Computing

## I. FLOODING IN COMPUTER NETWORKS

Flooding is a packet dissemination procedure by which every incoming packet at a node is sent out on every outgoing link except the one it arrived on. In a wireless environment, the physical exclusion of the arriving link is impossible. Since the media is broadcast, a single relay of a flooding packet fulfils the task if the broadcasting is successful, i.e., all neighbors receive the packet. Unfortunately, some of the neighbors may not receive the packet due to many reasons including noise, receivers' status, mobility, collision etc. Since every neighbor that has received the packet will rebroadcast it, flooding can generate an infinite number of duplicate packets if there is no control mechanism. One of the mechanisms for prohibiting infinite duplication is tracking flooding packets. Duplicates are detected (from a unique source identifier and a sequence number, for example) by each receiving node and are immediately discarded in order to avoid endless looping. Another control mechanism is Time-to-Live (TTL). A flooding packet carries

a TTL field which represents the maximum hop that the packet can traverse. Upon reception of a flooding packet, the receiving node checks the TTL field and determines whether the packet will be rebroadcasted (after decreasing TTL) or dropped. Path logging in a flooding packet can also be a controlling mechanism. By carrying a list of nodes that a flooding packet has visited, a node can easily avoid looping by examining its ID in the list. If there is a match, the node drops the "returning" packet. In spite of the control mechanisms listed above, flooding generates replicated packet arrivals to each node; namely, one replica for each neighbor. Thus, flooding overhead corresponding to replicated, redundant packets increases with connectivity. Flood search is the capstone of all on-demand rough and multicast protocols. These protocols need to find a path on demand. Since one generally assumes that there is no underlying routing or relative geographical positioning infrastructure that can guide the packet to destination, a path search query must be flooded to the entire network, or at least through a certain section (scope) of it. Once the path search query packet reaches a destination by flooding, the destination can report a path to the source as a reverse path through which the search packet came. Or the destination can report the path to the source with another flooding in case there are asymmetric links. AODV (Ad hoc On-demand Distance Vector routing [1]), for example, uses seeped flooding to find a route. By tagging "Time To Live (TTL)" on each Route-Request flooding packet, a source gradually enlarges flood search diameters. On the other hand, DSR depends on complete flooding to the entire network if a source cannot find a path to destination in a single hop. If the communication patterns are "local", scoped flooding is effective. On the other hand, if destinations typically many hops away, it would be wasteful to run the incremental scoped flooding.

## II. EFFICIENT FLOODING

Generally speaking, flooding in ad hoc networks is used to find a feasible route to a destination or to advertise routing information. If the network is dense, it is not necessary for every node to relay the flood search packet. In fact, it may suffice to use only a subset of nodes as relays. There are many ways to reduce the number of forwarding participants. All of the approaches concern selecting the dominant set, i.e.,

a minimal subset of forwarding nodes which is sufficient to deliver the flooding packet to every other node in the system. There are two basic approaches for selecting the dominant set: without and with a clustering structure. The first approach (no clustering) includes the building of a source tree with the maximal number of leaf nodes and the building of a well covered mesh [6,7]. By excluding leaf nodes from forwarding participation, the method can improve flooding efficiency. To build such source tree, two hop connectivity information is necessary. To collect the required information, at least two complete floorings from a source are necessary. The first flooring (which can be replaced with well-coordinated hello messages) is to learn the one-hop neighbors. The second flooring is to report the direct (one-hop) neighbor lists. By collecting the complete neighbor lists of all of its neighbors, a node can construct the two-hop connectivity, i.e., the list of nodes that are two hops away. From this fist, each node selects the minimum set of one-hop neighbors which cover all the downstream two-hop neighbors. This problem can be reduced to the well-known "set-cover" problem (NP-complete). Starting from a source and applying this procedure recursively one generates the non-leaf nodes of a minimal flooding tree. Span and GAF build their dominant set as a well-covered mesh. Span selects nodes that are potentially on critical paths as coordinators, i.e. members of a dominant set. GAF partitions the region with a grid such that any nodes in neighboring cells can communicate each other; one node per cell is selected to form the dominant set. The complexity of the selection algorithm in this category is dependent on the number of neighbors (except for GAF which requires GPS information instead). In other words, complete neighbor list knowledge is always the assumption. Note that the neighbor-learning procedure is not trivial in ad hoc networks and it involves substantial overhead with high node density and mobility. The second approach is based on a two-hop clustering structure. To illustrate this concept., let us consider the n node example in Figure 1. Let r be a transmission range, and the size of the roaming space be  $((k/\zeta^2)r)^2$  where k is an even number (Figure 1 depicts the case of k = 6 ). There are n nodes in the square, but in the figure we only show the nodes at coordinates  $((a/\zeta^2)r, ((a/\zeta^2)r))$  where either a or b is an integer smaller than k. This "selection" of nodes is known as "two hop clustering.", ie, any two nodes in a cluster are separated by at most two hops. The nodes at the center of the circles are "cluster heads" and the light-shaded nodes in between are "gateways." Clearly, such nodes represent a connected set. They are in fact the dominant set required to forward the flood packets. Without the cluster overlay shown in Figure 1, each flood packet is relayed exactly n-1 times, as each node must rebroadcast the packet once. On the other hand,

$$(k-1)*k/2+k/2(k/2-1)=(k*(3*k-4))/4$$

broadcasts suffice if only cluster heads and gateways forward the packet. Note that in the cluster restricted forwarding, ALL nodes still receive the flood packet. The flooding reduction is thus  $((k*(3*k-4))/4)/(n-1)$  In case of n = 100

and k=6, the number of broadcasts required in the cluster is 21 instead of 99. In other words, 78.8% of transmissions can be saved. This is not even a very dense network (each node has about 12 neighbors). As we increase the number of nodes in the system (and therefore the density), the clustering structure and thus the broadcast remains the same. As a result, the saving increases with the node density,



Figure 1. Selective Gateway Flooding Scenario

### III. CLUSTERING IN AD HOC NETWORKS

In the previous section we showed that clustering is one of the key approaches to flood overhead reduction. In this section, we elaborate on this important concept. Clustering in wireless ad hoc networks has been investigated in the past in order to enhance network manageability, channel efficiency, and energy economy. Moreover, clustering is indispensable for hierarchical routing or multicasting[2]. However, the clustering schemes proposed so far in the literature are "active". They require a constant refresh rate of cluster-dependent information, and therefore introduce significant background control overhead even if there is no data to send in the network. In some applications, for example, covert military operations and sensor networks, this periodic control traffic is highly undesirable. The penalty introduced by the control traffic (eg, exposure to enemy interception, power consumption, etc) may offset the benefits offered by clustering. Clustering in ad hoc networks can be informally defined as *grouping of nodes into a manageable set*. Many prior research efforts carried out clustering in different ways. Such efforts started with the DARPA packet-radio network . As a result, the network was dynamically organized into clusters similar to the cluster structure shown in fig. 1.

Several clustering mechanisms have been proposed in the literature The schemes reported in all lead to similar structures (overlapping two-hop clusters with cluster heads). The schemes in partition the network into disjoint sets of clusters. All of these clustering mechanisms assume prior knowledge of the full neighbor list, or they periodically monitor neighbor information by exchanging explicit control

packets. This topology learning overhead is significant if the number of neighbors is large and the topology is dynamic. None of these schemes will work properly with only partial neighbor information. An important subclass implements two-hop clustering. Two-hop clustering requires that every node in a cluster be reached from another node in the same cluster with at most two hops. Two-hop cluster is a natural clustering structure in ad hoc networks. It only requires direct neighbor information and is easy to construct. The cluster structure in Figure 1 is an example of a two-hop cluster structure. Two-hop clustering has the following properties:

- There is a cluster head at the center of a cluster, and the cluster head can communicate with any node in the cluster with a single hop.
- No cluster heads are directly linked.
- Any two nodes in a cluster are at most two hops away. Two-hop clustering ends up with a structure similar to the cellular system. There are cluster heads at the center of each cluster (a useful by-product). Nodes belonging to more than one cluster are gateways. The rest of the nodes are ordinary nodes.

#### *A.Limitation of Existing (Active) Clustering Scheme*

Most clustering algorithms in the past have been studied via simulation and have used the complete neighborhood information. Unlike the simulation environment, accurate global information regarding node locations and adjacency relations is hard to collect in an actual wireless ad hoc network implementation, especially when the node density is high. The major difficulties stem from unreliable and limited link capacity, and from node mobility. Node locations and neighborhood information are key for clustering; unfortunately, they do vary in time. Without the help of a special node – say "oracle" which can listen or talk to all the nodes at the same time - adjacency (neighborhood) information can only be collected by exchanging beacons or hello messages. In this neighbor learning process, no mobility is generally assumed. To ensure the correct collection of neighborhood information, existing clustering solutions rely on periodic broadcast of the neighbor list. In the period of neighbor learning and initial clustering, it is essential that there is no mobility for proper convergence. The quasi-stationary assumption must hold during the adjacency information collecting period, initial clustering, and the re-clustering or clustering maintenance period. If there is motion, we may have to deal with stale neighborhood information during the neighbor learning period. Moreover, mobility causes adjacency relations to change, which in turn may trigger re-clustering throughout the network. Other drawbacks including isolation (structural disconnection), etc., are listed and explained in.

## IV. PASSIVE CLUSTERING

In this section, we introduce a new cluster formation protocol that is free from the periodic overhead and other limitations discussed in the previous section. This novel approach not only overcomes many limitations of existing clustering mechanisms, but also improves performance and yields new features. Here, we present the concept of passive clustering and illustrate its operation by example. The proof of its correct operation and the detailed description can be found in.

### *A.Protocol Overview*

Passive Clustering is a cluster formation protocol that does not use dedicated protocol-specific control packets or signals. Conventional clustering algorithms[2], as earlier discussed, require all of the participating network nodes to advertise cluster dependent information repeatedly. Moreover, most of the existing clustering schemes require the execution of a separate clustering phase prior to any network layer activity (e.g., routing). With passive clustering, we avoid all the above limitations. By monitoring user data packets that piggyback some predefined cluster information, we can build impromptu "soft state" clusters for mobile wireless networks. Thus, the cluster infrastructure can be constructed as a by-product of user traffic, without any dependency on the routing protocol, for example. In passive clustering, each node collects neighbor information from the MAC sender address carried by the incoming packets, and can construct clusters even without collecting the complete neighbor list. This is an innovative approach to clustering which virtually eliminates major cluster overheads - the time latency for initial clustering construction as well as the communication overhead for neighbor information exchanges. Instead of using protocol specific signals or packets, cluster status information (2 bits for four states: Initial, Cluster head, Gateway, and Ordinary-node states) of a sender is stamped in a reserved field in the packet header. Sender ID (another key piece of information for clustering) is carried by all the existing MAC protocols and can be retrieved from the MAC header. Since in flooding the MAC packets are transmitted in broadcast (instead of unicast mode, every node receives and reads the packets (in a promiscuous way), and thus participates in passive clustering. Note: you cannot perform flooding at the MAC layer because you need to detect duplicates (reading, for example, flood originator ID number which is stored in the packet, not MAC, header). Since passive clustering relies on flooding packets, it may as well be done at the packet layer. Surprisingly, simulation results show that passive clustering can form better clusters than conventional clustering schemes based on eight (i.e., ID, degree, etc.) information. This is because passive clustering (as used in the support of ad hoc muting schemes) uses network traffic that emanates from sources (i.e., the source in search of a path). If a cluster structure is constructed by a flooding from a single source, the resulting structure is completely immune from logical isolation and lack of connectivity. Clustering stability and fast convergence time are other important properties required of clustering

algorithms. To improve clustering stability and speed up convergence, and most importantly, to avoid the "stationary" requirement during the neighbor-learning and clustering phase, we developed a new cluster head election rule which does not require any weight information. We call this rule "first declaration wins." With the first declaration wins rule, a node which first claims to be the cluster head remains the cluster head and "rules" the rest of nodes in its clustered area (radio coverage). There is no waiting period (to make sure all the neighbors have been checked) unlike in all the weight-driven clustering mechanisms.

### B. Operational Description

When a node is ready to become a cluster head and has packets to send, it declares that it is a cluster head by stamping its clustering state claim in the packets. Since passive clustering does not support explicit control packets or signals of its own, a cluster head-ready node must postpone its claim until it has outgoing "application" packet level traffic, for example, flood search packet traffic. After a successful transmission from an aspiring cluster head, every node within radio coverage learns the presence of the cluster head by monitoring the "cluster" state of the received packets. At this point, the neighbors of the cluster head record the cluster head information (cluster head ID and the most recent transaction time-timestamp) and change their clustering states as discussed below. The readiness of being a cluster head is determined by network activities as well as by the node's clustering state. After a period of inactivity (i.e., no incoming or outgoing traffic for longer than the cluster timeout period), all the nodes revert to the INITIAL state. Only nodes in INITIAL state can be cluster head candidates - in other words, two hop is the minimum distance between any two cluster heads since all neighbors of a declared cluster head exit the INITIAL state. After a cluster head successfully asserts its state, it functions as a cluster head. Cluster heads collect neighbor information by monitoring the network traffic. They are responsible for relaying intra cluster packets. A node that hears more than one cluster head becomes a GATEWAY. It reverts to ORDINARY node if it does not hear from more than one cluster head for a given period. In the next section we will describe a slightly modified procedure (selective gateway) in which a part of gateways in this definition also reverts to ordinary node upon hearing a certain number of other gateways. A node that is neither a cluster head nor a gateway is an ordinary node. The ordinary node does not forward flooding packets. It is precisely this forward-suppression mechanism that reduces flood overhead. Gateway nodes and cluster heads, on the other hand, will keep forwarding the flood packets. Because of the passive nature of the collection mechanism, neighbor information is kept in soft state and is possibly incomplete. Note here again that complete neighbor information is no longer necessary to form the structure. By using timestamps for neighbor information, we preserve the freshness of the information. Ordinary nodes and gateways keep a list of their cluster head(s) in soft states. The time, out period has to be carefully chosen based on node mobility and communication pattern.

Non-cluster head nodes can collect their own cluster head(s) information in a passive way. If a received packet is from a cluster head (after checking the status information in the packet), non-cluster head nodes compare the sender ID of the packet with their own cluster head list and add or refresh accordingly.

## V. SELECTIVE GATEWAY PASSIVE CLUSTERING

In typical examples implementing the above basic scheme, one quickly discovers that the number of gateways is quite significant and is typically larger than that of ordinary nodes. Clearly, there is quite a bit of redundancy here, and not all of the gateways have to relay the flooding packets. It is mandatory to reduce the number of gateways in order to achieve efficient flood search packet suppression. Careful gateway selection is the natural solution to improving flooding efficiency. To select the strictly minimal set of gateways, we would need to collect the cluster head list for each gateway, and then choose one gateway for each pair of cluster heads. This is another set-cover problem and introduces extra communication and computation overhead since the procedure requires cluster head list exchanges between gateways. In order to avoid the communication and computation complexity, we introduce a heuristic solution to this problem in the following section.

### A. Gateway Selective Heuristic

Instead of selecting a single gateway between adjacent cluster heads (two-hops away), we developed a heuristic algorithm that enables a limited number of gateways, and at the same time, preserves adequate connectivity within the resulting cluster structure. The selection algorithm provides many advantages including on-the-fly flooding improvement, redundant connectivity, and higher overall flooding efficiency. The heuristic also allows "distributed gateway" implementations. Every non-cluster head node monitors and keeps track of the number of cluster heads (NC) and the number of gateways (NG) within range. Whenever a non-cluster head node hears a packet from a cluster head or a gateway, the node becomes a gateway if  $\alpha \cdot NC + fl > NG$ , where  $\alpha$  is a coefficient properly chosen based on the desired degree of gateway redundancy ( $\alpha \geq 0$ ) and  $fl$  is a gateway redundancy factor ( $fl \geq 0$ ). Otherwise, the non-cluster head node becomes an ordinary node. The larger the number of cluster heads that a node can hear, the higher the chance to become a gateway. By manipulating  $\alpha$ ,  $fl$ , we can control the number of gateways in the system. The larger the number of gateways, the lower the gain in forwarding overhead reduction. On the other hand, if there are too few gateways, connectivity may be impaired leading to a poor network performance. In this paper,  $\alpha$  and  $fl$  are global system parameters and are both set to 1. The values of  $\alpha$  and  $fl$  should be chosen based on considerations including channel quality, noise level, as well as traffic pattern. For that reason,  $\alpha$  and  $fl$  can be local parameters, i.e., they can be locally adjusted to provide better adaptability and flexibility. In dense networks where packet collisions abound, higher values of those

parameters lead to more gateways and better network performance by distributing network traffic over more gateways. Conversely, in low density we suggest to keep the parameters low to discourage multiple gateway creation. By introducing these heuristic, passive clustering strikes a good balance between cluster heads and gateways and retains only a handful of forwarding nodes for flood search no matter how high the node density is. The gateway selection procedure is fully distributed, and requests only local information. No cluster head fist exchange is required.

### *B. Flooding Improvement on Fly*

Let us consider the example of single-source flooding from a cold start. Every node is in the Initial state, and a source broadcasts a Route Request packet. The immediate neighbors of the source receive the packet, and change their state to Cluster head-Ready. When one of the neighbors is ready to forward the packet, it changes its state to Cluster head, and broadcasts the Route Request packet with the Cluster head state assertion. This time, all the nodes including the source that receive the relayed Route Request packet from that newly proclaimed cluster head are eligible to become gateways since they have heard from one cluster head, and from no gateways (for simplicity, in this case we assume  $a = 1$  and  $p = 0$ .) Now, one of the gateways except the source may relay the flood search packet. This relay does not switch any gateways back to ordinary nodes because they still have the number of cluster heads ( $= 1$ ) which is equal to or smaller than the number of gateways (0 or 1). Let us say that a second gateway within range of the first declared gateway relays the flooding packet. Thereafter, none of

nodes in the intersection area of those two gateways can become a gateway - they turn into ordinary nodes after they receive the second flooding packet - their head count for cluster head equals 1 but they have already 2 gateways. One may notice that there is a chance of critical path loss with these heuristics. However, extensive simulation experiments have shown that the risk of flood delivery failure to certain areas of the network is negligible, even with moderate node density, if the coefficient  $a$  and the redundancy factor  $p$  are properly chosen. With additional assistance from the routing protocol, we can completely eliminate such "block out" areas.

### *C. Properties of Passive Cluster Solution*

It is appropriate at this point to compare and contrast passive clustering with traditional, lowest ID active clustering. We have already discussed the impact of the background updating procedure and the neighbor list broadcast requirements on the control traffic overhead caused by active clustering. Here we focus on the structure of the solutions. Typically, one finds that the two solutions are comparable (in terms of number and layout of clusters). Major differences are: (a) the fact that active clustering is carried out independently, in the background and in parallel across all nodes in the network, while passive clustering is "on-demand" and is initiated by a single "source", namely the first source that needs to send data. Thus, active clustering tends to lead to disconnected islands (which require the

"distributed gateway" feature- ie gateway to gateway links to reestablish connectivity). Passive clustering does not suffer from this problem (albeit it can also be extended to support distributed gateways) (b) the fact that passive clustering features the "selective gateway" provision. Popular active clustering schemes do not include such feature (c) the lowest ID feature tends to make the active clustering more sensitive to mobility - the cluster head can be more easily challenged by newcomers with lower ID Another important issue is the suitability of Passive Clustering for Low Energy operations, as in battlefield scenarios or sensor network applications. Repeated selection of the same subset of clusters and gateways can be detrimental to low power operation in that it creates uneven energy consumption. In this respect, passive clustering is beneficial. In fact it favors even distribution since at each new cluster formation round (caused by the arrival of a new user data session, say), new clusters and gateways are selected as the source changes and/or, even in the case of same source, the random timers cause different cluster-heads and gateways to assert their role first. In the case of "permanent" traffic pattern where the cluster structure tends to persist, a possible remedy is to associate the cluster-head and gateway status with a minimum energy level requirement. When energy drops below this threshold, the role is given up triggering a new election.

## VI. CONCLUSION

A passive new clustering algorithm for efficient flooding in ad hoc networks. For efficient flooding, we propose to superimpose an on demand cluster structure which can be quickly deployed in the "unstructured" ad hoc network, and let only non-ordinary nodes (cluster heads, gateways, "initial state" nodes) participate in the flooding process. Due to its passive nature, passive clustering does not introduce any control packets dedicated to the protocol. In other words, it is "control overhead free". Thus, it can reduce the cost of flood search significantly without producing any line overhead. Even better, there is no preparation time or overhead for selecting dominant sets. As the results, the number of flooding relays can be significantly reduced even during the first flooding. This is the unique feature and strongest advantage of the proposed mechanism. It is especially useful for ad hoc networks with high mobility. The gateway selection scheme is density-adaptive. Its efficiency increases linearly with the number of neighbors, ie, with node density. Beside assisting with flood reduction, the clustering structure offers several other side benefits. In particular, it can be beneficial to routing scalability, reliability and QoS support. Passive clustering is a self-sufficient clustering scheme. The protocol collects all the

necessary information itself and does not require costly information like global topology knowledge from the lower layer. The resulting cluster structure is superior to any existing clustering algorithm in terms of stability, mobility robustness and connectivity. Passive clustering can build the cluster structure with partial neighbor information which, in most cases, is the only possible information available in an ad hoc network.

## REFERENCES

- [1] Das S.R, Perkins C.E. and Royar E.M. "Performance comparance of Two On-demand Routing Protocols for Ad hoc Networks, In processing of IEE INFOCOM 2000, Tel Aviv, Isreal, March 200.
- [2] T. J. Kwon, M.Geria, "Efficient flooding with passive clustering(PC) in Ad hoc networks",ACM SIGCOMM,44-56.
- [3] K. Obraczka, K.Vishvanath, "Flooding for Reliable Multicast in Multi-Hop Ad hoc networks", Wireless networks,627-634, Kluwer Academic Publishers, 2001
- [4] J. Li, P.Mohapatra, "PANDA: A novel mechanisam for flooding based route discovery in ad hoc networks",Wireless networks (2006) 771-787.
- [5] V.Shurbanov, J.Redi, "Energy efficient flooding in Mobile Ad hoc networks"
- [6] Chen, B., Jamieson, K., Balakrishnan, H. and Morris, R., Span: An energy-efficient coordination algorithm for topology maintenance in Ad Hoc wireless *networks*, *In* Proceedings of ACM/IEEE MOBICOM 2001, Rome, Italy, 2001.
- [7] Xu, Y., Heidernann, J. and Estrin, D., *Geographyinformaed* Energy Conservation for Ad Hoc Routing..In Proceedings of ACM/rEi~ MOBICOM2001,



# ANN BASED INTELLIGENT CONTROLLERS FOR AN INDIRECT VECTOR CONTROLLED THREE-PHASE INDUCTION MOTOR

Ami Patel<sup>1</sup> \* Tejendra Pate<sup>2</sup>

1. Assistant Professor, MGITER, Navsari

2. P.G. Student SVNIT, Surat

43/B Alka Co. op. Hsg. Society, Chhapra road, Navsari,

Pin code: 396445, (M): 1) 9724326517

[ami\\_engg86@yahoo.com](mailto:ami_engg86@yahoo.com)

[ami.mgiter@gmail.com](mailto:ami.mgiter@gmail.com)

**Abstract:** -Artificial Intelligent methods such as Fuzzy Logic control and Neural Network control have found high applications in most of the nonlinear systems like the electric motor drives. These Intelligent controllers can be used for any system without requirement of the system mathematical model unlike that of the conventional electrical drive control, which requires the mathematical model. Due to the usage of the FLC and Neural Network control concept, the efficiency, reliability & performance of the AC drives increases. This paper presents a Fuzzy logic and Neural network based speed controller and its design for vector controlled induction motor drive. These controllers have been implemented on 3 phase, 415 V, 5 HP squirrel cage induction motor. Test response for the developed schemes are given and discussed in detail.

**Key words:** Induction motor, Vector control, Fuzzy logic, Neural Network

## 1. Introduction:

Induction motors are widely used in industries due to its robust construction and low maintenance. Separately excited dc drives are simpler in control because independent control of flux and torque can be brought about. In contrast, induction motors involve a coordinated control of stator current magnitude and the phase, making it a complex control. The stator flux linkages can be resolved along any frame of reference. This requires the position of the flux linkages at every instant. Then the control of the ac machine is very similar to that of separately excited dc motor. Since this control involves field coordinates it is also called field oriented control. The requirement of the phase angle of the flux linkages in the control process gives the name vector control. [1]

Along with industrial progress high performance drives are essential. Recent advances in semiconductors, converters and new control techniques have great role in this progress. Usually classical control requires accurate mathematical model of the system and also its performance decreases for nonlinear system such as drives. Recently by adapting non linear speed control techniques the dynamic performance of electric drives can be improved.

This paper proposes implementation of fuzzy logic and Neural Network control scheme applied to model of Induction motor. Both the controllers are developed on MATLAB environment. The performance of Fuzzy logic controller and Neural Network controller is compared with that of classical controller in terms of rise time and steady state error. The developed control scheme was verified by simulation and the results obtained demonstrate the effectiveness of Intelligent controllers.

## 2. Indirect Vector control:

Indirect vector control method is very popular in industrial applications. The block diagram of VCIMD is shown in fig.1. The motor current is decomposed in two components  $i_{ds}$  and  $i_{qs}$ , direct and indirect axis current with respect to synchronously rotating reference frame. These current are responsible for producing flux and torque respectively. Here unit vector signals are generated in feed forward manner. This method uses indirect procedure to ensure presence of rotor flux in the direct axis. With the help of an intelligent controller, the speed error is converted into a torque controlling current component  $i_{qs}$ , of the stator current. This current component is used to regulate the torque along with the slip speed. [1]



The following equations are necessary to implement vector control scheme.



### 3. Fuzzy Logic speed controller Principle and Design:

Basic structure of the fuzzy logic controller to control the speed of the induction motor consists of 4 important stages: Fuzzification, Knowledge Base, Decision-making unit and the Defuzzification. [3]



The design of fuzzy logic controller start with defining input/output variables of controller. In this case first input variable is speed error  $e(k)$  and second is the change in speed error  $_{e}(k)$ . The output variable of the FLC is the change in the torque.

#### 3.1 Fuzzification:

In this stage the crisp variables  $e(k)$  and  $_{e}(k)$  are converted into fuzzy variables which can be identified by membership function. The fuzzification maps the error and change in error to linguistic labels of fuzzy sets. The proposed controller uses following linguistic labels:

NB (Negative Big), NM (Negative medium), NS (Negative small), NVS (Negative very small), Z(Zero), PVS (Positive Very Small), PM(Positive Medium), PB(Positive Big).

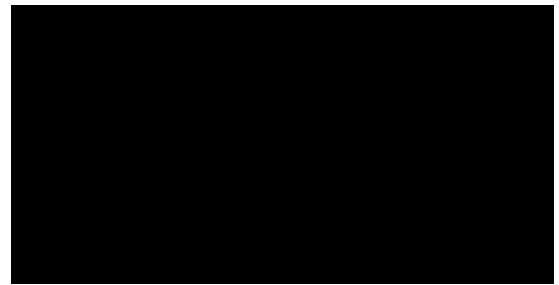

#### 3.2 Knowledge Base and Decision making Unit:

Knowledge base involves defining the rules represented as IF-THEN rules statements which govern relationship between inputs and output variables in terms of membership functions. In this stage the input variables are processed by inference engine that executes 7x7 rules represented in rule base using fuzzy operator (AND,OR). The mapping of the fuzzy inputs into the required output is derived with the help of a rule base as given in following Table.

Table: 1 Rules of Fuzzy Logic Controller



Considering the first rule, it can be interpreted as: IF speed error is NB and rate of change of speed error NB, THEN the output will be NB.

#### 3.3 Defuzzification:

The output of the decision-making unit is given as input to the de-fuzzification unit and the linguistic format of the signal is converted back into the numeric form of data. In this paper, the center of gravity (COA) or centroids method is used to calculate the final fuzzy value  $_{T}(k)$ . This  $_{T}(k)$  value is used to calculate  $i_{qs}$ , which in turn used to command the induction motor via 2 -3 block.

### 4. Neural Network Controller:

The ANN is an Artificial Intelligent technique which is machine like human brain with properties such as learning capability and generalization. It is a system of interconnecting neurons in a network which work together to form the output function. Neuron is a fundamental processing component of a neural network.[5] The performance of ANN relies on member neurons of network collectively. So that it can still perform its overall function even if some of the neurons are not functioning. Thus, they are very robust to error failure. It required a lot of training to understand the model of the plant. To approximate complicated nonlinear functions is the basic property of ANN. [6]



Here, neural network is used to produce torque producing component of current iqs.

The back propagation training algorithm is used for this network. The following matlab simulation program is developed for this purpose, which train the network using the back propagation training method.[8]

Code:

```
net=newff(minmax(ip11),[2,1],{'tansig','purelin'},'traingd');
net = init(net)
net.trainParam.show =50;
net.trainParam.lr = 0.1;
net.trainParam.epochs =5000;
net.trainParam.goal = 0.001;
[net,tr]=train(net,ip11,op11);
a = sim(net,ip11);
```

### 5. Results and discussion:

Here fuzzy Logic controller and Neural Network controllers are developed. Both of these are constructed into MATLAB/SIMULINK environment. Simulation tests were carried out on the PI controller, FL controller and Neural Network controller. Results are compared response.

Figure 6 show the comparison of speed response of PI, FLC and Neural Network controllers at no load. Rise time of fuzzy logic controller is found better compare to conventional PI controller. Rise time of neural network controller is less than that of fuzzy and PI controller. Both fuzzy and neural controller does not find any overshoot. Steady state error is within limit for both fuzzy and neural network controller. Figure 7 (a), Fuzzy logic controller and Neural network controller respectively.

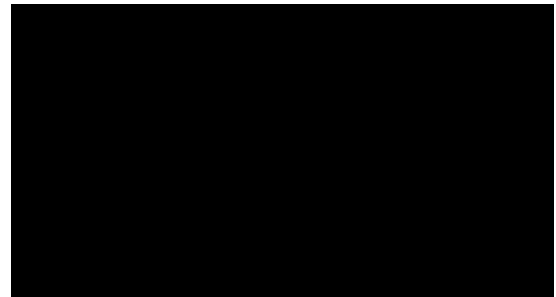

Fig.7 Stator current comparison at no load

### 6. Conclusion:

This paper introduces indirect vector control of induction motor using intelligent techniques. It successfully demonstrates the application of fuzzy logic and neural network for vector controlled induction motor drive. Time response of PI controller is compared with fuzzy logic controller and neural network controller. Performance of Neural Network controller is better in terms of rise time. There is no overshoot in both fuzzy controller and Neural network controller. Also steady state error is acceptable for both the controller. Here the performance and reliability of induction motor is found better.

## 7. References:

- [1]. Bose B.K., "Modern Power Electronics and AC Drives", Prentice Hall
- [2]. Sanjiv Kumar, Bhim singh, J.K.chatterjee, "Fuzzy Logic based speed controller for vector controlled cage induction motor drive "IEEE 1998
- [3]. M. Zerikat, and S. Chekroun, "Design and Implementation of a Hybrid Fuzzy Controller for a High-Performance Induction Motor"
- [4]. Norman Mariun, Samsul Bahari Mohd Noor, Jasronita Jasni, Omar S. Bennanes  
"A Fuzzy logic based controller for vector controlled three-phase Induction motor".IEEE,2004
- [5]. K.M.Hasan, Li Zhang , B.Singh, "Neural Network Control of Induction Motor Drives for Energy Efficiency and High Dynamic Performance"
- [6]. A. K. Sharma, R. A. Gupta, and Laxmi Srivastava," Implementation of neural network in Energy saving of induction motor drives with indirect vector"
- [7]. M. Godoy Simces, Bimal K. Bose, "Neural Network Based Estimation of Feedback Signals for a Vector Controlled Induction Motor Drive"
- [8]. [www.mathwork.com](http://www.mathwork.com)

# Comparative Study of Web Services and Software oriented Architecture for Mobile Augmented Reality System

.....DR. Bijendra Agrawal<sup>1</sup> , Jatin Shah<sup>2</sup> ,  
1.Principal, VKMS College, "  
2.MCA, Research Scholar, .....,  
.....Vadu  
[jatinshah79mca@gmail.com](mailto:jatinshah79mca@gmail.com) "  
[bijendra\\_agrawal@yahoo.com](mailto:bijendra_agrawal@yahoo.com)

**Abstract:-SOA and Web Services are two buzzwords in the software industry now a days. Most of the people are confused about, What they are?. And they don't know the difference, they take them as synonyms. In this paper, we clearly show the difference between these two.Also the architecture of the Web Services in normal situation and architecture for web services based on SOA in terms of Mobile Augmented Reality System.**

## Introduction :

Einstein made that famous statement many decades ago, and it's still relevant today for building superior software systems. Unfortunately, as anyone who has been in the IT industry for long can point out, far too many software systems have failed Einstein's test. Some are made too simple to carry out the duties they are supposed to perform. Others are made too complex, and the costs of building and maintaining them have rocketed, not to mention the nearly impossible tasks of integrating different systems together. It seems that reaching the right level of simplicity is more like a dream than reality.

## Loose Coupling:

We don't have to look far to find the problems. As we build more and more software systems, we see similar situations and patterns appearing. Naturally, we want to reuse the functionality of existing systems rather than building them from scratch. A real dependency is a state of affairs in which one system depends on the functionality provided by another. If the world only contained real dependencies, Einstein's test would have been satisfied long time ago. The problem is that we also create artificial dependencies along with real dependencies.

If you travel overseas on business, you know that you must bring power adapters along with you or your life will be miserable. The real dependency is that you need power; the artificial dependency is that your plug must fit into the local outlet. Looking at all the varying sizes and shapes of those plugs from different countries, you would notice that some of them are small and compact while many others are big and bulky.

The lesson here is that we cannot remove artificial dependencies, but we can reduce them. If the artificial dependencies among systems have been reduced, ideally, to their minimum, we have achieved loose coupling. In that sense, Einstein was just talking about was loose coupling. We might rework his famous principle thus: "Artificial dependencies should be reduced to the minimum but real dependencies should not be altered."

## SOA Defined and Explained

Now we are able to define a Service Oriented Architecture (SOA). SOA is an architectural style whose goal is to achieve loose coupling among interacting software agents. A service is a unit of work done by a service provider to achieve desired end results for a service consumer. Both provider and consumer are roles played by software agents on behalf of their owners.

This sounds a bit too abstract, but SOA is actually everywhere. Let's look at an example of SOA which is likely to be found in your living room. Take a CD for instance. If you want to play it, you put your CD into a CD player and the player plays it for you. The CD player offers a CD playing service. Which is nice because you can replace one CD player with another. You can play the same CD on a portable player or on your expensive stereo. They both offer the same CD playing service, but the quality of service is different.

The idea of SOA departs significantly from that of object oriented programming, which strongly suggests that you should bind data and its processing together. So, in object oriented programming style, every CD would come with its own player and they are not supposed to be separated. This sounds odd, but it's the way we have built many software systems.

The results of a service are usually the change of state for the consumer but can also be a change of state for the provider or for both. After listening to the music played by your CD player, your mood has changed, say, from "depressed" to "happy". If you want an example that involves the change of states for both, dining out in a restaurant is a good one.

The reason that we want someone else to do the work for us is that they are experts. Consuming a service is usually cheaper and more effective than doing the work ourselves. Most of us are smart enough to realize that we are not smart enough to be expert in everything. The same rule applies to building software systems. We call it "separation of concerns", and it is regarded as a principle of software engineering.

How does SOA achieve loose coupling among interacting software agents? It does so by employing two architectural constraints:

1. A small set of simple and ubiquitous interfaces to all participating software agents. Only generic semantics are encoded at the interfaces. The interfaces should be universally available for all providers and consumers.
2. Descriptive messages constrained by an extensible schema delivered through the interfaces. No, or only minimal, system behavior is prescribed by messages. A schema limits the vocabulary and structure of messages. An extensible schema allows new versions of services to be introduced without breaking existing services.

As illustrated in the power adapter example, interfacing is fundamentally important. If interfaces do not work, systems do not work. Interfacing is also expensive and error-prone for distributed applications. An interface needs to prescribe system behavior, and this is very difficult to implement correctly across different platforms and languages. Remote interfaces are also the slowest part of most distributed applications. Instead of building new interfaces for each application, it makes sense to reuse a few generic ones for all applications.

Since we have only a few generic interfaces available, we must express application-specific semantics in messages. We can send any kind of message over our interfaces, but there are a few rules to follow before we can say that an architecture is service oriented.

First, the messages must be descriptive, rather than instructive, because the service provider is responsible for solving the problem. This is like going to a restaurant: you tell your waiter what you would like to order and your preferences but you don't tell their cook how to cook your dish step by step.

Second, service providers will be unable to understand your request if your messages are not written in a format, structure, and vocabulary that is understood by all parties. Limiting the vocabulary and structure of messages is a necessity for any efficient communication. The more restricted a message is, the easier it is to understand the message, although it comes at the expense of reduced extensibility.

Third, extensibility is vitally important. It is not difficult to understand why. The world is an ever-changing place and so is any environment in which a software system lives. Those changes demand corresponding changes in the software system, service consumers, providers, and the messages they exchange. If messages are not extensible, consumers and providers will be locked into one particular version of a service. Despite the importance of extensibility, it has been traditionally overlooked. At best, it was regarded simply as a good practice rather than something fundamental. Restriction and extensibility are deeply entwined. You need both, and

increasing one comes at the expense of reducing the other. The trick is to have a right balance.

Fourth, an SOA must have a mechanism that enables a consumer to discover a service provider under the context of a service sought by the consumer. The mechanism can be really flexible, and it does not have to be a centralized registry.

## Purpose of the Web Service Architecture

Web services provide a standard means of interoperating between different software applications, running on a variety of platforms and/or frameworks. This document (WSA) is intended to provide a common definition of a Web service, and define its place within a larger Web services framework to guide the community. The WSA provides a conceptual model and a context for understanding Web services and the relationships between the components of this model.

The architecture does not attempt to specify how Web services are implemented, and imposes no restriction on how Web services might be combined. The WSA describes both the minimal characteristics that are common to all Web services, and a number of characteristics that are needed by many, but not all, Web services.

The Web services architecture is an *interoperability* architecture: it identifies those global elements of the global Web services network that are required in order to ensure interoperability between Web services.

## What is a Web service?

A Web service is a software system designed to support interoperable machine-to-machine interaction over a network. It has an interface described in a machine-processable format (specifically WSDL). Other systems interact with the Web service in a manner prescribed by its description using SOAP messages, typically conveyed using HTTP with an XML serialization in conjunction with other Web-related standards.

## Agents and Services

A Web service is an abstract notion that must be implemented by a concrete agent. The agent is the concrete piece of software or hardware that sends and receives messages, while the service is the resource characterized by the abstract set of functionality that is provided. To illustrate this distinction, you might implement a particular Web service using one agent one day (perhaps written in one programming language), and a different agent the next day (perhaps written in a different programming language) with the same functionality. Although the agent may have changed, the Web service remains the same.

## Requesters and Providers

The purpose of a Web service is to provide some functionality on behalf of its owner -- a person or organization, such as a business or an individual. The *provider entity* is the person or organization that provides an appropriate agent to implement a particular service.

A *requester entity* is a person or organization that wishes to make use of a provider entity's Web service. It will use a *requester agent* to exchange messages with the provider entity's *provider agent*.

### Service Description

The mechanics of the message exchange are documented in a Web service description (WSD). The WSD is a machine-processable specification of the Web service's interface, written in WSDL. It defines the message formats, data types, transport protocols, and transport serialization formats that should be used between the requester agent and the provider agent. It also specifies one or more network locations at which a provider agent can be invoked, and may provide some information about the message exchange pattern that is expected. In essence, the service description represents an agreement governing the mechanics of interacting with that service.

### Semantics

The semantics of a Web service is the shared expectation about the behavior of the service, in particular in response to messages that are sent to it. In effect, this is the "contract" between the requester entity and the provider entity regarding the purpose and consequences of the interaction. Although this contract represents the overall agreement between the requester entity and the provider entity on how and why their respective agents will interact, it is not necessarily written or explicitly negotiated. It may be explicit or implicit, oral or written, machine processable or human oriented, and it may be a legal agreement or an informal (non-legal) agreement. While the service description represents a contract governing the mechanics of interacting with a particular service, the semantics represents a contract governing the meaning and purpose of that interaction. The dividing line between these two is not necessarily rigid. As more semantically rich languages are used to describe the mechanics of the interaction, more of the essential information may migrate from the informal semantics to the service description. As this migration occurs, more of the work required to achieve successful interaction can be automated.

There are many ways that a requester entity might engage and use a Web service. In general, the following broad steps are required, (1) the requester and provider entities become known to each other (or at least one becomes know to the other); (2) the requester and provider entities somehow agree on the service description and semantics that will govern the interaction between the requester and provider agents; (3) the service description and semantics are realized by the requester and provider agents; and (4) the requester and provider agents exchange messages, thus performing some task on behalf of the requester and provider entities. (I.e., the exchange of messages with the provider agent represents the concrete manifestation of interacting with the provider entity's Web service.) Some of these steps may be automated, others may be performed manually.

### The Architectural Models

This architecture has four models, illustrated in. Each model in is labeled with what may be viewed as the key concept of that model.

The four models are:

1) The Message Oriented Model focuses on messages, message structure, message transport and so on — without particular reference as to the reasons for the messages, nor to their significance.



The essence of the message model revolves around a few key concepts illustrated above: the agent that sends and receives messages, the structure of the message in terms of message headers and bodies and the mechanisms used to deliver messages. Of course, there are additional details to consider:

the role of policies and how they govern the message level model. The abridged diagram shows the key concepts; the detailed diagram expands on this to include many more concepts and relationships.

2) The Service Oriented Model focuses on aspects of service, action and so on. While clearly, in any distributed system, services cannot be adequately realized without some means of messaging, the converse is not the case: messages do not need to relate to services.

The Service Oriented Model is the most complex of all the models in the architecture. However, it too revolves around a few key ideas. A service is realized by an agent and used by another agent. Services are mediated by means of the messages exchanged between requester agents and provider agents.

A very important aspect of services is their relationship to the real world: services are mostly deployed to offer functionality in the real world. We model this by elaborating on the concept of a service's owner — which, whether it is a person or an organization, has a real world responsibility for the service.

Finally, the Service Oriented Model makes use of meta-data, which, as described in **Service Oriented Architecture**, is a key property of Service Oriented Architectures. This meta-data is used to document many aspects of services: from the details of the interface and transport binding to the semantics of the service and what policy restrictions there may be on the service. Providing rich descriptions is key to successful deployment and use of services across the Internet.

3) The Resource Oriented Model focuses on resources that exist and have owners.

The resource model is adopted from the Web Architecture concept of resource. We expand on this to incorporate the relationships between resources and owners.

4) The Policy Model focuses on constraints on the behavior of agents and services. We generalize this to resources since policies can apply equally to documents (such as descriptions of services) as well as active computational resources.

Policies are about resources. They are applied to agents that may attempt to access those resources, and are put in place, or established, by people who have responsibility for the resource.

Policies may be enacted to represent security concerns, quality of service concerns, management concerns and application concerns.

## **Conclusion:**

The web services approach is based on a maturing set of standards that are widely accepted and used. This widespread acceptance makes it possible for clients and services to communicate and understand each other across a wide variety of platforms and across language boundaries. Design architecture for mobile augmented Reality System SOA based Web Services played vital role due to the limitation of mobile device.

## **References:**

<http://www.w3.org/TR/2004/NOTE-ws-arch-20040211/>

<http://www.w3.org/TR/ws-arch/>

<http://www.w3.org/TR/2003/WD-ws-arch-20030808/>

[www.service-architecture.com](http://www.service-architecture.com)

<http://www.w3c.org/2002/ws/arch>

Web Services and Service-Oriented Architectures: The Savvy Manager's Guide  
by Douglas K. Barry



# QUEST (Quick Unbiased Efficient Statistical Tree): An efficient algorithm of Classification Tree in Data Mining

<sup>1</sup>Mr. U. N. Parmar, <sup>2</sup>Mr. A. K. Ranpura, <sup>3</sup>Mr. V. K. Jadeja, <sup>4</sup>Mr. R. P. Joshi  
<sup>1,3,4</sup>Lecturer, Dept of IT, CCET, Wadhwan, Gujarat., <sup>2</sup>Lecturer, MCA Dept, CCET, Wadhwan, Gujarat.  
ureshparmar13@yahoo.co.in, [ranpura.avalik.2007@gmail.com](mailto:ranpura.avalik.2007@gmail.com), [vkjadeja\\_itworld@yahoo.co.in](mailto:vkjadeja_itworld@yahoo.co.in), [rah1985@gmail.com](mailto:rah1985@gmail.com)

**Abstract:-** Classification trees based on exhaustive search algorithms tend to be biased towards selecting variables that afford more splits. As a result, such trees should be interpreted with caution. In this paper QUEST (QUICK UNBIASED EFFICIENT STATISTICAL TREE) algorithm is proposed which has negligible bias. Its split selection strategy yields binary splits and the final tree can be selected by a direct stopping rule or by pruning. Real and simulated data are used to compare QUEST with the exhaustive search approach. QUEST is shown to be substantially faster as QUEST generates random no. of trees like forests and the size and classification accuracy of its trees are typically comparable to those of exhaustive search. QUEST classifies the data from dataset file like ARFF. QUEST works with categorical as well as continuous attributes. QUEST gives the better result compare to other existing classifiers such as SimpleCart, ID3, J48 etc. QUEST gives the statistical binary decision tree. It is the tree structured classification algorithm which gives the efficient tree. QUEST also does pruning and deals with missing values using cross validation. QUEST uses the univariate splits to split the node instead of surrogate splits. This thesis gives detailed description about the QUEST algorithm.

## 1. INTRODUCTION

In Data Mining, many Decision Tree classification methods are available. But each method has some drawback. The basic decision tree method ID3, which can easily generate the tree but neither prune the tree nor deals with missing values. Same way CHAID generates non binary decision tree but takes time to generate the tree. First the basic decision tree algorithm ID3 has been found. But it was having many disadvantages. So many new decision tree algorithms were enhanced from basic and some problems can be solved by new algorithms. But day by day data becomes larger. So there is a need to classify the data from large dataset quickly with good accuracy. QUEST which stands for QUICK UNBIASED EFFICIENT STATISTICAL TREE can classify data more quickly and with low cost because QUEST has negligible bias. So by using QUEST algorithm the problem of classifying data quickly from large dataset can be easily solved. QUEST generates a binary decision tree; therefore it is easy to classify the data using QUEST [3] [5].

QUEST uses statistical imputation instead of surrogate splits as in CART. For both ordered variable and categorical variable, different split point selection method is used. [3]. QUEST also deals with missing values. QUEST is based on statistics; therefore it uses imputation for missing values. are two methods- Hot Deck imputation and Regression imputation. Hot-deck imputation fills in missing values on incomplete records using values from similar, but complete records of the same dataset. Regression computation is commonly used when auxiliary data are available. [8][7]

The QUEST algorithm can be used in applications such as Medical Research, Chemical Laboratory, Food Chemistry, Weather Forecasting, Neural Network etc.

## 2. CONCEPT OF CLASSIFICATION

Classification is a data mining (machine learning) technique used to predict group membership for data instances. Classification and prediction are two form of data analysis that can be used to extract models describing important data classes or to predict future data trends for which the classifiers are used [9].

### 2.1 Classification Methods

#### 2.1.1 Decision Tree

A decision tree is a flow chart like tree structure in which each branch (nonleaf) node represents a choice between a number of alternatives, and each leaf (terminal) node represents a classification or decision. A decision tree can be used to classify an example by starting at the root of the tree and moving through it until a leaf node, which provides the classification of the instance.

Decision Trees are so popular just because, its construction does not require any domain knowledge or parameter setting, and is appropriate for exploratory knowledge discovery. Decision trees can handle high dimensional data. Their representation of acquired knowledge in tree form is intuitive easy to assimilate. The learning and classification steps of decision tree induction is simple and fast. In general Decision Tree classifiers have good accuracy.

In advantages of Decision Trees it can handle both nominal and numeric input attributes, can handle datasets that may have errors, handle datasets having missing values, it may reduce cost even if the cost of classification is high and no need of domain knowledge.

In disadvantages of Decision tree that most of its algorithms have discrete values as target values, reduce performance in complex interactive attributes, sometimes provide over-sensitivity to the training set, and sometimes deteriorate when handling too much missing values.

### 2.1.2 Binary Decision Tree

Binary Decision Trees (BDTs) are essentially computer science binary tree structures, enabling a conclusion state to be reached from a root node (which you could think of as a question or decision choice) via a set of binary (yes/no) decision states. In more down-to-earth terms, it is a technique to allow a conclusion to be made based on a specified problem definition. Decision trees are a popular technique in classification systems as well as in computer game AI and there are a whole host of related algorithms of interest, e.g. ID3. A BDT comprises of a set of body nodes which are attached to a root node and which terminate at n leaf nodes. The root and each body node must have connections to two other nodes; otherwise they are classed as terminating nodes where a decision outcome state has been reached. The uniform design of the tree based on two nodes leads to it being called a binary decision tree.

The leaf nodes in a BDT represent a set of terminating "answers" or decision outcome states as I have called them, the root and body nodes representing the "questions". The BDT arrives at a decision state by gaining answers to the body (yes/no) nodes. The nature of the response to a particular question dictates which node should be followed to the next question (or answer if a leaf node is arrived at). In the case of a binary decision tree the responses can only be "yes" or "no", each corresponding to one of the two available branches at each body node.

### 2.1.3 Various Advanced Decision Trees

**1. ID3:** The ID3 algorithm is considered to be very simple decision tree algorithm. Using information gain as splitting criteria, ID3 ceases to grow when all instances belong to a single value of a target feature or when best information gain is not greater than zero. ID3 does not apply any pruning process nor handles missing values.

**2. C4.5:** It is an evolution of ID3 which uses gain ratio as splitting criteria. The splitting ceases when number of instances to be split is below a certain threshold. Error based pruning is performed after the growing phase. C4.5 can handle numeric attributes. It can also induce from the training set that incorporates missing values by using corrected gain ratio criteria.

**3. CART:** CART stands for Classification and Regression tree. CART partitions the data into two subsets so that the records

within each subset are more homogeneous than in the previous subset. It is a recursive process—each of those two subsets is then split again, and the process repeats until the homogeneity criterion is reached or until some other stopping criterion is satisfied. It also enables users to provide prior probability distribution.

**4. CHAID:** A CHAID stands for Chi Squared automatic interaction detection was originally designed to handle nominal attributes only. CHAID evaluates all of the values of a potential predictor field. It merges values that are judged to be statistically homogeneous (similar) with respect to the target variable and maintains all other values that are heterogeneous (dissimilar). CHAID "build" non-binary trees based on a relatively simple algorithm that is particularly well suited for the analysis of larger datasets.

**5. QUEST:** It is a relatively new binary tree-growing algorithm (Loh and Shih, 1997). It deals with split field selection and split-point selection separately. The univariate split in QUEST performs approximately unbiased field selection. That is, if all predictor fields are equally informative with respect to the target field, QUEST selects any of the predictor fields with equal probability. QUEST affords many of the advantages of CART, but, like CART, your trees can become unwieldy. You can apply automatic cost-complexity pruning to a QUEST tree to cut down its size. QUEST uses surrogate splitting to handle missing values.

## 3. COMMON CRITERIAS OF ANY TREE BASED CLASSIFICATION METHOD.

**Merging** – relative to the target variable, non-significant predictor categories are grouped with the significant categories.

**Splitting** – selecting the split point. Variable to split population is chosen by comparison to all others.

**Stopping** – rules which determine how far to extend the splitting of nodes.

**Pruning** – branches that add little to the predictive value of the tree are removed.

## 4. QUEST ALGORITHM

**Algorithm:** Generate a binary decision tree using QUEST Algorithm

**Input:**

- € Dataset D, which is a set of training tuples and their associated class labels
- € Attribute\_list, which is the set of candidate attributes
- € Attribute\_selection Method, a procedure used to split the node and partition the data into individual classes.

**Output:** A Statistical Binary Decision Tree

## Method:

1. Create the Root node R
2. If tuples in D are all of the same class c, then return R as a leaf node labeled with the class C
3. If attribute\_list is empty then return R as a leaf node labeled with the majority class in D
4. Else Association between each input attribute and target attribute is computed using ANOVA-F test if attribute is ordinal or Chi-square test if attribute is categorical
5. If attribute is multi nominal then clustering is used to create two super classes. The attribute that obtains the highest association with the target attribute is selected for splitting.
6. Apply the stopping criteria
7. Prune the tree using Pre-pruning or Post-pruning.
8. Apply ten fold cross validation to deal with Missing values
9. Output the binary decision tree

**Fig 1. The QUEST Algorithm**

QUEST (Quick, Unbiased, Efficient, Statistical Tree) is a binary-split decision tree algorithm for classification and data mining technique. The objective of QUEST is similar to that of the CART (classification and Regression) algorithm but the major differences are:

- € QUEST uses an unbiased variable selection technique by default
- € QUEST uses imputation instead of surrogate splits to deal with missing values.
- € QUEST can easily handle categorical predictor variables with many categories

A *variable selection scheme* is proposed for constructing multivariate classification trees. It utilizes conditional independence test derived from hierarchical log linear model for three-way contingency table to control selection bias. Furthermore, it is compared with some existing selection methods in terms of selection power. Simulation results show that our method is unbiased and has better selection power.

QUEST is shown to be substantially faster and the size and classification accuracy of its trees are QUEST that

- 1) has negligible variable selection bias
- 2) Retains the computational simplicity of FACT technique
- 3) Includes pruning as an option
- 4) Yields binary splits

QUEST method is demonstrated to be much better than exhaustive search in terms of variable selection bias and computational cost.

QUEST is a tree-structured classification algorithm that yields a binary decision tree like CART. The reason for yielding a binary tree is that a binary tree may allows techniques such as *pruning, direct stopping rules and surrogate splits* to be used. Unlike CHAID and CART, which handle variable selection and split point selection simultaneously during the tree growing

process. QUEST was demonstrated to be much better than exhaustive search methods in terms of variable selection bias and computational cost. In terms of classification accuracy, variability of split points and tree size, however, there is still no clear winner when univariate splits are used.

For each split, the association between each input attribute and the target attribute is computed using the ANOVA-F test or Leven's test(for ordinal and continuous attribute) or Pearson's Chi-Square (for nominal attribute). An ANOVA F-statistics is computed for each attribute. If the largest F-statistics exceeds a predefined threshold value, the attribute with the largest F-value is selected to split the node. Otherwise, leven's test for unequal variance is computed for every attribute. If the largest levene is greater than a predefined threshold value, the attribute with the largest levene value is used to split the node..

If the target attribute is multinomial, two means clustering is used to create two super-classes. The attribute that obtains the highest association with the target attribute is selected for splitting.

## 4.1 Advantages of QUEST Algorithm compared to other Decision Tree Algorithms

- € Variable selection Bias
- € Computational Accuracy/Computational cost
- € Variability of split points & Tree size
- € QUEST is shown to be substantially faster and the size and classification accuracy of its trees are comparable to these of exhaustive search.

## 4.2 Components of QUEST analysis

Basic components in a QUEST analysis are as follows:

- € *One or more predictor variable:* Predictor variables can be continuous, ordinal or nominal variables.
- € *One target variable:* The target variable must be nominal.
- € *Settings for various QUEST parameters:* The settings include alpha level for variable selection, priors for the categorical target variable, profit values and misclassification costs, and the variable used as the frequency weight variable.

## 4.3 Comments on QUEST analysis

- € With categorical dependent variables only.
  - € If it is important to have an unbiased tree.
  - € If you have a large or complex data set and need an efficient algorithm for estimating the tree.
  - € Or CART, if you want to restrict your tree to binary splits.
  - € If the classification model produced by QUEST is measurably better than that produced by the other methods.
  - € CART to handle missing values by surrogate splits.
  - € Case weight is ignored in the QUEST option.
- Like CHAID, the cost matrix is not directly involved in the

QUEST tree growing process.

However, for a symmetric cost matrix, cost information can be incorporated into the model by adjusting the priors based on the cost matrix.

#### 4.4 Stopping Rules

Each of the methods recursively splits nodes until one of the stopping rules is triggered.

The following conditions will cause the algorithm to terminate:

- € The maximum tree depth has been reached.
- € No more splits can be made, because all terminal nodes meet one or more of the following conditions:
- € There is no significant predictor variable left to split the node.
- € The number of cases in the terminal node is less than the minimum number of cases for parent nodes.

#### 4.5 Dealing with missing values

QUEST uses *statistical imputation* instead of surrogate splits while handling missing values.

Surrogate splitters are used to classify rows that have missing values in the primary splitter. When a row is encountered that has a missing value on the primary splitter.

#### Data Imputation for Missing Values

Two of the most commonly used techniques by QUEST for data imputation are *hot-deck imputation* and *regression imputation*.

**Hot-deck imputation** fills in missing values on incomplete records using values from similar, but complete records of the same dataset.

**Regression imputation** is commonly used to compensate for item non response when auxiliary data are available. It is common practice to compute survey estimators by treating imputed values as observed data and using the standard unbiased (or nearly unbiased) estimation formulas designed for the case of no non response.

### 5. EXPERIMENTS AND RESULT

To evaluate the performance of the QUEST we are using some of the well known UCI (University of California Irvine) datasets [10]. The performance of the classification-based method is affected by several factors such as the number of records, the number of attributes, the number of records on which model is built, amount of missing values etc.

Table1 describes the three different UCI datasets with number of instances that we have used for performance study.

Dataset	No of Instances
Soybean	5000
Mushroom	9000
Waveform	10000

**Table 1. Summary of datasets**

The QUEST algorithm's performance is tested & compared with other existing algorithms such as J48, DecisionStump,

SimpleCart. Compared to other algorithms, QUEST is giving better accuracy. The comparison using Soybean dataset is given in table 2 and relevant graph is given in fig 2.

Classifier	Accuracy(Soybean)
QUEST	93.41
J 48	91.50
Decision Stump	28
Simple Cart	91.21

**Table 2. Classifier vs Accuracy**

We have also done comparison with Mushroom and Waveform datasets with different number of instances. We found that most of the cases QUEST giving better result.

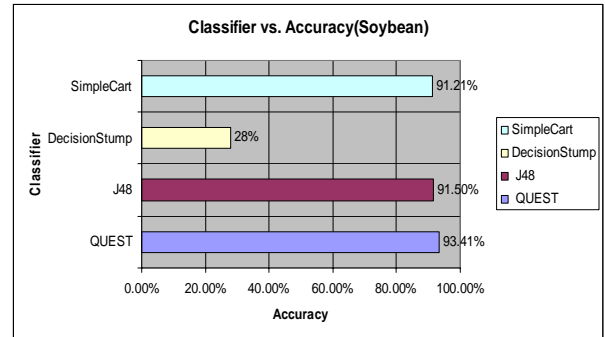

**Figure 2. Comparison of different classifiers' accuracy on Soybean dataset using WEKA tool. (Accuracy shows in percentage). The x-cordinates shows the accuracy, y-cordinates shows classifiers.**

### 6. CONCLUSION

This paper comprehensively shows how the QUEST algorithm being run and also done the comparison of QUEST with other classifiers with large datasets. So we can conclude that with negligible bias, binary split strategy and stopping rules, QUEST generating attractive results as compare with other classifier trees.

## 7. REFERENCE

- [1] Narsimha Raju Alluri : “Evaluation of Data Mining Methods to support Data Warehouse Administration”, University of Applied Sciences, Furtwangen-Germany, 2005.
- [2] Wei Peng, Juhua Chen and Haiping Zhou: “An Implementation of ID3 Algorithm”, University of New South Wales, Sydney-Australia, 1997
- [3] Wei-Yin Loh and Yu-Shan Shih: “Split selection Methods for Classification Trees”, University of Wisconsin-Madison, 1997.
- [4] Mike Cameron-Jones and Andrew Charman-Williams: “Stacking for Misclassification Cost Performance”, University of Tasmania, Australia, 1999.
- [5] Loh and Shih: “Comparison of Old and New Classification Algorithms”, Machine learning 2000.
- [6] Yu Shan Shih: “QUEST User Manual”, National Chung Cheng University, Taiwan, 2004.
- [7] Hendrik Blockeel & Jan Struyf: “Efficient algorithms for Cross Validation”, Katholieke University, Belgium, 2002.
- [8] Paul E. Utgoff, Neil C. Berkman, “Decision Tree Induction Based on Efficient Tree Restructuring” Clouse Department of Computer Science, North Carolina A&T State University, Greensboro, NC 27411.
- [9] U N Parmar, A K Ranpura, S J Agravat, “Multiple Classifier System using bagging method”, vol 4, issue 1, IJTES international journal, Sangli, Jan 2010.
- [10] Machine learning UCI dataset repository  
<http://www.ics.uci.edu/mllearn/MLRepository.html>

# Performance Analysis of Gun-shot Direction Detection System for ak47 gun shot

<sup>1</sup>Anju M. Vasdewani <sup>2</sup>Dr. G.R.kulkarni <sup>3</sup>R.S.Gajre

<sup>1</sup> Student, M.E. (E.C.), C.U.Shah College of Engineering & Technology, Wadhwan City

<sup>2</sup>Principial, C.U.Shah College of Engineering & Technology, Wadhwan City

<sup>3</sup>Asst.Prof of Electronics & Communication Department

[amvasdewani@aits.edu.in](mailto:amvasdewani@aits.edu.in) [grkulkarni29264@rediffmail.com](mailto:grkulkarni29264@rediffmail.com) [rakeshgajre@gmail.com](mailto:rakeshgajre@gmail.com)

**ABSTRACT:-THIS SYSTEM CAN DETECT THE SOURCE OF GUN FIRE. THE WORKING PRINCIPLE OF THE SYSTEM IS THAT SOUND WAVES TRAVEL AT FINITE SPEED AND A SINGLE SOUND PICKED UP BY MULTIPLE MICROPHONES SPATIALLY DEPLOYED, WOULD BE OFFSET IN TIME. IN SIMPLE PARLANCE, THE MICROPHONE WHICH IS NEAREST TO THE SOUND SOURCE WILL PICK UP THE SOUND FIRST AND THAT WHICH IS FARTHEST WILL BE THE LAST TO HEAR IT. TO MAKE THE USE OF THIS PRINCIPLE IN A PRACTICABLE GADGET, NUMEROUS MICROPHONES ARE PLACED IN SPECIFIC MANNER IN TWO PLANES AND THE OUTPUT OF EACH MICROPHONE IS CONNECTED TO A PROCESSING CIRCUIT. THE PROCESSING CIRCUIT HAS TO ACCOMPLISH SOME VERY IMPORTANT TASKS. THE FIRST WOULD BE TO AUTHENTICATE THE SOUND AS A AK47 GUN SHOT AND TO STOP THE SYSTEM FROM GENERATING FALSE ALARMS WHEN IT PICKS UP A FIRE CRACKER OR A TIRE BURST. TO DO THIS SOUND COMPARISON ALGORITHM IS BEING IMPLEMENTED USING MATLAB. ONCE THIS IS DONE THE REST OF THE PROCEDURE IS VERY STRAIGHT FORWARD. THE DELAY BETWEEN TWO MICROPHONES IN HORIZONTAL PLANE WILL DETERMINE THE DIRECTION OF GUN FIRE.THE INSTRUMENT CAN BE A GREAT HELP TO THE MILITARY AND OTHER SECURITY FORCES ON PATROL. SUCH AN INSTRUMENT WOULD BE A BOON TO SECURITY FORCES IN SURVIVING GUERILLA ATTACKS IN MILITANCY INFLECTED AREAS SUCH AS THE KASHMIR VALLEY AND THE EASTERN STATES. THE DISPLAY OF THE SYSTEM CAN BE CONSTRUCTED IN ANY WAY AS THE USER WOULD LIKE IT FOR INSTANCE IF THE MILITARY IS ABOUT TO USE IT, A PREFERABLE DISPLAY WOULD BE A CLOCK LIKE DIAL WITH LEDs MOUNTED AT DIFFERENT 'O CLOCKS' WITH WHICH THEY ARE VERY FAMILIAR ALONG WITH SOME AUDIO WARNING. IN SUCH A SYSTEM IF THE SYSTEM DETECTS THAT A SHOT HAS BEEN FIRED FROM THE FRONT THE 12 O CLOCK LED WILL LIGHT UP. THIS SYSTEM CAN ALSO BE MOUNTED ON PATROLLING VEHICLES.**

## Field of the Invention

The present invention generally relates to gunshot detection. More particularly, the present invention is directed to using multiple installations of sound detection, recording devices for detecting firing of a gun or an explosion, identifying of a location of such firing or explosion, and of a possible suspect of such firing or explosion.

It would therefore be desirable to provide a system to detect a gunshot, determine the direction from which it was fired, and initiate recording of the area of the event immediately upon the event occurring.

Here the task is divided into three different parts

- 1) Comparing input signal(gun shot or other sound) with stored ak47 gun shot, which decides whether direction is to be detected or not
- 2) Using parallel port of computer for indication if input signal is gun shot. Direction detection hardware is going to

display direction only when input signal is gunshot and output of parallel port is 1.

3) Hardware of direction detection consists of 8 microphones, supported by 8 preamplifiers and monostable multivibrators. Output of all 8 multivibrator is provided to port of microcontroller, and based on which input comes first direction is detected.

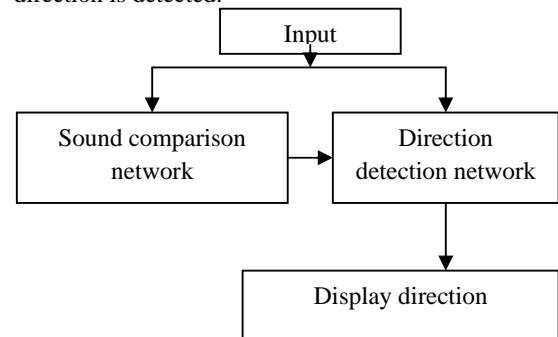

Figure 1: Layout of system

Figure 1 shows flow layout of system in which the whole task is divided into 2 portions. Signal comparison and direction detection. As shown in figure signal comparison loop and direction detection loop are working in parallel. When any input signal (acoustic in nature) comes, microphone that is connected to signal comparison loop picks up a sound and is given as an input to matlab for comparison purpose to decide whether input is ak47 or not. At a same time microphones connected to direction detection system would pick up sound and will determine direction as per input from which microphone is coming first. Result of direction is stored in one of the working register of direction detection circuit.

Direction detection circuit will not display the output till it will get input from signal comparison network. If input signal is ak47 then output of one parallel port line is given to direction detection circuit to inform that input was ak47. Then direction will be displayed.

## Comparison of input signal

First task is to compare input signal with pre stored gun shot signal continuously. Using wavread command, matrix of stored signal is generated and using wavrecord command matrix of input signal is generated. Then using algorithm for comparison between two sounds their similarity is checked.

Comparison between two signals(audio signals) can be done using cross correlation which is the basic method of comparing frequency components of two signals. Figure 2 shows original ak47 signal and figure 3 shows recorded signal.



Figure 2: Original ak47 signal

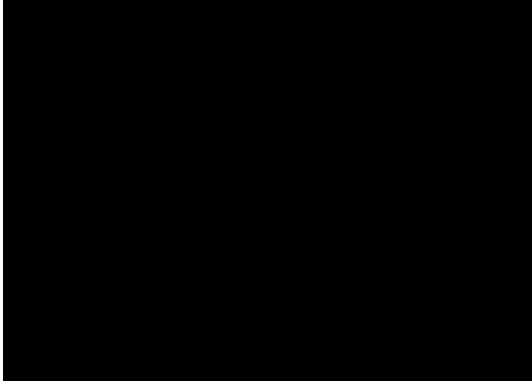

Figure 3: Recorded ak47 signal

As shown in above case as microphone was very near to source of gunshot there is 82.252% of cross correlation between input and stored sound.

Similarly table 1 shows cross correlation factor of original ak47 sounds with other signals. Here based on user's accuracy requirement system parameter for accuracy can be modified. It can be easily achieved that if cross correlation factor is greater than some threshold level then output of parallel port will be high other wise it will be low.

Another requirement of real time system is time required for processing should be as small as possible other wise if processing time is more then, required task of pointing suspected region ( if this system is used for security) can not be achieved. Processing time can only be reduced by doing some signal processing on input signal. For example if input signal is below some threshold and that can be defined by range of device. So that if input is less than some threshold, direction will not be displayed.

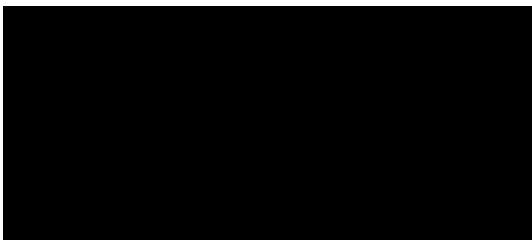

Figure 4: Truncated part of original ak47

Suppose ak47 is of 2 second signal, then recording cannot be done for exactly 2 second but more than 2 seconds. Solution to above problem can be achieved by truncating the portion which is below some threshold level so comparison time required will be less. Here figure 2 shows original ak47 and figure 3 shows recorded ak47. Direction comparison between them requires atleast 6 minutes to check whether recorded signal is ak47 or not, whereas comparison between their truncated part as shown in figure 4 and figure 5 respectively requires only 1 minute and 18 seconds for comparison purpose.

Other sound	Crosscorrelation(%)
Ak47	100
Ak47b	82.252
Ak47l	44.917
Explo	3.7
Explob	3.8
Gs	6.09
Gsb	6.149
Spoken word	6.88

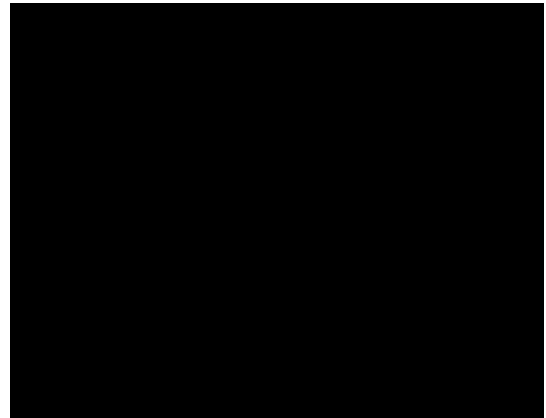

Figure 5: Truncated part of recorded ak47

## SYSTEM FOR DIRECTION DETECTION

### Introduction

Presently I have devised a system that senses direction with the help of only two microphones. Later I intend to construct a system that uses eight microphones to sense the direction of the sound source from all the four directions. The block diagram of the system is as shown in Figure 6. The sound is picked up simultaneously by the two condenser microphones for direction detection and one dedicated microphone having good frequency response is used as an input transducer for recording purpose and comparison purpose for computer. The outputs of these microphones are quite low and thus are amplified by their corresponding identical pre amplifiers. These amplified signals are used to trigger two different monostables. Both these monostables have identical time periods. The outputs of these monostables are used to provide interrupt to the microcontroller. The output of the system is a clock dial type led display which is driven by the controller port which has been configured as the output port by the software.

Table 1: Cross correlation factor of ak47 with other sounds

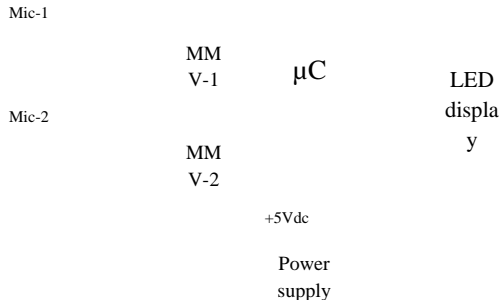

Figure 6: Block diagram of direction detection system using 2 microphones

Presently my system is working for two directions only i.e. north and south or it can be said that its resolution is 180 degree. Figure 7 shows flow chart of direction detection system.

As shown in figure 6 direction detection system is after initialization waiting for input. If there is any acoustic signal present then depending on place of gun fire (i.e. source of sound wave), LED will glow up for some time delay set using software. There are 2 basic problems if above system is used. They are as (1) If there are simultaneous gun shot from different direction then this system will not be able to distinguish whether source of gun fire is from which particular direction. (2) If gun fire is from center (i.e. all microphones receive signal of gun shot simultaneously) then based on which hardware having less propagation delay will generate output first, which gives wrong indication. (as here hardware for all sensors i.e. preamplifier, monostable multivibrator are constructed using same component value but practically due to tolerance they will not be same).

Figure 7: Flowchart of microcontroller based system for direction detection using 2 microphones

Figure 8: Propagation delay between of two similar hardware

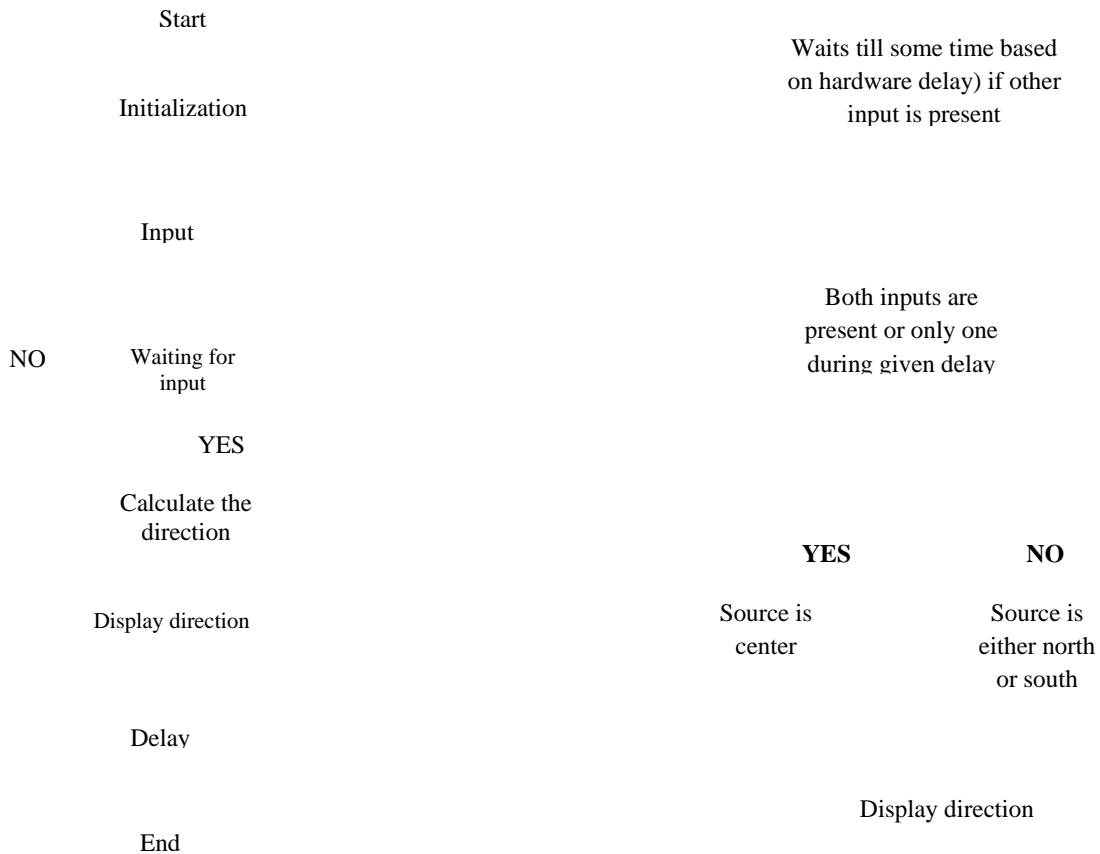



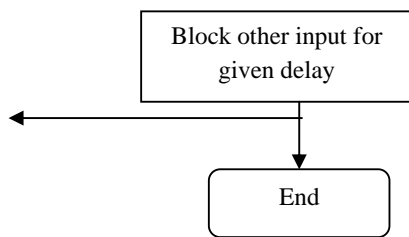

Figure 9: Flowchart of modified system

For solution of 1<sup>st</sup> problem one assumption is made i.e. for given delay only one gun shot can be detected.

If there are simultaneous gun fires then system will not be able to detect every gun shot but is limited to only some which depends what is the delay between gun shots. It is achieved by blocking the input for some time delay.

Solution to 2<sup>nd</sup> problem is made by finding propagation delay of two hardware; one which is faster compared to other is delayed using software technique. i.e. if input to both microphones comes during some prescribed time delay, then source is center other wise it is from any particular direction. Figure 8 shows time delay in two similar hardware measured using DSO.

Solution to above two problems is shown in figure 9 which shows flow chart for two microphone direction detection system. As stated above here another input is blocked after occurrence of one input for some time duration and to get correct center reading additional delay is added using software techniques.

## CONCLUSION

In this dissertation, I have proposed the basic issues in designing gun shot direction detection which is used for military and homeland security. The design has to very sensitive to decide whether gun shot detection was for ak47 so

that false direction detection can be prevented. Also while designing hardware for direction detection one has to think for critical timings of this system, as microcontroller (or any other processor) is responding in microseconds, so delay produced by each hardware should be equal., which challenges the component accuracy. Any change in time delay needs to corrected either in hardware or using software loop.

## REFERENCES

- 1 Muhammad Ali Mazidi, Janice Gillispie Mazidi, Rolin D. Mckinlay, "The 8051 Microcontroller and Embedded", Second Edition, Pearson Prentice Hall, 2006
- 2 Kenneth J. Ayala, "The 8051 Microcontroller Architecture, Programming & Applications", Second Edition, Penram International Publishing (India)
- 3 Lapin, Brett D., Besser, Nicholas D, "Gun shot digital imaging system", United states patent 6965541, 2005
- 4 [www.shotspotter.com](http://www.shotspotter.com)

# MODIFIED BAGGING METHOD: A NOVEL APPROACH OF MULTIPLE CLASSIFICATION IN DATA MINING

Mr. Uresh N Parmar<sup>1</sup> , Mr. Krunal G Patel<sup>2</sup>, Ms. Meenakshi<sup>3</sup>

1,2.Department of Information Technology,  
C.C.E.T, Wadhwan, Gujarat, India

3.Department of Information Technology  
K.I.T.R.C., Kalol, Gujarat, India

[meenakshi.saroha@gmail.com](mailto:meenakshi.saroha@gmail.com), [ureshparmar13@yahoo.co.in](mailto:ureshparmar13@yahoo.co.in)

**Abstract:**-Classification is the process of deriving unknown values of certain attributes of interest based on the values of the other attributes. Multiple classifier system (MCS) has shown to be an effective technique for classification. MCS construct a set of classifiers and then classify new data sets by taking votes of their prediction. Bagging is basically a multiple classifier ensemble based system improving the accuracy of the single base classifier learned on entire data, by using combination of models. In basic bagging approach, different bags (models) are created by sampling (with replacement) of the original training data set. Each bagged train set is independently used to generate a classifier, and classifier predictions are combined using as a simple majority voting system. However there is no guarantee that bagging will improve the performance of the base classifier every time, in some situations it fails to do so. Also bagging may work deterioratically in large dataset as well.

The main objective of the paper is to overcome the above defined problem, by using the same bootstrapping and aggregating method. Bagged predictors are constructed discarding the bootstrap samples which generate the accuracy which is less then the base classifier accuracy considering the involvement of the base classifier at the time combining all the models. The approach would be quite effective improving the accuracy of the base classifier as well as basic bagging classifier in a situation when bagging fails sometimes to do so.

## 1. INTRODUCTION

In matters of great importance that have financial, medical, social, or other implications, we often seek a second opinion before making a decision, sometimes a third, and sometimes many more. In doing so, we weigh the individual opinions, and combine them through some thought process to reach a final decision that is presumably the most informed one.

The process of consulting “several experts” before making a final decision is perhaps second nature to us; yet, the extensive benefits of such a process in automated decision making applications have only recently been discovered by computational intelligence community.

Also known under various other names, such as multiple classifier systems, committee of classifiers, or mixture of experts, ensemble based systems [2][3] have shown to produce favorable results compared to those of single-expert systems for a broad range of applications and under a variety of scenarios. Popular ensemble based algorithms, such as bagging, boosting, stacked generalization, and hierarchical mixture of experts.

A supervised machine learning task involves constructing a mapping from input data (normally described by several features) to the appropriate outputs. In a classification learning task, each output is one or more classes to which the input belongs. The goal of classification learning is to develop a model that separates the data into the different classes, with the aim of classifying new examples in the future.

Given a new example, the ensemble passes it to each of its multiple *base* models, obtains their predictions, and then combines them in some appropriate manner (e.g., averaging or voting).

## 4. CONCEPT OF BOOTSTRAPPING

Bootstrap is sampling with replacement from a sample. Bootstrapping is the practice of estimating properties of an estimator (such as its variance) by assuming set of observations to be from an independent and identically distributed population, this can be implemented by constructing a number of resamples of the observed dataset (and of equal size to the observed dataset), each of which is obtained by random sampling with replacement from the original dataset. It may also be used for constructing hypothesis tests. The advantage of bootstrapping over analytical methods is its great simplicity.

MCS is a meta-algorithm uses bootstrapping to improve machine learning of classification and regression models in terms of stability and classification accuracy.

### 3. CLASSIFIERS

Classification is a data mining (machine learning) technique used to predict group membership for data instances. Classification and prediction are two forms of data analysis that can be used to extract models describing important data classes or to predict future data trends for which the classifiers are used.

Basically two types of classifiers: Stable and Unstable. The most popular and commonly used stable classifiers are – Fisher Linear Discriminant (FLD) and Nearest Mean Classifier (NMC), and unstable are – Decision Tree, Decision Stumps [5]. MCS uses C4.5 Decision Tree Classifier as a base.

### 4. ENSEMBLE SYSTEM

An ensemble method for classification tasks constructs a set of base classifiers from the training data and performs classification by taking a vote on the prediction of each base classifier. Many traditional machine learning algorithms generate a single model (e.g., a decision tree or neural network). Ensemble learning methods instead generate multiple models.

#### 4.1 Reasons for using Ensemble Based System

There are several theoretical and practical reasons why we may prefer an ensemble system:

##### Statistical Reasons:

A set of classifiers with similar training performances may have different generalization performances. In fact, even classifiers with similar generalization performances may perform differently in the field.

##### Large Volumes of Data:

In certain applications, the amount of data to be analyzed can be too large to be effectively handled by a single classifier. Partitioning the data into smaller subsets, training different classifiers with different partitions of data and combining their outputs using an intelligent combination rule often proves to be a more efficient approach.

##### Too Little Data:

In the absence of adequate training data, resampling techniques can be used for drawing overlapping random subsets of the available data, each of which can be used to train a different classifier, creating the ensemble. Such approaches have also proven to be very effective.

##### Divide and Conquer:

Regardless of the amount of available data, certain problems are just too difficult for a given classifier to solve. More specifically, the decision boundary [3] that separates data from different classes may be too complex, or lie outside the space of functions that can be implemented by the chosen classifier model.

#### 4.2 Diversity

If we had access to a classifier with perfect generalization performance, there would be no need to resort to ensemble techniques. The realities of noise, outliers and overlapping data distributions, however, make such a classifier an impossible proposition. At best, we can hope for classifiers that correctly classify the field data *most of the time*. The strategy in ensemble systems is therefore to create many classifiers, and combine their outputs such that the combination improves upon the performance of a single classifier. This requires,

however, that individual classifiers make errors on different instances. The intuition is that if each classifier makes different errors, then a strategic combination of these classifiers can reduce the total error, a concept not too dissimilar to low pass filtering of the noise. The overarching principle in ensemble systems is therefore to make each classifier as unique as possible, particularly with respect to misclassified instances.

Classifier diversity [3] can be achieved in several ways. The most popular method is to use different training datasets to train individual classifiers. Such datasets are often obtained through resampling techniques, such as bootstrapping or bagging, where training data subsets are drawn randomly, usually with replacement, from the entire training data.

#### 4.3. Creating an Ensemble

Two interrelated questions need to be answered in designing an ensemble system: i) how will individual classifiers (base classifiers) be generated? And ii) how will they differ from each other? The answers ultimately determine the diversity of the classifiers, and hence affect the performance of the overall system.

Therefore, any strategy for generating the ensemble members must seek to improve the ensemble's diversity. In general, however, ensemble algorithms do not attempt to maximize a specific diversity measure. Rather, increased diversity is usually sought—somewhat heuristically—through various resampling procedures or selection of different training parameters. The above defined diversity measures can then be used to compare the diversities of the ensembles generated by different algorithms.

### 5. BAGGING METHOD

In data mining, a model generated by machine learning can be regarded as an expert. Expert is probably too strong a word – Depending on the amount and quality of the training data, and whether the learning algorithm is appropriate to the problem. An obvious approach to making decisions more reliable is to combine the output of different models. Several machine learning techniques do this by learning ensemble of models and using them in combination: prominent among these are schemes called bagging, boosting, and stacking. All are used to increase the predictive performance over a single model. And they are general techniques that can be applied to numeric prediction problems and to classification tasks [1].

The simplest way to do this in the case of the classification is to take the vote (majority vote); in the case of numeric prediction, it is calculating the average vote. So Bagging uses majority voting (for classification) or averaging (for numeric prediction) to combine the output of individual models.

Bagging is a statistical re-sample and combining technique used to reduce the misclassification error of a base classifier. It is based on *bootstrapping and aggregating* techniques.

## 6. BAGGING ALGORITHM

Input:

- €  $D$ , a set of  $d$  training tuples;
- €  $K$ , the number of models in the ensemble;
- € A learning scheme (e.g. decision tree algorithm, back propagation, etc.)

Output: A composite model,  $M^*$ .

Method:

- for  $i = 1$  to  $k$  do // create  $k$  models
- create bootstrap sample,  $D_i$ , by sampling  $D$  with replacement;
- use  $D_i$  to derive a model,  $M_i$ ;
- endfor;

To use the composite model on a tuple,  $X$ :

- if classification then
- let each of the  $k$  models classify  $X$  and return the majority vote;
- if prediction then
- let each of the  $k$  models predict a value for  $X$  and return the average predicted value.

**Fig. 1. The Bagging Algorithm**

Given a set,  $D$ , of  $d$  tuples, bagging works as follows. For iteration  $i$ , ( $i = 1, 2, \dots, k$ ), a training set,  $D_i$ , of  $d$  tuples is sampled with replacement from the original set of  $D$  tuples. Note that the term Bagging stands for *bootstrap aggregation*. Each training set is a bootstrap sample. To classify an unknown tuple  $X$ , each classifier,  $M_i$ , returns its class prediction, which counts as one vote. The bagged classifier,  $M^*$ , counts the votes and assigns the class with the most votes to  $X$ . Bagging can be applied to the prediction for a given test tuple. The algorithm is summarized in the fig. 4.6. The increased accuracy occurs because the composite model reduces the variance of the individual classifiers.

Although the bagging algorithm has been known to be known in increasing the accuracy of prediction of the base unstable classifiers constructing bootstrap samples from training sets and then aggregating to form a final predictor, the main problem with this method is that *there is no guarantee that bagging will improve the performance of any base classifier every time* [1]. The other problem may arise when there is a large dataset of training tuples are there, in that case bagging would not be much effective.

## 7. MCS ALGORITHM

MCS is a modified bagging algorithm using C4.5 as a base classifier, aggregating the models discarding the classifier generating weak result.

The bootstrapping and aggregating is in following way.

- Input:**
- 1) A set of training tuples
  - 2) The number of models (bootstrap) in the ensemble
  - 3) A learning scheme (Decision Tree here)

**Output:** A composite model

**Method:**

- (1) Initialization of the training set & testing set from given data set.
- (2) Apply training data to the base learning, generate a model and calculate accuracy ( $ACC_{base}$ )
- (3) Repeat for number of times (as number of bootstrap)
  - (a) Create bootstrap sample, by sampling with replacement the original training set.
  - (b) Apply base learner on each bootstrap and calculate accuracy, ( $ACC_{boot}$ ).
  - (c) Compare  $ACC_{boot}$  with  $ACC_{base}$
  - (d) If  $ACC_{base} < ACC_{boot}$ 
    - (i) Consider base model as bootstrap model else
    - (ii) Consider bootstrap model
- (4) Calculate majority voting for classification and average accuracy for prediction

**Fig. 2. The MCS Algorithm**



**Figure 3 The figurative view of the MCS algorithm**

The dataset is taken, and then it is divided in to training set and testing set according to holdout method in which 2/3 of the set is taken as the training set and remaining 1/3 used as a testing set.

Select the base learner classifier (here D.T.C4.5) and apply training data and calculate accuracy, which is called  $ACC_{base}$ .

Create number of bootstraps by doing sample with replacement method on the original training set. Take one bootstrap and apply base learner on it and generate accuracy,  $ACC_{boot}$ . Do this process for each of the bootstraps.

Now compare  $ACC_{boot}$  with  $ACC_{base}$ . if the accuracy of the bootstrap model is less than the accuracy of the base model, then at particular time the accuracy of the base model will be considered as a model for final decision, else the accuracy of the bootstrap model will be considered.

Calculate the majority voting method for better classification and aggregating for prediction.

## 8. EXPERIMENTS AND RESULTS

To evaluate the performance of the MCS e are using five of the ell known UCI (University of California Irvine). The performance of the classification-based method is affected by several factors such as the number of records, the number of attributes, the number of records on which model is built, number of bootstraps etc.

Table1 describes the six different UCI datasets with number of instances that we have used for performance study.

Dataset	No of Instances
Credit-G	1000
Optdigits	5620
Weather	13918

Ecoli	20502
Adult	32561
Wisconsin	65156

**Table 1. Summary of datasets**

Table 2 describes the comparison between Bagging and MCS with C 4.5 as a base classifier. We can see that the accuracy is incremented in case of MCS.

Dataset	Bagging with C4.5 (%)	MCS
Credit-G	74.05	82.05
Optdigits	93.92	94.56
Weather	90.57	91.20
Ecoli	87.93	88.10
Adult	79.21	82.27
Wisconsin	95.04	95.10

**Table 2. Accuracy performance (Bagging Vs MCM)**

We have also compared Bagging and MSC with all the datasets using REPTree and Decision Stumps as base classifiers. In all the comparison we got improved results in MSC then in Bagging.

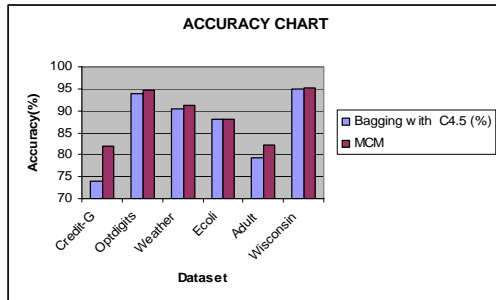

**Figure 3. Comparison of Bagging and MCS (Multiple Classifier System) using WEKA tool. The x-coordinates shows different datasets, y-coordinates shows accuracy in percentage.**

So, we can say that because of the instability of the base classifier, Bagging may fail to improve performance of base classifier, also bagging may work deterioratically in some large benchmark datasets as well. In that situation MCS may help to improve that.

## 9. CONCLUSION

This paper comprehensively shows the comparison between MCS algorithm and Bagging using C4.5 as a base classifier. Due to the instability of the base classifiers (i.e. Decision Tree C4.5), there is no guarantee that bagging will improve the performance of the base classifier every time. MCS eliminates the limitations of Bagging on benchmark datasets and improves the accuracy.

## 10. REFERENCES

- [1] BREIMAN, L., "Bagging Predictors", Technical Report 421, Department of Statistics, University of California, Berkeley.1994
- [2] David Opitz, Richard Maclin (1999). "Popular Ensemble Methods: An Empirical Study". Journal of Artificial Intelligence Research 11 (1999) 169-198.
- [3] ROBI POLIKAR, "Ensemble based system in decision making", IEEE Circuits and system magazine, Third Quarter, 2006.
- [4] Nikunj C. Oza, (2004). "Ensemble Data Mining Methods".
- [5] FAISAL ZAMAN, "A Robust Method Using Median as a Combination Rule", IEEE 8<sup>th</sup> international conference, DOI 10.1109, IT workshop 56,
- [6] J. R. Quinlan, (2006). "Bagging, Boosting, and C4.5".
- [7] KRISTINANA MACHOVA, FRANTISEK BARCAV, PETER BENDAR, "A bagging method using Decision Tree in the role of base classifiers", technical University, Letna, 2006
- [8] GIORGIO FUMERA, Member, "A theoretical analysis of bagging as a linear combination of classifiers", IEEE, and Alessandra Serrau,2008
- [9] Machine learning UCI dataset repository <http://www.ics.uci.edu/mllearn/MLRepository.html>

# EMISSION SCENARIO AT ROAD INTERSECTIONS : A CASE STUDY OF SURAT CITY

Asst.Prof Jayesh A. Shah, Principal Dr. F.S.Umrigar, Ast.Prof Dr L.B.Zala, Ast.Prof Neeraj D.Sharma  
V.B.T.Engg.College , Umrah  
B.V.M Engg. College , V.Vidyanagar

**ABSTRACT-:***Indian urban areas are experiencing drastic growth in vehicular population due to most classical reasons of speedy industrialization and urbanization growth . Upshots of such growth are delay and increase traffic congestion on roads, up surging of travel time and fatal accidents and beyond all these the most objectionable issue of increasing pollution levels in urban bases. This paper is an attempt to focus on the pollution level on some of the significant intersections of Surat city in Gujarat.*

## INTRODUCTION

The tremendous increase in mobilization of human society has resulted in phenomenal rise in vehicular traffic on the major roadways. The vehicles discharge an appreciable amount of exhaust emission, which consist of poisonous gases like carbon monoxide, sulphur dioxide, oxides of nitrogen etc. The emission from the vehicles cause adverse effects on plants ,human beings, animals, soil and other environmental components, However every urban area dominance some significant points, regions, stretches of traffic with heavy air pollution and the road intersections are the most critical locations in urban region ,where air pollution is at predominant stage. Presently world survey points out that many developed urban regions are under the influence of air pollution due to vehicular population and many of them have reported the major level of such emission at traffic road intersections due to one or another reasons which may be due to improper practice

of maintaining vehicles , improper operation , old age vehicles , unrealistic design of road intersections or lacking or signalized intersection etc. ,Among these

many cities , megacities , towns of India are facing nastiest scenario at various temporal stages during the year.

The present study is carried out at Surat city which is considered as one of the most developed city of Gujarat state in India. However due to fast development and expansion of city Surat is also experiencing the classical issues of urban transportation like traffic congestion , traffic delay and the most crucial issue of urban air pollution. Here efforts are carried out to recognize most air pollution stimulating traffic intersections in the city and traffic volume surveys alongwith mission survey for CO and HC pollutants have been conducted at some of such intersections during some peak duration.

## MATERIAL AND METHODS

Primarily on the base of present scenario of city traffic as well data of RTO-Surat & Surat Municipal Corporation (SMC) city area is classified on the base of primary and secondary traffic intersections where air pollution fluctuates, however during such classification it is taken care that same categories of intersections are grouped in same group .(*This identification of road intersections includes only intense pollution prone intersections, so not all intersections of city are included and it is also to be noted that survey work is carried out only at some of the following intersections till, remaining is under progress-Some more intersections may be identified at later stage of survey*). Such categories of road intersections are defined on the base of traffic density, use of such intersections during day and night, average pollution level ,traffic delay on such intersection etc. According to this two categories of road intersections , i.e primary and secondary are designated under this survey.(List of existing intersections under these categories are listed in Table-1 ).Mixed traffic conditions were observed during survey work at peak and slack timings.

**Table-1 Identified Primary Intersections**

<b>Sr No</b>	<b>Name of Intersection</b>	<b>Assigned Id</b>	<b>Type of Intersection</b>	<b>Name of Road</b>
1	Gujarat Gas Circle	P1	Four arm Signalized roundabout	Hazira Road
2	Palanpur Patia	P2	T-Type signalized	Rander Road
3	Sona Restaurant	P3	Four arm signalized	Rander Road
4	Navyug College	P4	Four arm staggered signalized	Rander Road
5	Sargam Shoping Centre	P5	Four arm staggered Signalized	Dumas Road
6	Chopati	P6	T-Type signalized	Dumas Road
7	Athwagate flyover bridge	P7	Four arm staggered signalized	Dumas Road-Ring Road
8	Majura Gate Circle	P8	Four arm staggered signalized	Ring Road
9	Chowk Circle	P9	Four arm signalized	Stn Road
10	Sahara Darwaja	P10	T-Type staggered signalized	Ring Road
11	Delhi Gate	P11	Four arm signalized	Stn Road

**Table-2 Identified Secondary Intersections**

<b>Sr No</b>	<b>Name of Intersection</b>	<b>Assigned Id</b>	<b>Type of Intersection</b>	<b>Name of Road</b>
1	Choksi wadi	S1	T-Type signalized	Kadvapatidarwadi Arterial Road
2	Bhulka Bhavan	S2	T-Type signalized	Hazira Road
3	Rishabh Circle	S3	Four arm signalized	Rander Road
5	Bhagal Circle	S4	Four arm Signalized	Stn Road

**Sample Collection & Analysis**

Among all identified intersections survey was carried out at two primary intersections (Chowk Circle and Gujarat Gas Circle) where parameters of CO and HC were measured with CO-HC Analyzer PEA 205-Indus auto exhaust monitor gas analyzer from vehicles under idling engine conditions. Both these gases are detected by Non dispersive infrared(NDIR) method. The instrument measure CO in percentage and HC in ppm in the stream of exhaust gas. The analyzer uses the principle of non dispersive infrared technique for measurement. By the consideration of study point of view random sampling was carried out from the fleet of the traffic

flow ,however Surat Traffic police supported during such survey. 1000 Nos. of 2 -Wheelers ,500 Nos. of 3-Wheelers Petrol vehicles samples selected for survey work. Age of vehicle has been considered as significant variable for the analysis part.

**RESULTS AND DISCUSSION**

Average emission levels of CO and HC using CO-HC analyzer at both the intersections are tabulated in Table 2 and its graphical presentation is shown in Figure-1

**Table 2: Average CO and HC Emission**

Vehicles	Age (years)	Type of Engine/Ignition	Samples Taken for Survey	Average Emission	
				CO (%)	HC(ppm)
3-Wheelers	More than 10	2 Stroke	90	3.9	6750
3-Wheelers	More than 10	4 stroke	10	3.48	5875
2-Wheelers	More than 10	2 Stroke	100	3.55	6680
2-Wheelers	More than 10	4 stroke	150	3.22	4672
3-Wheelers	Less than 10	2 Stroke	250	3.12	4880
3-Wheelers	Less than 10	4 stroke	150	2.88	3660
2-Wheelers	Less than 10	2 Stroke	350	2.90	4518
2-Wheelers	Less than 10	4 stroke	400	2.32	3050

**\* Combined includes two and four stroke engine for 2 Wheelers**

Above results at two selected intersections indicates that comparatively 3-Wheelers contributes more concentration of Carbon Monoxide and Hydrocarbons to the environment and also the contribution of such parameters are more from 2 Stroke vehicles than 4 Stroke Vehicles.

**Figure-1 Chart Representing the CO & HC Emission scenario at Selected Intersections of Surat City**



## FUTURE WORK

Above scenario represents the need of detail survey at another intersections and model study of vehicular exhaust emission, However such thing can be carried out with conventional way of stastical modeling approach but with the modern trend of research has now opened the research prospects with geospatial base where numerous factors can be considered simultaneously for modeling analysis of pollutant emission at respective geo referenced locations. GIS and GPS are the best modeling tools and analytical approach for this. Multi decision making can also be incorporate with the introduction of GIS and GPS study of identified intersections. So in such regard these two and other road intersections are planned to map with GPS and configured with GIS for detailed analysis of pollutant behaviour at typical intersection and it can be easily verified by implementing the model at same type and same traffic patterned intersection.

## CONCLUSION

As from the obtained results it appears that Old aged vehicles are prone to cause much emission of CO and HC than the new i.e (having the age less than 10 years) and also 2 Strokes vehicles are found with more concentration of CO and HC than 4 Stroke. It is interested to note that despite of same type vehicles(i.e-2 stroke or 4-stroke) emission was found different due to vehicular age factor, adulteration of fuel, etc. Such factors should be analyzed simultaneously to get more concrete outcome of the modeling study to be carried out at said intersection. However in present case study survey was preliminary level survey but detail survey with more parameters and by incorporating seasonal variations is required to create geospatial model for the air pollution study at these and other remaining primary and secondary road intersections.

## REFERENCES

1. Bandopadhyay S.N., "Automobile Air Pollution and its control, Indian Highways, 1996
2. Dr. Satu Kush, "Automobile Pollution", 1<sup>st</sup> ed., IVY Publishing House, Delhi, 2001.
3. Hayashi & Roy(1995),"Transport Land use and Environment" Kluwer, Boston
4. Rao C.S(2001), " Environmental Pollution Control Engineering", New Age International Pvt. Ltd., New Delhi
5. S.Vijay Kumar,"Traffic and transport impact on Environment-An Overview",Feb-1997
6. Sharma N.D (2003),,"Vehicular Pollution Growth:- A Trend of Surat City", *Proc., Urban Air Pollution :Issues & Management* ,National Conference at SVNIT –Surat ,pp-2-76
7. Tailor R.(2002),,"Metropolitan Travel Behaviour Analysis: A Case study of Surat City". *MTRP Dissertation*, SVNIT, Surat
8. Umrigar F.S., (2003)"Urban Transport Plan-Let us Move Urbanities-Not Automobiles:., *Journal of Engineering & Technology, Sardar Patel University*, Vol-16-pp-II-III

# Performance Comparison of Space Time Codes

Anshu Shah, Asst Prof. Gandhinagar Institute of Technology, Gandhinagar  
M. Salim, Asst Prof, MNIT, Jaipur  
Prof. R.P. Yadav, MNIT, Jaipur

**Abstract:** Space-time coding is a technique used in wireless communications to transmit multiple copies of a data stream across a number of antennas and to exploit the various received versions of the data to improve the reliability of data-transfer. The fact that transmitted data must traverse a potentially difficult environment with scattering, reflection, refraction and so on as well as be corrupted by thermal noise in the receiver means that some of the received copies of the data will be 'better' than others. This redundancy results in a higher chance of being able to use one or more of the received copies of the data to correctly decode the received signal. In fact, space-time coding combines all the copies of the received signal in an optimal way to extract as much information from each of them as possible. This paper presents performance evaluation of concatenated Space Time code in Rayleigh Fading environment. This code uses Space Time Trellis Code as Outer code and space Time Block Code as inner code. Hence providing advantage of diversity of STBC along with STTC's decoding advantage

## Section-1

### Space Time Block Codes: Introduction

In the case of STBC in particular, the data stream to be transmitted is encoded in blocks, which are distributed among spaced antennas and across time. While it is necessary to have multiple transmit antennas, it is not necessary to have multiple receive antennas, although to do so improves performance [1]. This process of receiving diverse copies of the data is known as diversity reception and is what was largely studied until Foschini's 1998 paper.

An STBC is usually represented by a matrix. Each row represents a time slot and each column represents one antenna's transmissions over time.

#### A. Alamouti scheme with two transmitter one receiver [2]

The scheme uses two transmit antennas and one receive antenna and may be defined by the following three functions:

- The encoding and transmission sequence of information symbols at the transmitter;
- The combining scheme at the receiver;
- The decision rule for maximum likelihood detection.

**1) The Encoding and Transmission Sequence:** At a given symbol period, two signals are simultaneously transmitted from the two antennas. The signal transmitted from antenna zero is denoted by  $s_0$  and from antenna one by  $s_1$ . During the next symbol period signal  $(-s_1^*)$  is transmitted from antenna zero, and signal  $s_0^*$  is transmitted from antenna one where  $*$  is the complex conjugate operation. This sequence is shown in Table I.

	TX ant0	TX ant1
Time t	$s_0$	$s_1$
Time t+T	$-s_1^*$	$s_0^*$

**Table 1: the notation for the transmitted signals at the two transmit antennas**

Here encodings is done in space and time. The channel at a time t is modeled by a complex multiplicative distortion  $h_0(t)$  for transmit antenna 1 and  $h_1(t)$  for transmit antenna 2. We assume that the fading is constant across 2 consecutive symbols .

$$h_0(t) = h_0(t + T) = h_0 e^{j\theta} ; h_1(t) = h_1(t + T) = h_1 e^{j\theta} \quad (1)$$

where T is the symbol duration. The Receiver symbols can now be expressed as

$$r_0(t) = r_0(t + T) = h_0 s_0 + h_1 s_1 + n_0$$

$$r_1(t) = r_1(t + T) = -h_0 s_1^* + h_1 s_0^* + n_1 \quad (2)$$

Where  $r_0$  and  $r_1$  are received signals at a time t and t+T and  $n_0$  and  $n_1$  are complex random variable representing receiver noise and interference. Received signal  $r_0$  consist of signals  $s_0$  and  $s_1$  and received signal  $r_1$  consist of the conjugate  $s_1^*$  and  $s_0^*$  To determine the transmitted signals, we have to uncouple the 2 equations and extract out measures of the transmitted signals from these equations .This is done in the combiner the combiner is associated by the channel estimator which provides perfect estimation of the channel parameters.

The main advantages of the Alamouti scheme is that simple signal processing is performed to separate the signals  $s_0$  and  $s_1$  respectively the estimates of the transmitted signals are formed as

$$\tilde{s}_0 = h_0^* r_0 + h_1 r_1^*$$

$$\tilde{s}_1 = h_1^* r_0 - h_0 r_1^* \quad (3)$$

so after solving the equations results obtained

$$s_0 \sim = \begin{pmatrix} 1 & 0 \\ 0 & 1 \end{pmatrix} s_0 + h_0^* n_0 + h_1 n_1^*$$

$$s_1 \sim = \begin{pmatrix} 1 & 0 \\ 0 & 1 \end{pmatrix} s_1 - h_0 n_1^* + h_1^* n_0 \quad (4)$$

The maximum likelihood decoder must now yield the symbols transmitted over two symbol interval. For the case of PSK the decision rule can be simplified to,

Decide in the favor of signal point  $s_i$  if

$$d^2(s_0 \sim, s_i) \leq d^2(s_0 \sim, s_k) \quad \text{such that } i \in \tilde{N} \quad k.$$

A similar rule can be stated for receiver estimate  $s_i \sim$  also

Decide in the favor of signal point  $s_j$  if

$$d^2(s_1 \sim, s_j) \leq d^2(s_1 \sim, s_k) \quad \text{such that } j \in \tilde{N} \quad k$$

if the similar signal is received by two antennas then the decoder equation will be:

$$s_0 \sim = h_0^* r_0 + h_1 r_1^* + h_2^* r_2 + h_3 r_3^*$$

$$\Rightarrow s_0 \sim = \begin{pmatrix} 1 & 0 \\ 0 & 1 \end{pmatrix} s_0 + h_0^* n_0 + h_1 n_1^* + \begin{pmatrix} 0 & 1 \\ 1 & 0 \end{pmatrix} \begin{pmatrix} h_2^* r_2 + h_3 r_3^* \\ h_2^* n_2 + h_3^* n_3 \end{pmatrix}$$

$$s_1 \sim = h_1^* r_0 - h_0 r_1^* - h_2^* r_3 + h_3 r_2^*$$

$$s_1 \sim = \begin{pmatrix} 1 & 0 \\ 0 & 1 \end{pmatrix} s_1 + h_1^* n_0 - h_0 n_1^* + \begin{pmatrix} 0 & 1 \\ 1 & 0 \end{pmatrix} \begin{pmatrix} h_3^* n_2 - h_2 n_3^* \\ h_2^* r_3 + h_3 r_2^* \end{pmatrix}$$

**Table 2- the definition of channels between the transmit and receive antennas**

	RX ant0	Rx ant 1
TX ant 0	$h_0$	$h_2$
TX ant 1	$h_1$	$h_3$

And

**Table 3 -the notation for the received signals at the two receive antennas**

	RX ant0	Rx ant 1
Time t	$r_0$	$r_2$
Time T+t	$r_1$	$r_3$

	TX ant0	TX ant1
Time t	$s_0$	$s_1$
Time t+T	$-s_1^*$	$s_0^*$

The recovered signal are then applied to ML detector, which works in he similar fashion stated above.

### Higher order STBCs

Tarokh et al. discovered a set of STBCs [3][4] that are particularly straightforward, and coined the scheme's name. They also proved that no code for more than 2 transmit antennas could achieve full-rate. Their codes have since been improved upon (both by the original authors and by many others). Nevertheless, they serve as clear examples of why the rate cannot reach 1, and what other problems must be solved to produce 'good' STBCs. They also demonstrated the simple, linear decoding scheme that goes with their codes under perfect channel state information assumption.

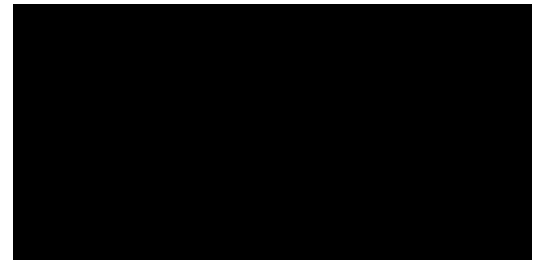
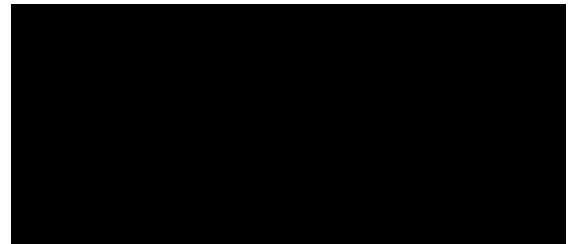

### Simulation Results:

#### Assumptions:

1. Receiver has Perfect Knowledge of channel.
2. Channel is assumed to be Rayleigh with zero mean and unity variance.
3. Frame size is taken as 8 bits.

Under the aforementioned assumptions simulation is done using MATLAB. The simulation results are shown below for Alamouti scheme applied on the following and the results are also shown for them respectively:

1. 2 transmitter and 1 receiver system using BPSK constellation
2. 2 transmitter and 2 receiver scheme using BPSK constellation
3. 2 Transmitter and 2 receiver scheme using QPSK constellation.

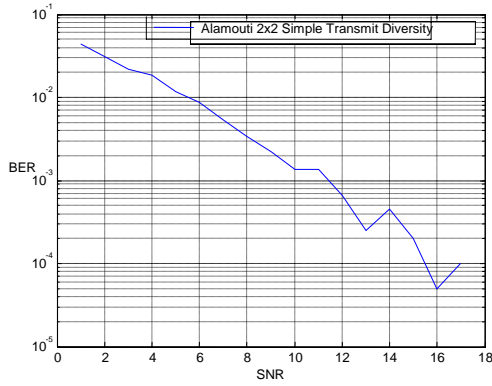

Fig 1: 2 transmitter and 1 receiver system using BPSK constellation

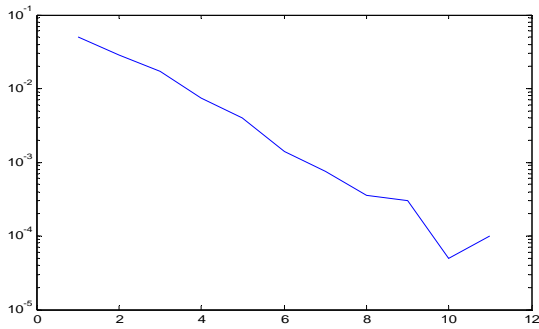

Fig 2: 2 transmitter and 2 receiver scheme using BPSK constellation

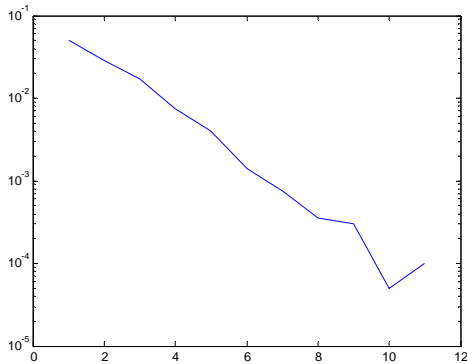

Fig.3: 2 Transmitter and 2 receiver scheme using QPSK constellation

It can be seen from the BER characteristics that with the Alamouti Scheme good error performance can be achieved at lower SNR. The BER performance is independent of modulation used so using this scheme even a lower complexity modulation system can perform better. Improvement in Performance can be achieved using diversity. i.e. the system performance can be increased significantly by increasing the number of transmitting and receiving antennas.

## Section II

### 1) Space Time Trellis Codes: Introduction

Space-Time Coding (STC) is an open loop transmission scheme that was introduced by V. Tarokh[5]. In STC, joint design of channel coding and modulation is done to create efficient transmission techniques which improve system performance by providing both the diversity advantage of multiple transmit antennas and coding gain. In [5], space-time codes based on trellis-coded modulation (TCM) are presented. These codes are called Space-Time Trellis Codes (STTC) and their performance was shown to be very good in slow Rayleigh fading environments. The receiver for these STTC schemes uses Maximum Likelihood Sequence Estimation (MLSE) and the decoding complexity for these schemes (measured in terms of number of trellis states) increases exponentially with transmission rate for a fixed number of transmit antennas.

Space-time trellis codes (STTC) are a type of space-time code used in multiple-antenna wireless communications. This scheme transmits multiple, redundant copies of a trellis (or convolutional) code distributed over time and a number of antennas ('space'). These multiple, 'diverse' copies of the data are used by the receiver to attempt to reconstruct the actual transmitted data. For a STC to be used, there must necessarily be multiple *transmit* antennas, but only a single *receive* antennas is required; nevertheless multiple receive antennas are often used since the performance of the system is improved by so doing.

In contrast to space-time block codes (STBCs), they are able to provide both coding gain and diversity gain and have a better bit-error rate performance. However, being based on trellis codes, they are more complex than STBCs to encode and decode; they rely on a Viterbi decoder at the receiver where STBCs need only linear processing [5].

Space-Time block codes can achieve a maximum possible diversity advantage with a simple decoding algorithm. It is very attractive because of its simplicity. However, no coding gain can be provided by space-time block codes, while non-full rate space-time block codes can introduce bandwidth expansion[7]. STTC was first introduced by Tarokh, Seshadri and Calderbank [4]. It was widely discussed and explored in the literature as STTC can simultaneously offer a substantial coding gain, spectral efficiency, and diversity improvement on flat fading channels.

### B. Encoder Structure for STTC

For space-time trellis codes, the encoder maps binary data to modulation symbols, where the mapping function is described by a trellis diagram. Let us consider an encoder of space-time trellis coded M-PSK modulation with  $n_T$  transmit antennas as shown in Fig.1[6].

The input message stream, denoted by  $c$ , is given by[6]

$$c \mid (c_0, c_1, c_2, \dots, c_t) \quad (3.1)$$

where  $c_t$  is a group of  $m \mid \log_2 M$  information bits at time  $t$  and given by

$$c_t \mid (c_t^1, c_t^2, \dots, c_t^m)$$

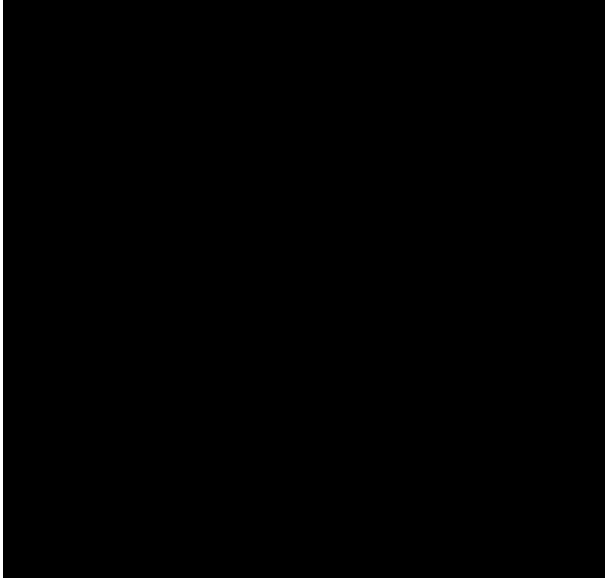

Fig. 4. Encoder for STTC

The encoder maps the input sequence into an M-PSK modulated signal sequence, which

is given by

$$x \mid (x_0, x_1, \dots, x_t, \dots) \quad (5)$$

where  $x_t$  is a space-time symbol at time  $t$  and given by

$$x_t \mid (x_t^1, x_t^2, \dots, x_t^{n_T})^T \quad (6)$$

The modulated signals,  $x_t \mid (x_t^1, x_t^2, \dots, x_t^{n_T})^T$ , are transmitted simultaneously through  $n_T$  transmit antennas.

## Generator Description

In the STTC encoder as shown in Fig.1,  $m$  binary input sequences  $c^1, c^2, \dots, c^m$  are fed into the encoder, which consist of  $m$  feed-forward shift registers. The  $k$ -th input sequence  $c^k \mid (c_0^k, c_1^k, \dots, c_t^k, \dots)$ , is passed to the  $k$ -th shift register and multiplied by an encoder coefficient set. The multiplier outputs from all shift registers are added modulo  $M$ , giving the encoder output  $x_t \mid (x_t^1, x_t^2, \dots, x_t^{n_T})^T$ . The connections between the shift register elements and the modulo  $M$  adder can be described by the following  $m$

multiplication coefficient set sequences

$$\begin{aligned} g^1 & \mid [(g_{01}^1, g_{02}^1, \dots, g_{0n_T}^1), (g_{11}^1, g_{12}^1, \dots, g_{1n_T}^1), \dots, (g_{n-1,1}^1, g_{n-1,2}^1, \dots, g_{n-1,n_T}^1)] \\ g^2 & \mid [(g_{01}^2, g_{02}^2, \dots, g_{0n_T}^2), (g_{11}^2, g_{12}^2, \dots, g_{1n_T}^2), \dots, (g_{n-1,1}^2, g_{n-1,2}^2, \dots, g_{n-1,n_T}^2)] \\ & \dots \\ g^m & \mid [(g_{01}^m, g_{02}^m, \dots, g_{0n_T}^m), (g_{11}^m, g_{12}^m, \dots, g_{1n_T}^m), \dots, (g_{n-1,1}^m, g_{n-1,2}^m, \dots, g_{n-1,n_T}^m)] \end{aligned} \quad (7)$$

where  $g_{j,i}^k, k = 1, 2, \dots, m, j = 1, 2, \dots, k, i = 1, 2, \dots, n_T$  is an element of the M-PSK constellation set, and  $k$  is the memory order of the  $k$ -th shift register.

The encoder output at time  $t$  for transmit antenna  $i$ , denoted by  $x_t^i$ , can be computed as

$$x_t^i \mid \prod_{k \mid 1}^m \prod_{j \mid 0}^{n_T} g_{j,i}^k c_{t+j}^k \text{ mod } M, i = 1, 2, \dots, n_T \quad (8)$$

These outputs are elements of an M-PSK signal set. Modulated signals from the space time symbol transmitted as time  $t$

$$x_t \mid (x_t^1, x_t^2, \dots, x_t^{n_T})^T \quad (9)$$

The space-time trellis coded M-PSK can achieve a bandwidth efficiency of  $m$  bits/s/Hz.

The total memory order of the encoder, denoted by  $k$ , is given by

$$Y \mid \prod_{k \mid 1}^m Y_k \quad (10)$$

Where  $Y_k$ , is the memory order for the  $k$ -th encoder branch. The value of  $Y_k$  for M-PSK constellations is determined by

$$Y_k = \lceil \log_2 M \rceil \quad (11)$$

The total number of states for the trellis encoder is  $2^m$ . The  $m$  multiplication coefficient set sequences are also called the *generator sequences*, since they can fully describe the encoder structure.

### Decoding

For STTC, the decoder employs the Viterbi algorithm to perform maximum likelihood decoding. Assuming that perfect CSI is available at the receiver, for a branch labeled by  $x_t = (x_t^1, x_t^2, \dots, x_t^{n_r})^T$ , the branch metric is computed as the squared Euclidean distance between the hypothesized received symbols and the actual received signals as

$$\sum_{j=1}^{n_r} |r_t^j - h_{j,i}^t x_t^i|^2$$

The Viterbi algorithm selects the path with the minimum path metric as the decoded sequence.

### Simulation Results:

Assumptions:

1. The generator sequences of a 4-state space-time trellis coded QPSK scheme with 2 transmit antennas are assumed to be:  $g_1 = [0 \ 2 \ ; \ 2 \ 0]$  and  $g_2 = [0 \ 1 \ ; \ 1 \ 0]$
2. The encoder takes  $m=2$  bits as its input at each time.
3. The trellis consists of  $2^2 = 4$  states, represented by state nodes.
4. The Channel is assumed to be Rayleigh.
5. The channel is known perfectly at the receiver.

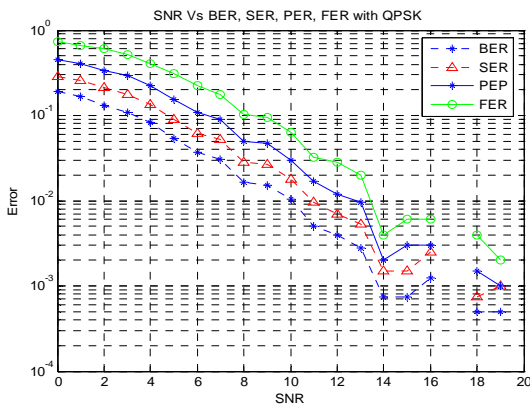

Fig 5: 4-state space-time trellis coded QPSK scheme

From the fig. 5, We can say that Space Time Trellis codes provide improved error performance for wireless systems using multiple antenna. These codes can also provide the full diversity gain as well as coding gain. Performance can be improved by increasing the number of receive antennas but at the cost of increased decoder complexity. Another way to improve performance is either to increase constellation size or opt for higher state STTC.

### Section III

#### Concatenated Space Time Code: Introduction

Concatenation is also frequently employed in space time coded systems. In this case, the outer code is frequently a TCM system whose symbol are transmitted via an inner space time coded system [9][8].

In what follows, we combine space-time block codes with a trellis code to come up with a new structure that guarantees the full diversity with increased rate. Also, we show how to design the trellis code to maximize the coding gain. The result is a systematic method to design space-time trellis codes for any given rate and number of states.

#### The System Model:

The system can be described by the block diagram shown below. Space Time Trellis code is used as outer code and Space Time Block Codes are used as inner code. The data modulator used in the work is QPSK modulator & channel is assumed to be Rayleigh.

If  $x(t)$  represents the input bit stream &  $s(t)$  is the STTC encoded data, we can model the system as:

$$s(t) = \wedge \{x(t)\}_{STTC} \dots \text{i.e. STTC encoding}$$

Here, 4 State STTC is considered and the generator used is the same as was used in STTC encoding.



Fig. 6. Proposed system for concatenated encoder and decoder.

$$\tilde{I} \mid \wedge \{s(t)\}_{STBC} \dots\dots \text{i.e. STBC encoding}$$

The signal  $X_c(t)$  is the 2 bit QPSK modulated signal  $\tilde{I}$ . The QPSK signal may assign any of the four values possible i.e.  $1+i$ ,  $1-i$ ,  $-1+i$  and  $-1-i$ .

The system equation is then written as :

$$Y_c(t) \mid R_c(t) * X_c(t) 2 W(t) \quad (12)$$

$Y_c(t)$  &  $W(t)$  are channel response and channel noise(Rayleigh).

**Design of Concatenated code:**

After defining a system, the next problem is how to implement (Alamouti) on encoded STTC codes. For that purpose again consider the STTC encoder. For convenience it is shown below:

**Implementation of STBC on encoded STTC:**

In this work, following orthogonal design is used as transmission matrices:

$$C(x_1, x_2) \mid \begin{matrix} \textcircled{R} & x_1 & x_2 \\ \textcircled{I} & 4 x_2^* & x_1^* \end{matrix} \quad (13)$$

Where \* denotes the conjugate operation.

Let the output of the STT encoder  $c_1$  and  $c_2$  are represented as:

$$c_1 \mid c_t \mid c_t^1 c_t^2 c_t^3 \dots\dots\dots c_t^n$$

And

$$c_2 \mid c_{t41} \mid c_{t41}^1 c_{t41}^2 c_{t41}^3 \dots\dots\dots c_{t41}^n \quad (14)$$

The data stream can now be encoded according to Alamouti scheme as

$$\tilde{I}(c_1, c_2) \mid \begin{matrix} \textcircled{R} & c_1 & c_2 \\ \textcircled{I} & 4 c_2^* & c_1^* \end{matrix} \quad (15)$$

In this manner without increasing the number of transmitting antennas significant improvement in the performance can be achieved.

**Decoding:**

Decoder structure for the concatenated code is similar to that used previously for STTC and STBC decoders. Let the received signals at the two receive antennas are  $r_1$  and  $r_2$ , the data can be recovered by applying it first to the STBC decoder and extracting the signals  $c_1$  and  $c_2$  as follows:

$$\begin{aligned} c_1 &= h_0^* r_0 + h_1 r_1^* + h_2^* r_2 + h_3 r_3^* \\ c_2 &= h_1^* r_0 - h_0 r_1^* - h_2^* r_3 + h_3 r_2^* \end{aligned} \quad (16)$$

The recovered data streams are then applied to the Viterbi decoder for further decoding.

Fig. 7: Encoder for space time trellis code

## 15 Simulation Results:

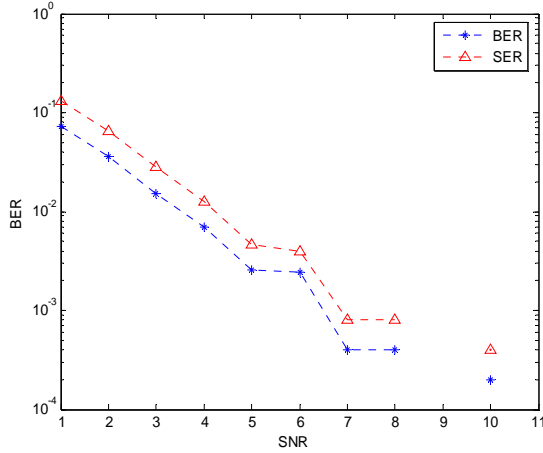

Fig 8: SNR vs BER performance of proposed scheme

For STTC, the decoder employs the Viterbi algorithm to perform maximum likelihood

decoding. Assuming that perfect CSI is available at the receiver, for a branch labeled by

$x_t \mid (x_t^1, x_t^2, \dots, x_t^{n_T})^T$ , the branch metric is computed as the squared Euclidean distance

between the hypothesized received symbols and the actual received signals as

$$\sum_{j=1}^{n_R} \left| r_t^j - \sum_{i=1}^{n_T} h_{j,i}^t x_t^i \right|^2$$

The Viterbi algorithm selects the path with the minimum path metric as the decoded sequence.

In this work, a simple technique is proposed for designing an improved high-rate space-time code. The proposed design was based on a concatenation of an orthogonal space-time block code and an STTC encoder. A high-rate Concatenated-STTC design was achieved by expanding the cardinality of the space time block code before concatenates it with an outer STTC encoder. Signal orthogonality was exploited to keep decoding complexity of the proposed scheme relatively low.

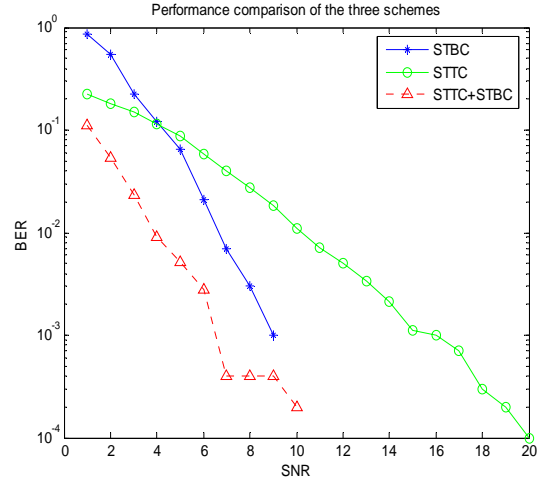

In the above fig. SNR vs. BER performances of three coding techniques using 4 PSK modulation are shown at frame size of 64. We can observe that for an BER of  $10^{-3}$  the required SNR for STBC is 10 dB, for STTC is 17 dB and for concatenated STTC is 7 dB only.

## Section IV

### VII. CONCLUSION

In the thesis work, simulation results are drawn for the three coding schemes namely: Space time Block Codes, Space Time Trellis Codes and Concatenated Space time code where STTC is used as outer code and STBC is used as inner code.

From the simulation results of STBC it can be seen that this code provide performance independent of modulation technique employed. The performance can be further improved by increasing the number of transmit and receive antennas i.e. applying the diversity to this code. The most important point that we can observe is that this code performs with very high efficiency because of orthogonality property under Rayleigh fading environment compared to other codes.

STTC is also simulated and the results are shown in chapter 3 where it has been shown that this code can provide full diversity as well as coding gain. The performance improvement can be achieved by increasing the number of states but it increases receiver complexity. We can also observe that the STTC is sensitive to modulation employed & for getting better performance higher constellation size has to be used [5].

Here, to improve the performance of lower constellation size (we used 4 PSK), Concatenation of STTC with STBC is proposed. The simulation results show that the Concatenated STTC outperforms the two previous methods.



The performance gain that we achieve is at the cost of reduced code rate and increased receiver complexity. If code rate reduction can be tolerated, the proposed scheme shows very good results. Performance can be further improved by increasing the number of transmitting antennas.

*References:*

1. Special Issue on the European Path Toward UMTS, *IEEE Personal Commun. Mag.*, vol. 2, Feb. 1995.
2. Siavash M. Alamouti "A Simple Transmit Diversity Technique for Wireless Communications" *IEEE journal on select areas in communications*, vol. 16, no. 8, october 1998
3. V. Tarokh, H. Jafarkhani, and A.R. Calderbank, "Space time block codes from orthogonal designs", *IEEE Trans. Inform. Theory*, Vol. 45, July 1999.
4. -----," Space time block coding for wireless communication: performance results" *IEEE J. select. Areas commun.* Vol 17, Mar. 1999
5. Vahid Tarokh,, Nambi Seshadri, and A. R. Calderbank, "Space-Time Codes for High Data Rate Wireless Communication: Performance criterion and Code Construction" *IEEE transactions on information theory*, vol. 44, no. 2, march 1998
6. Bahador Amiri "Space-time Trellis codes" thesis.
7. S. Sandhu, R. Heath and Pulraj, " Space time block codes versus space time trellis codes", *ICC* june 2001
8. S. Siwamogsatham and M.P.Fitz, " Improved high rate space time codes via orthogonality and set partitioning",in *proc. IEEE wireless communications and networking conf.* Mar 2002
9. -----, "Improved high rate space time codes via concatenation of expanded orthogonal Block code and M-TCM" in *IEEE ICC* Apr. 2002

# DATA MINING: TERMS AND TECHNIQUES

<sup>1</sup>Mr. Uresh N Parmar, <sup>2</sup>Mr. Krunal G. Patel, <sup>3</sup>Ms. Meenakshi Saroha, <sup>4</sup>Mr. Nishidh S. Chavda

<sup>1,2</sup> Asst. Prof., IT Department, CCET, Wadhwan, Gujarat, India

<sup>3</sup> Lecturer, IT Department, KITRC, Kalol, Gujarat, India

<sup>4</sup> Asst. Prof., CE Department, CIT, Changa, Gujarat, India

ureshparmar13@yahoo.co.in, kgp2003@gmail.com, meenakshi.saroha@gmail.com, nishidhchavda.ce@ecchanga.ac.in

*Abstract:-Data mining, the extraction of hidden predictive information from large database, is a powerful new technology with great potential to help Companies. Data Mining is the search for the relationships and global patterns that exists in large databases but is 'hidden' among the vast amount of data. Data mining achieves different technical approaches, such as clustering, data summarization, and learning classification rules, finding dependency networks, analyzing and detecting anomalies.*

*Data mining activities are usually performed by three different classes of users: such as executives, end users and analysts. These users usually perform three types of data mining activity within a corporate environment: episodic, strategic and continuous data mining. Functions available with data mining are classification, clustering, association and many more. It concerned with marketing, insurance, banking and transportation like applications.*

*Data mining may have problems like uncertainty, missing values, size of the data, data updating and more.*

*The main objective of this paper is to overcome the brief introduction towards the different terms and next generation techniques of data mining.*

## 1. INTRODUCTION

Data mining refers to the Knowledge Discovery in Data bases (KDD). Data mining techniques are identifying nuggets of information or decision making knowledge in bodies of data and extracting these in such a way that they can be put to use classification, prediction, data forecasting and decision making. Data mining is a powerful new technology with great potential to help companies focus on the most important information in their data warehouses.

Data Mining is the search for the relationships and global patterns that exists in large databases but is 'hidden' among the vast amount of data, these relationships represent valuable knowledge about the database and the objects in the database.

Basically data mining is concerned with the analysis of data and the use of software techniques for finding patterns and regularities in sets of data. Data mining analysis process starts with a set of data uses a methodology to develop an optimal representation of the structure of the data during which time knowledge is acquired.

## 1.1 Data mining Architecture



Fig 1. Data mining Architecture

The ideal starting point is a data warehouse containing a combination of internal data tracking all customer contact coupled with external market data about competitor activity. An OLAP (On-Line Analytical Processing) server enables a more sophisticated end-user business model to be applied when navigating the data warehouse [5].

## 2. DATA MINING MODELS

There are two types of model or modes of operation, which may be used to discover information of interest to the user."

### 2.1 Verification Model

The verification model takes input from the user and tests the validity of it against the data. The emphasis is with the user who is responsible for formulating the hypothesis and issuing the query on the data to affirm or negate the hypothesis.

The problem with this model is the fact that no new information is created in the retrieval process but rather the queries will always return records to verify or negate the hypothesis. The user is discovering the facts about the data using a variety of techniques such as queries, multidimensional analysis and visualization to guide the exploration of the data being inspected."

### 2.2 Discovery Model

The discovery model differs in its emphasis in that it is the system automatically discovering important information hidden in the data. The data is sifted in search of frequently occurring patterns, trends and generalizations about the data without intervention or guidance from the user."

### 3. DATA MINING PROCESS

Following are the processes/stages identified in Data Mining and Knowledge Discovery. The phrases depicted start with the raw data and finish with the extracted knowledge, which was acquired as a result of the following stages:

3.1 Data Selection: Examining the entire raw data set identifies the target subset of data and the attributes of interest. This includes selecting or segmenting the data according to some criteria e.g. all those people who own a car, in these way subsets of the data can be determined.

3.2 Data Cleaning: In this step, noise and outliers are removed, field values are transformed to common units and combining existing fields to facilitate analysis creates some new fields. The data is typically put into a relational format, and several tables might be combined in a de normalization step. Also the data is reconfigured to ensure a consistent format as there is a possibility of inconsistent formats because the data is drawn from several sources e.g. sex may recorded as f or m and also as 1 or 0.

3.3 Transformation: The data is not merely transferred across in that overlays may be added such as demographic overlays in the market research. The data is made usable.

3.4 Data mining: This stage is concerned with the extraction of patterns from the data. Data mining algorithms can be applied to extract the interesting patterns of data.

3.4 Interpretation and Visualization: The patterns identified by the system are interpreted into knowledge, which can then be used to support human decision-making e.g. prediction and classification tasks, summarizing the contents of a database or explaining observed phenomena. The patterns are presented to end users in an understandable form, e.g. through visualization[1].

### 4. DATA MINING NEXT GENERATION TECHNIQUES.

Data mining techniques are as follows:

#### 4.1 Cluster Analysis

In an unsupervised learning environment the system has to discover its own classes. We can cluster the data in the database as shown in the Figure 1. The first step is to discover subsets of related objects and then find descriptions e.g. D1, D2, D3 etc., that describe each of these subsets.

**Fig 2. Discovering clusters and descriptions in a database**

Clustering and segmentation basically partition the database so that each partition or group is similar according to some criteria. Clustering/segmentation in databases are the processes of separating a data set into components that reflect a consistent pattern of behavior.

#### 4.2 Induction

Induction is the inference technique, which can be used to infer the generalized information from the database. Induction has been used in the following ways within data mining.

##### 4.2.1 Decision trees

Decision trees are simple knowledge representation and they classify examples to a finite number of classes, the nodes are labeled with attribute names, the edges are labeled with possible values for this attribute and the leaves labeled with different classes. Objects are classified by following a path down the tree,

by taking the edges, corresponding to the values of the attributes in an object.



The following is an example of objects that describe the weather at a given time. The objects contain information on the outlook, humidity etc. Some objects are positive examples denote by P and others are negative i.e. N. Classification is in this case the construction of a tree structure, illustrated in the



figure 2 which can be used to classify all the objects correctly.

**Fig 3. Decision tree structure**

#### 4.2.2 Rule Induction

A data mine system has to infer a model from the database that is it may define classes such that the database contains one or more attributes that denote the class of a tuple is the predicted attributes while the remaining attributes are the predicting attributes. Class can then be defined by condition on the attributes. When the classes are defined the system should be able to infer the rules that govern classification. Production rules have been widely used to represent knowledge in expert systems and they have the advantage of being easily interpreted by human experts because of their modularity i.e. a single rule can be understood in isolation and doesn't need reference to other rules. The structure of such rules is in the form of if-then rules.

#### 4.2.3 Neural Networks

Neural networks are an approach to computing that involves developing mathematical structures with the ability to learn. Neural networks can derive meaning from complicated or imprecise data and can be used to extract patterns and detect trends that are too complex to be noticed by either humans or other computer techniques. A trained neural network can be thought of as an "expert" in the category of information it has been given to analyze. Neural networks identify patterns or trends in data, they are good for prediction or forecasting. Neural networks use a set of processing elements (or nodes) analogous to neurons in the brain. These processing elements are interconnected in a network that can then identify patterns in data once it is exposed to the data, i.e. the network learns from experience just as people do. This distinguishes neural networks

from traditional computing programs that simply follow instructions in a fixed sequential order. The structure of a neural network is shown in the figure 4.

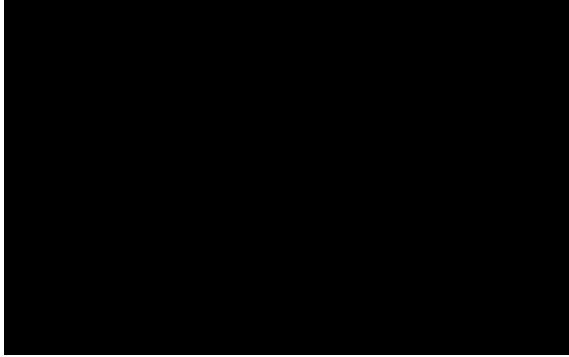

**Fig 4. Structure of Neural Network**

The bottom layer represents the Input layer, in this case with 5 input labels X1 through X5. The middle layer is called the hidden layer, with a variable number of nodes. The output layer in this case has two nodes, Z1 and Z2 representing output values we are trying to determine from the inputs. Neural networks suffered from long learning times, which become worse as the volume of data grows [2].

#### 4.2.4 Data Visualization

Data visualization makes it possible for the analyst to gain a deeper, more intuitive understanding of the data and can work well for data mining. Data mining allows the analyst to focus on certain patterns and trends and explore in-depth using visualization. The volume of data in a database can overwhelm the data visualization but in conjunction with data mining can help with exploration.

## 5. DATA MINING FUNCTIONS

Data mining methods may be classified by the function they perform or according to the class of application they can be used in. The data mining functions are as follows.

### 5.1 Classification

The clustering techniques analyze a set of data and generate a set of grouping rules that can be used to classify future data. The mining tool automatically identifies the clusters, by studying the pattern in the training data. Once the clusters are generated, classification can be used to identify, to which particular cluster, input belongs. For example, one may classify diseases and provide the symptoms, which describe each class or subclass [5].

### 5.2 Association

Given a collection of items and a set of records, each of which contain some number of items from the given collection, an association function is an operation against this set of records which return patterns that exist among the collection of items. These patterns can be expressed by rules such as "72% of all the records that contain items A, B and C also contain items D and E." The specific percentage of occurrences (in this case 72) is called the

confidence factor of the rule. Also, in this rule, A, B and C are said to be on an opposite side of the rule to D and E. Associations can involve any number of items on either side of the rule.

A typical application that can be built using an association function is *Market Basket Analysis*. Thus, by invoking an association function, the market basket analysis application can determine affinities such as "20% of the time that a specific brand toaster is sold, customers also buys a set of kitchen gloves and matching cover sets."

A supervised machine learning task involves constructing a mapping from input data (normally described by several features) to the appropriate outputs. In a classification learning task, each output is one or more classes to which the input belongs. The goal of classification learning is to develop a model that separates the data into the different classes, with the aim of classifying new examples in the future.

Given a new example, the ensemble passes it to each of its multiple base models, obtains their predictions, and then combines them in some appropriate manner (e.g., averaging or voting).

### 5.3 Sequential/Temporal patterns

Sequential/temporal pattern functions analyze a collection of records over a period of time for example to identify trends. The identity of a customer who made a purchase is known, an analysis can be made of the collection of related records of the same structure. Sequential pattern mining functions can be used to detect the set of customers associated with some frequent buying patterns. For example a set of insurance claims can lead to the identification of frequently occurring sequences of medical procedures applied to patients which can help identify good medical practices as well as detect some medical insurance fraud.

### 5.4 Clustering and Segmentation

Clustering and segmentation are the processes of creating a partition so that all the members of each set of the partition are similar according to some measure. A cluster is a set of objects grouped together because of their similarity or proximity. When learning is unsupervised then the system has to discover its own classes i.e. the system clusters the data in the database. Using the rules or functions can

Form the cluster.

## 6. DATA MINING ACTIVITIES AND USERS

Data mining activities are usually performed by three different classes of users: executives, end users and analysts.

€ *Executives* spend much less time with computers than the other groups.

€ *End users* are sales people, market researchers, scientists, engineers, physicians, etc

€ *Analysts* may be financial analysts, statisticians, consultants, or database designers.

These users usually perform three types of data mining activity within a corporate environment: *episodic, strategic and continuous data mining*.

In *episodic mining* we look at data from one specific episode such as a specific direct marketing campaign. Analysts usually perform episodic mining. In *strategic mining* we look at larger

sets of corporate data with the intention of gaining an overall understanding of specific measures such as profitability. In *continuous mining* we try to understand how the world has changed within a given time period and try to gain an understanding of the factors that influence change [9].

## 7. DATA MINING APPLICATIONS

Data mining has many and varied fields of application, some of which are listed below.

- € *Marketing*: Identify buying patterns from customers & Market basket analysis.
- € *Banking*: Detect patterns of fraudulent credit card use & Identify 'loyal' customers.
- € *Insurance and Health Care*: Claims analysis, Predict which customers will buy new policies & Identify fraudulent behavior.
- € *Transportation*: Determine the distribution schedules & analyze loading patterns [7].

## 8. DATA MINING PROBLEMS

As data mining discovering the hidden knowledge from the available data, it also has some problems describing below:

- € *Limited Information*: If some attributes essential to knowledge about the application domain are not present in the data it is impossible to discover significant knowledge about a given domain.
- € *Noise and missing values*: Error in either the values of attributes or class information are known as noise. We have to omit the corresponding records of missing data or average over the missing values using Bayesian techniques.
- € *Uncertainty*: Uncertainty refers to the severity of the error and the degree of noise in the data.
- € *Size, updates, and irrelevant fields*: Databases are large and dynamic & their contents are changing as information is added, modified or removed. So, it is difficult to ensure that the rules are up-to-date and consistent with the most current information.

## 9. CONCLUSION

This paper comprehensively describes various terms and techniques of data mining. Also giving the concepts regarding functions, applications and processes of Data Mining. Data Mining or Knowledge Discovery in Databases (KDD) is the nontrivial extraction of implicit, previously unknown, and useful information from data.

## 10. REFERENCES

- [1] Data mining - concept and techniques Han & Kamber
- [2] DAVID OPITZ, RICHARD MACLIN (1999). "Popular Ensemble Methods: An Empirical Study". Journal of Artificial Intelligence Research 11 (1999) 169-198.
- [3] ROBI POLIKAR, "Ensemble based system in decision making", IEEE Circuits and system magazine, Third Quarter, 2006.
- [4] NIKUNJ C. OZA, (2004). "Ensemble Data Mining Methods".
- [5] U.N.PARMAR, S.J.AGRAVAT, A.K.RANPURA, "Multiple Classifier System using Bagging Method", Jan issue 2010, IJ-ETA-ETS, international journal, Sangli.
- [6] J. R. QUINLAN, (2006). "Bagging, Boosting, and C4.5".
- [7] "Building Data Mining application for CRM" - KURT THEARLING.
- [8] URESH PARMAR, NEHA PARTIWALA, NISHIDH CHAVDA, "QUEST (Quick Unbiased Efficient Statistical Tree): An efficient algorithm of Classification Tree in Data Mining", July issue 2010, IJ-ETA-ETS, international journal, Sangli.
- [9] Data mining - practical machine learning tools and techniques, Witten

# Optimized Rumor Routing Algorithm for Wireless Sensor Networks

Zalak Modi<sup>1</sup>, Sunil jardosh<sup>2</sup>, Sunil jardosh<sup>3</sup>

1.G.H.Patel college of Eng. and Tech., Anand

2.DA-IICT, Gandhinagar

3.DA-IICT, Gandhinagar

zalak\_modi2000@yahoo.com, Email:sunil\_jardosh@daiict.ac.in,Email:prabhat\_ranjan@daiict.ac.in

**Abstract:-** *Wireless Sensor Network is data centric network that works on query reply mechanism with various types of queries. Rumor routing is of the data centric routing algorithm for Wireless Sensor Networks. Literature shows that Rumor routing algorithm is energy efficient than the Ant Colony Optimization, Gossip Routing, Deterministic Flooding and Directed Diffusion. Data centric WSN works has various types of queries that govern the traffic patterns of WSN. In our work we have exploited this key feature of Data centric WSN for improving the energy efficiency of Rumor routing algorithm. Based on information requirement, we have classified queries in two parts, instantaneous queries and continuous queries. Using this query classification we have optimized the Rumor routing for different types of traffic patterns. Our simulation result shows significant reduction in energy consumption after applying our optimization over Rumor Routing algorithm which we called Optimized Rumor Routing.*

## I. INTRODUCTION

In recent years many Network Layer protocols have been designed for routing in Wireless Sensor Networks (WSN). Karaki and Kamal in [9] gave the survey of routing protocols used in WSN. They have classified the routing protocols based on their node deployment strategy (deterministic or probabilistic), data reporting strategy (time driven, event driven, query driven or hybrid) and Energy consumption strategy without losing accuracy. Based on this survey Rumor Routing [1] can be classified as data centric kind of routing algorithm for WSN. Mainly Rumor routing algorithm is used when the geographical location of deployed nodes are unknown. For an example, randomly deployed environment monitoring network or habitat monitoring network uses Rumor routing as Network Layer routing protocol.

In WSN Data collection is divided into two parts query flooding and event flooding. Both the flooding mechanism creates energy overhead in WSN. Recent literature on WSN shows that many proposed schemes try to control query flooding and event flooding to reduce energy overhead of data collection. Rumor routing algorithm is a logical compromise between query flooding and event flooding. Ref. [4] has defined zonal rumor

routing which increases the query delivery rate by introducing zones in WSN. Ant colony algorithm [5] was used to know the behavior of the event agents or query agents, while in directional rumor routing [6] algorithm uses straight line approach instead for the random walk. Zonal rumor routing introduced by [4] shows that rumor routing is an energy efficient algorithm compared to gossip based routing, directed diffusion, Ant Colony Optimization and Deterministic Flooding. The randomized rumor routing algorithm increases the robustness of rumor routing algorithm. As shown above, literature in Rumor routing focuses on the query propagation model but they have not used the knowledge available in the query. In the paper we have used that available query knowledge to increase the efficiency of Rumor routing in data collection. To achieve this we have classified the query according to their need of information. As the traffic in network depends on the type of query generated by the network, use of available knowledge in query reduces the network traffic and gives longer network lifetime. Our proposed approach is complementary to all the suggestions proposed above and helps them further in improving the performance of network.

Rest of the paper is organized as follow. Section 2 covers working of our Query aware rumor routing protocol, section 3 covers algorithm for the different nodes and Section 4 covers our simulation results. We have concluded our paper in section 5 with discussion and future work.

## II. 2. QUERY AWARE RUMOR ROUTING

Rumor routing is a data centric routing algorithm. Such algorithms are used in networks where nodes are unaware of their geographical location. In Rumor routing, rumor is information about the event or a query for certain events, which is routed in the network. As nodes don't know the geographical location of destination or neighboring nodes, nodes transmit the information in the form of event or query agent. The node which generates the event is called the event node. Same way any node that wants to know about the event, will transmit the query agent and such a node is called the query node. In the network at the node where query agent and event agent meet each other or they both go through the path visited by each other they exchange the

information. By this they came to know about each other and thus the path is formed between event node and query node. Now the information will be passed through this path in both directions. Rumor routing is a logical compromise between event and query flooding. Following is list of terms we have use in our algorithm.

Table 1: Terms Used in Algorithm

<b>Event Agent</b>	An Event Agent is a packet that is responsible for spreading rumors about the events in the network. Each agent is associated with the time to live (TTL) that determines the number of hops that agent can traverse before it dies. An agent maintains an event list and a visited node history list.
<b>Query Agent</b>	A query is a request packet for receiving information on a particular event. Each query is associated with a time to live (TTL) that determines the number of hops the query can make. A query is considered undelivered when it does not reach its destination before the expiration of TTL. Like an event agent, a query agent also maintains a list of visited nodes or zones in a history list.
<b>Event List</b>	This list stores the event names and the distance to the events. Agents and nodes maintain their respective event lists.
<b>Neighbor List</b>	In case of Rumor Routing, neighbor list stores the node ids of the neighbors.
<b>History List</b>	In case of Rumor Routing, history list stores the node ids of the previously visited nodes. These lists maintain soft state information.
<b>Communication Range</b>	Communication range is the maximum distance that a node can send packet through wireless transmission. Therefore each node can send packet to other nodes that are within its communication range.
<b>Sensing Range</b>	This is the maximum range of each sensor node in which a sensor can detect the events. A sensor can detect multiple events occurring within its sensing range.
<b>Event path</b>	Along with spreading the rumor, the agent also constructs the event path, which is the shortest distance to the event the agent has discovered yet.

Thus the energy consumed by event node and query node for communication is  $N*V*I$ , where  $N$  is number of nodes over path

length and  $V$  is voltage needed for one node to transmit the data to the neighbor node on the path established by rumor routing and  $I$  is the drawn current.

*a) Optimized rumor routing algorithm:*

In the traditional rumor routing explained by [1], once the path is established between event node and query node, every query dispatched from query agent will go to event node for the information. In our algorithm we optimized the energy consumption of the network by using the knowledge available in query. We have classified the query in to two parts. This classification is based on the requirement of information for the particular event for which a query agent has been dispatched from a query node.

One type of the query needs the instantaneous information about an event (an over view of event) which is provided by the event agent when it meets the query agent while searching the path towards query. After that this query agent will come back to the query node. This kind of query agent does not need to go to the event node as its requirement of information is fulfilled. Total power consumed by this query is message transmission cost from query node to the meeting point of query agent and event agent. Here query need not have to go to event node so the total power consumption is lesser then the original rumor routing algorithm. Second type of agent needs the information about the event for the longer time span and asks for more information about the event. This kind of query agent will go to the event node because it needs more information about the event compared to instantaneous information oriented query agent. The query is classified before query node sends the query in the network. The result shows that the significant reduction in power consumption has achieved after applying proposed optimization technique in rumor routing algorithm on wireless sensor networks.

Let us take one simple exam suppose fire occurs at any node A, node B which is a query node needs information about the instantaneous temperature information at that node. Now for this information query agent of node B need not required to reach event node A. the information about the temperature will be available by the event agent itself. Now suppose the another query from the node B need the regular update on information about the temperature from the event node. In this case query agent requires going to the event node to make it aware of period event dispatch. This requires the same power as used in traditional Rumor routing Algorithm. In the following section we have shown the algorithms that runs our Query Nodes, Event Nodes and Intermediate Nodes.

### III. 3. ALGORITHM

In the above section gives the working principle of our optimized rumor routing algorithm. This work is complementary to the other suggested algorithms and helps in improving the performance of the rumor routing algorithm. In this section we have given the steps needed to perform at different nodes in the network.

#### A. Query Node:

Query node generates the query to get the information from network about the event. If path information about the event exists at query node then node takes next node to send query from that path, other wise they chose one of the neighboring node randomly and sends the query to that node. In the case if it receives the event information it store the path for the future use. The steps for the Query node are give below.

#### Steps for the Query Node

- 1 Set Communication Range
- 2 Set Query Frequency
- 3 Send  $k$  random Hello Packet
- 4 Wait for Neighbor Hello Packet for Predefine time
- 5 Set Query Type
- 6 Send Query Base on Query Type and Query Configuration
- 7 If Path present for event
- 8 Use neighboring node from path
- 9 Else
- 10 Select node randomly from neighbor list
- 11 Send Query with TTL
- 12 Repeat Step 8 base on Step 6
- 13 On Receive Event Agent
- 14 Get Path Information form Agent
- 15 Store information in list with purge time
- 16 On purge time Remove Entry from Query Node

#### B.

#### C. Source/Event Node:

Node that senses the environment and generative the data are called source nodes or event nodes. Event node sends the information toward the Query nodes in the event agents.

#### Steps for the Query Node

- 1 Set Communication Range
- 2 Set Event Frequency
- 3 Send  $k$  random Hello Packet
- 4 Wait for Neighbor Hello Packet for Predefine time
- 5 Set Event Type
- 6 Send Query Base on Query Type and Query Configuration
- 7 If Path present
- 8 Use next hop node from path
- 9 Else
- 10 Select Random Neighbor Node
- 11 Send Query with TTL
- 12 Repeat Step 11 base on Step 6
- 13 On Receive Event Agent
- 14 Get Path Information form Agent
- 15 Use this information for future with purge time
- 16 On purge time Remove Entry from Query Node

#### D. Intermediate Node:

Intermediate node receives the query agents and event agents and forwards them according to algorithm. In the case that node has query agent and receives the event agent it uses that information for query agent and forward the event on query path. On receiving query agent when it has related event agent it follows the same processor. In addition based on the query type it either forwards the query agent towards the event node or drops query agent and do not forward it.

#### Steps for the Intermediate Nodes

- 1 Receive the query and event agent
- 2 If only query or only event agent
- 3 Store the query and event agent
- 4 If TTL is not zero
- 5 Forward received query or event agent
- 6 Else
- 7 Drop query or event agent
- 8 Else
- 9 Forward query or event, base on received event or query information respectively
- 10 If long term query
- 11 Forward query to event node
- 12 Else
- 13 Drop query



Intelligent behavior of intermediate node based on query information helps the network to reduce the forwarded packets in the network.

#### IV. 4. RESULTS

In our simulation we have compared our query based Rumor routing algorithm with traditional Rumor routing algorithm. To compare both the protocols we have used the scalability of the network, transmission range of nodes and communication range as parameters. Algorithms are evaluated for the energy consumption requirement for different sets of parameters. In addition we have tested both the algorithms with different topological structures. For this purpose we took two topological structures one is grid and other is random node distribution. In our simulation for fix deployment region we have increased the node density per unit area, transmission range and query/event frequency and compared the standard rumor routing with our optimized rumor routing on the basis of energy consumption. In random node deployment we have assumed that for fixed power consumption per node, we are getting the connectivity which includes at least one node in its communication range.

Result in figure 1 shows the energy consumption in grid structure. Here we have increased the network size by increasing node density per unit area and analyzed the energy consumption of the network. Result shows that with optimization plotted in red line have lower energy consumption compared to without optimization shown in blue line. For random node deployment, the result is shown in figure 2.

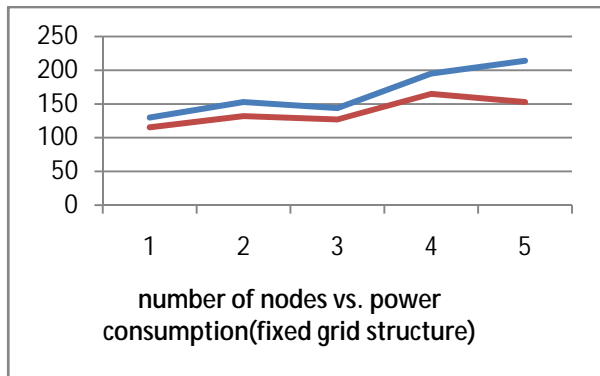

Figure 1: number of nodes vs. power consumption (fixed grid structure)

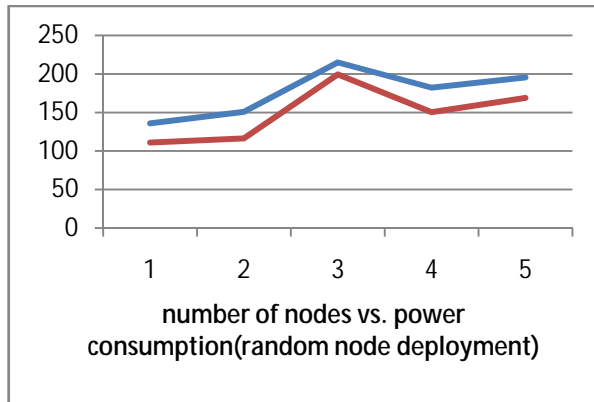

Figure 2: number of nodes vs. power consumption (random node deployment)

Here also red line shows the energy consumption due to optimized rumor routing while blue line shows the energy consumption due to traditional rumor routing. Result shows the significant reduction in energy consumption using optimized rumor routing algorithm.

The communication range is one of the parameter on which the network traffic depends on. For this query frequency is another parameter that we have used for comparing the both routing algorithms. The effect of communication on energy consumption has been evaluated both on grid as well as random structure. The figure 3 below shows the energy consumption for fixed grid structure for various communications ranges 6, 7, 8, 9, 10 and 11.

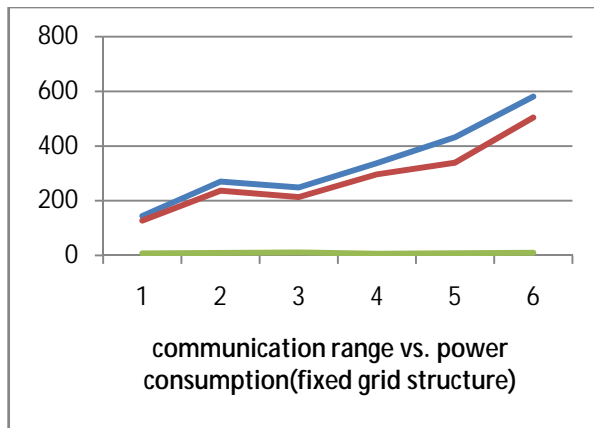

Figure 3: Communication range vs. power consumption for fixed grid structure.

For same ranges of communication we have changed the topological structure by random deployment. In both the figures red line shows the optimised rumor routing algorithm and blue line shows the traditional rumor routing algorithm.

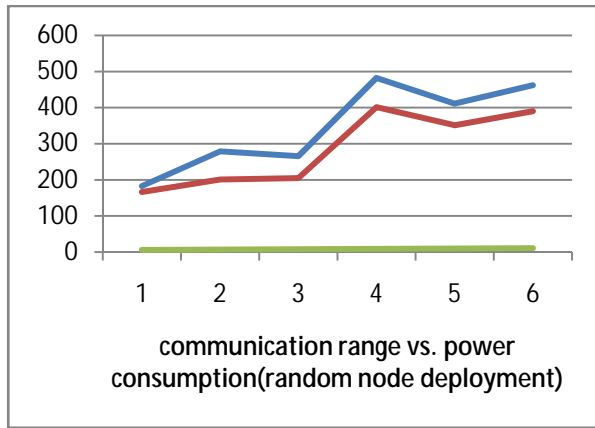

Figure 4: Communication range vs. power consumption for random node structure.

The significant improvement in energy consumption is clearly visible in all four graphs. The assumption over here is made that we can not take query node itself as event node. If we are taking a query node as event node also the results may differ.

#### Future work

We can change the query frequency (query agent per second) for single event as well as for multiple events. Also we can apply the above idea and algorithm for random and fixed grid structure.

#### V. CONCLUSION

In this paper we have proposed the query based Rumor routing algorithm which uses the information available in the query agent for the optimize routing. We have classified the query in two part instantaneous and long term queries. Based on this classification intermediate node makes their decision about the query forwarding. We have compared our algorithm with the tradition Rumor routing algorithm; simulation shows that our algorithm consumes the less energy and more energy efficient than the traditional algorithm.

#### VI. REFERENCES

- [1] Braginsky, D. and Estrin, D. 2002. Rumor routing algorithm for sensor networks. In *Proceedings of the 1st ACM international Workshop on Wireless Sensor Networks and Applications* (Atlanta, Georgia, USA, September 28 - 28, 2002). WSNA '02. ACM, New York, NY, 22-31. DOI= <http://doi.acm.org/10.1145/570738.570742>.
- [2] A. Coloni, M. Dorigo et V. Maniezzo, *Distributed Optimization by Ant Colonies, actes de la première conférence européenne sur la vie artificielle*, Paris, France, Elsevier Publishing, 134-142, 1991.
- [3] Okdem, S. and Karaboga, D. 2006. Routing in Wireless Sensor Networks Using Ant Colony Optimization. In *Proceedings of the First NASA/ESA Conference on Adaptive Hardware and Systems* (June 15 - 18, 2006). AHS. IEEE Computer Society, Washington, DC, 401-404. DOI= <http://dx.doi.org/10.1109/AHS.2006.63>
- [4] Li, X., Moaveninejad, K., and Frieder, O. 2003. Regional Gossip Routing for Wireless Ad Hoc Networks. In *Proceedings of the 28th Annual IEEE international Conference on Local Computer Networks* (October 20 - 24, 2003). LCN. IEEE Computer Society, Washington, DC, 274.
- [5] Lin, M., Marzullo, K., and Masini, S. 1999 *Gossip Versus Deterministic Flooding: Low Message Overhead and High Reliability for Broadcasting on Small Networks*. Technical Report. UMI Order Number: CS1999-0637., University of California at San Diego.
- [6] Intanagonwiwat, C., Govindan, R., and Estrin, D. 2000. Directed diffusion: a scalable and robust communication paradigm for sensor networks. In *Proceedings of the 6th Annual international Conference on Mobile Computing and Networking MobiCom '00*. ACM, New York, NY, 56-67. DOI= <http://doi.acm.org/10.1145/345910.345920>
- [7] Banka, T., Tandon, G., and Jayasumana, A. P. 2005. Zonal Rumor Routing for Wireless Sensor Networks. In *Proceedings of the international Conference on information Technology: Coding and Computing (Itcc'05) - Volume II - Volume 02* (April 04 - 06, 2005). ITCC. IEEE Computer Society, Washington, DC, 562-567. DOI= <http://dx.doi.org/10.1109/ITCC.2005.305>
- [8] Shokrzadeh, H., Mashaieki, M., Nayebi, A., Improving Directional Rumor Routing in Wireless Sensor Networks, *Conference on Innovations in Information Technology, 2007. IIT '07. 4th International* (Nov 18-20, 2007), 108-112.
- [9] Al-Karaki, J.N. Kamal, A.E., Routing techniques in wireless sensor networks: a survey, In *proceeding of IEEE Wireless Communications*, Vol 11, Issue 6, 6-28. Dec 2004.

# Fabrication of Macropore Arrays in Silicon

Mr Amit R Sharma

Asst Professor, E.C. Department, Ghandhinagar Institute of Technology, Ghandhinagar.  
amit.sharma@git.org.in

**Abstract:-The fabrication of macropore arrays in silicon by photo electrochemical etching technique in hydrofluoric acid (HF) solution is presented in this article. The formation of pore arrays with high aspect ratios by electrochemical etching of n-type silicon in hydrofluoric acid is a well established technique. The macropore morphology depends sensitively on the anodization conditions such as current density, etching time, HF concentration, light and bias voltage as well as on substrate properties such as orientation. When macroporous silicon is metallized with Nickel plating and filled with scintillating powder it acts as a waveguide for the visible light, and can improve X-ray detectors. By improving the quality of the macropores viz depth, width, flat wall, and flat bottom, one would improve the image quality of an X-ray detector.**

## 1. Introduction

This article is the result of a project in applied sensor technology at Mid Sweden University. The project is focused on the fabrication of macropores in silicon."

Fabrication of macropores by electrochemical etching in optional patterns pre determined by photo lithography has been known since 1990. The working of X ray imaging detectors is based on this photo electrochemical growth process. V.Lehmann and U. Gruning <sup>[1]</sup> etched 2µm deep pores by using a 4 n type substrate. According to them the smallest pore diameter realized so far in a regular macropore array is about .3 µm. Xavier Badel <sup>[2]</sup> achieved pore depth of 380µm, pore spacing of 30µm and wall of 3µm."

Macropores are useful in X ray imaging detector. Different parameters like temp, time, voltage, current and conc. of HF solution can vary the quality of the macropores. The macropores were plated with Ni and filled with scintillating powder Terbium doped gadolinium oxysulphide (Gd<sub>2</sub>O<sub>2</sub>S:Tb). Then this device was tested for X Ray sensitivity using dental X ray "source."

## 2. Electrochemical Etching of silicon

Electrochemical etching involves both acid and positive charged holes to dissolve the material. Silicone can be etched with hydrofluoric acid (HF), the etching rate can be controlled by adjusting the number of holes reaching the surface. One of several reactions that take place during the etching is:

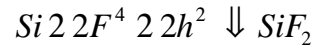

and



This uses two holes to dissolve one silicone atom. A similar reaction also takes place using four holes to dissolve one silicon atom. Other reactions are possible as there are many ions in the solution: (HF)<sup>2-</sup>, F<sup>-</sup>, OH<sup>-</sup>, F<sup>-</sup>, H<sub>3</sub>O<sup>+</sup>. Because the holes are used, new holes have to be supplied by external means. In n-type silicone holes are created by exposing the back of the wafer with light, a bias voltage move the holes to the surface of the wafer.

By measuring the current density and calculating the number of holes used during the etching, it is possible to decide which reaction is dominant. If the average number of holes used is close to two, this will result in porous etching of the silicon. Whilst if the number of holes is close to four, electro polished etching will occur. Between porous and electro polished etching there is an transition region where the current density is defined as J<sub>ps</sub>.

During etching of macropores the applied voltage will produce a "Space Charge Region"<sup>[3]</sup> that focuses the holes on to the tip of the pore, hence only at the pore tip etching will occur.



Figure 1

The current density at the pore's tip is equal to J<sub>ps</sub> and the number of holes used to dissolve a silicon atom is approximately 2.6 during macropore formation. An increase in the bias voltage will reduce the space charge region, this will increase the pore diameter and reduce the wall thickness.

### 3. Experimental process

N type, <100> orientation, 1000 cm resistance silicon wafers were taken for the experiments. Pyramids were etched with KOH form a good start for macropores

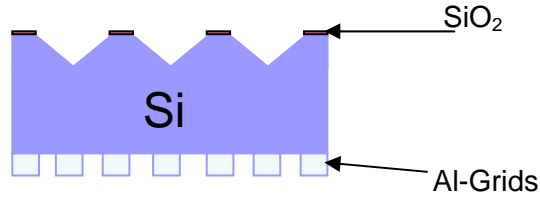

Figure 2 Cross section of a wafer

The backside of the wafer is covered with Aluminium that supplies a good electrical contact for the bias voltage. In this case a halogen lamp was used on the backside providing the holes. So a grid of aluminium is made so light can get through and create holes.

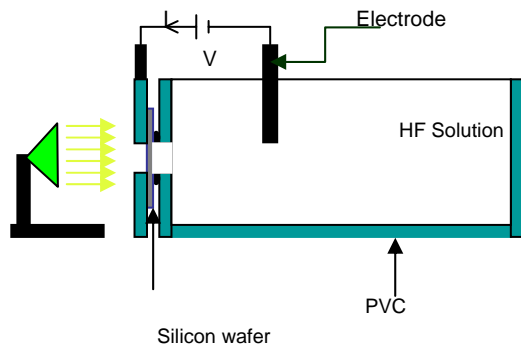

Figure 3 Experimental setup

The container is made of PVC which is resistant to HF. A platinum electrode are mounted which is used for bias voltage. The light source is located at the back side of the sample.

### 4. Equations

The HF concentration  $c$  in percentage of weight (wt% ), was calculated as follows:

$$c = \frac{1}{2} * \frac{(V_{HF\%} * \psi_{HF\%})}{V_{H_2O} * \psi_{H_2O} + 2V_{ethanol} * \psi_{ethanol} + 2V_{HF\%} * \psi_{HF\%}} \quad (\text{Eq. 1})$$

If the concentration of HF used in the experiment was 4.2 wt% then a total of 4dl solution was prepared for the experiment which includes 300ml of H<sub>2</sub>O, 100ml of ethanol and 30 ml of HF<sub>50%</sub> solution.

The critical current density in <100> N type Si wafer is calculated by:

$$J_{ps} = Cc^{3/2} * \exp(4E_a / kT) \quad (\text{Eq. 2})$$

$C = 3300A/cm^2$ ,  $c = HF \text{ conc.}$ ,  $E_a=0.345eV$  and  $k=Boltzmanns \text{ constant.}$

The pore diameter with square pores is calculated by:

$$d = p\sqrt{(J/J_{ps})} \quad (\text{Eq. 3})$$

$p=spacing \text{ of the pores}$ ,  $J=etching \text{ current.}$

If the HF concentration is changed then the  $J_{ps}$  also changes, the new  $J_{ps}$  is calculated by:

$$J_2 = J_1 \left[ \frac{c_2}{c_1} \right]^{3/2} \quad (\text{Eq. 4})$$

### 5. Metallization

The electroless Ni plating technique was used to metallize the macro porous silicon. The composition of the electroless Ni plating bath was essentially the same as that reported by S Dhar and S Chakrabarti. [4]

The temp of the bath is kept at room temp in a ultra sonic bath, and samples were kept in this solution for 10 min to 60 min.

When metallized the walls of pores acts as reflecting surface for the visible light, hence the porous silicon acts as a wave guide for the light concentrating it on the CCD.

Figure 4 SEM picture of plated pores.

## 6. Macropore arrays as X-ray detector.

In the final step of our project we filled a macropore array with scintillating powder in order to check the performance of a macropore based sensor.<sup>[2]</sup> Due to limited time it was not possible to explore this area of the project fully. Scintillating powder is used to convert X-rays into visible light that can be collected by a CCD sensor.

Digital X-ray detectors based on macropore arrays with scintillating powder serves in two ways to reduce the X ray dose, at first they increase the resolution and secondly they reduce the duration of exposure, Since some Scintillating powder require less exposure than ordinary film imaging.

The problem aroused in properly filling the macropore arrays with scintillating powder. Ultra sonic vibrators can be used as a apparatus for filling macro pores but some modification of existing apparatus is required. There is also a need for properly measuring the different parameters that will categorize the performance of device.

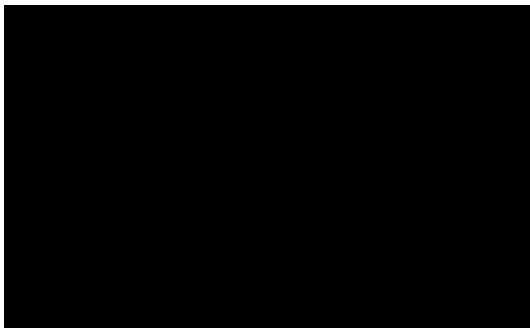
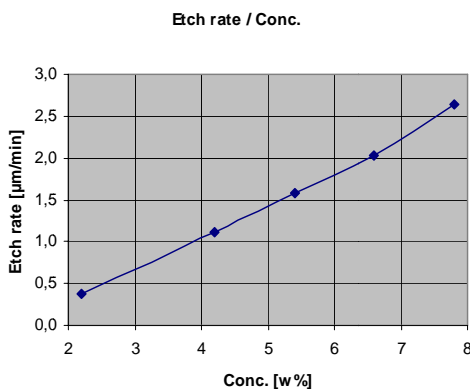

Figure 5 X-ray of an IC. The darker circle is the area with macropores that improve the contrast in the X-ray image.

## 7. Results

During electrochemical etching the number of silicon atoms dissolved is controlled by the current density. Our experimental result shows that the dept of the macropores was independent of the current applied during the etching. This is because the pore diameter is increasing when the current density is increasing according to Eq. 3. The area of the pore is equal to  $d^2$  if you have square pores. And the dept of the pores are independent of the current density.



By increasing the concentration of the HF solution the etch rate can be increased. Our experiments showed good linearity between HF concentration and reached dept.

Figure 6

Higher concentrations needs more holes and if you cant supply enough holes the wall quality may degrade. Figure 7 and 8 shows SEM images of the tip of two macropore's. In figure 8 higher concentration have been used and the current used was recalculated according to Eq. 4 to match the current in figure 7

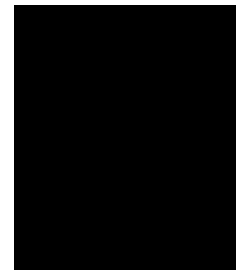
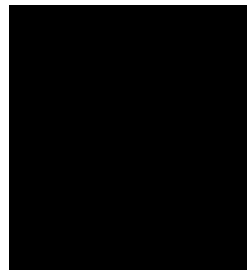

.....Figure 7.....

.....Figure 8

Figure 9 and 10 shows SEM images of pores etched with different current density. ....

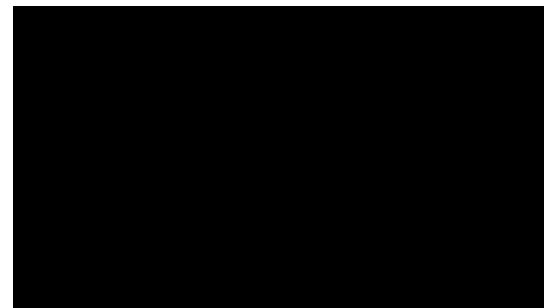

Figure 9 Current = 56mA, HF Conc = 4.2%wt, Time = 120 min

.....

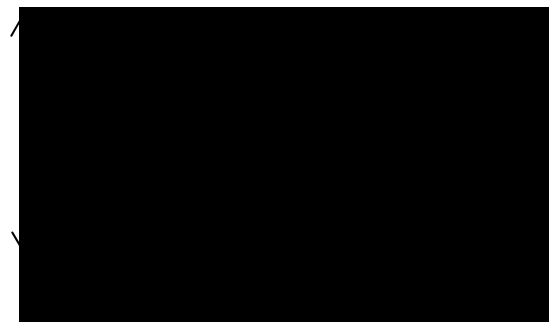

Figure 10 Current = 48mA, HF Conc = 4.2%wt, Time = 120 min

High current density led to more electro polishing which explains the flat pore bottoms and the thinner walls.

## 8. Conclusion

I successfully fabricated macropores over 310  $\mu\text{m}$  deep.

From the above experiment it can be inferred that current does not effect the etch rate. The etch rate is dependent on HF concentration. And we get deeper pores when the setup is kept for longer period of time.

The polishing of the pores depends on the current. At high current we got thin walls and flat bottoms as can be seen in figure 9.

Little time was used fore metallization and the plating process was not optimized for plating of macropores. There for the plating result was not as good as expected.

We were unable to completely fill the pores with scintillator powder. Due to limited time no effective method for filling pores were found. So the X-ray detector was not working satisfying.

## Acknowledgments

I am thankful to Göran Thungström myr teacher who gave me technical support and Henrik Andersson my supervisor for specially helping in clean room lab. I am also thankful to Mid-Sweden University for providing me with good computer and lab facilities.

## References

- [1] The limits of macropore arrays formation by V. Lehmann and U. Gruning
- [2] Development of macropore arrays in silicon and related technologies for X-ray imaging applications by Xavier Badel, KTH , Royal institute of Technology
- [3] Porous silicon – A new material for mems by V. Lehmann
- [4] Electroless Ni plating on n- and p-type porous Si for ohmic and rectifying contacts by s Dhar and S Chakrabarti.

# ANALYSIS OF MAGNETIC FLUID BASED SQUEEZE FILM BETWEEN TWO CURVED CIRCULAR PLATES

Nikhilkumar D. Abhangi<sup>1</sup>, G.M. Deheri<sup>2</sup>, Chandaniben D. Changela<sup>3</sup>

<sup>1</sup> Gandhinagar Institute of Technology, Gandhinagar, Gujarat, India,

<sup>2</sup> Department of Mathematics, Sardar Patel University, V.V.Nagar, Gujarat, India,

<sup>3</sup> Gandhinagar Institute of Technology, Gandhinagar, Gujarat, India, changela.

nikhil.abhangi@gmail.com, gmdeheri@gmail.com, [chandni@gmail.com](mailto:chandni@gmail.com)

**ABSTRACT:** Efforts have been directed to study and analyze the behavior of a magnetic-fluid-based squeeze film between curved rough circular plates when the curved upper plate (with surface determined by an hyperbolic expression) approaches the stationary curved lower plate (with surface governed by a secant function). The lubricant used is a magnetic fluid in the presence of an external magnetic field oblique to the radial axis. The associated Reynolds equation is then solved with appropriate boundary conditions to obtain the expressions for pressure and load carrying capacity. The numerically computed results are presented graphically. It is found that load carrying capacity increases with increasing magnetization. Further, it is seen clearly from the figures that the performance of the bearing system gets significantly enhanced due to the magnetization. It is observed that the load carrying capacity increases with respect to the curvature of the upper plate while a symmetric distribution takes place with regard to the lower plate's curvature parameter.. The analysis as well as the figures suggests that the bearing performance might be improved considerably by a proper choice of both curvature parameters in the presence of a magnetic fluid as lubricant. In addition this article also provides some measures to extend the life period of the bearing system.

## 1. INTRODUCTION

Murti [1] discussed the squeeze film behavior between a curved upper plate and a flat lower plate and established that the load carrying capacity rose sharply with curvature in the case of concave pads. Gupta and Vora [2] studied the corresponding problem for annular plates. In the above studies the lower plate was considered to flat one. Ajwaliya [3] analyze the problem of squeeze film behavior by modifying the approach of Gupta and Vora [2] taking the lower plate also curved. According to his investigations such situation could be found useful in design of machine elements like clutch plates and collar bearings. In all the above investigations conventional lubricants were used. Verma [4] and Bhat and Deheri [5] analyzed the squeeze film behavior between porous plates. It was concluded that the application of magnetic fluid lubricant enhanced the performance of squeeze film. However they assumed that the plates were flat. But in actual practice, the flatness of the plate does not endure owing to

elastic, thermal and uneven wear effects. With this end in view, Patel and Deheri [6] analyzed the behavior of the magnetic fluid based squeeze film between curved plates determined by secant functions. They found that the magnetic fluid lubricant improved the performance of the bearing.

Here an attempt has been made to deal with the performance of a magnetic fluid based squeeze film between a curved upper plate lying along a surface determined by hyperbolic function and a curved lower plate along the surface governed by secant function.

## 2. ANALYSIS

The configuration of the bearing is as shown in Figure 1. It is assumed that the upper plate lying along the surface given by

$$Z_u = h_0 \left( \frac{1}{12 Br} \right); 0 \leq r \leq a \quad (1)$$

Approaching the lower plate lying along the surface

$$Z_l = h_0 \left\{ \sec(4Cr^2) - 4 \right\}; 0 \leq r \leq a \quad (2)$$

with the normal velocity  $\dot{h}_0 = \frac{dh_0}{dt}$ , where  $h_0$  is the central distance between the plates, and  $B$  and  $C$  are the curvature parameters of the corresponding plates. The central film thickness  $h(r)$  then is defined by

$$h(r) = h_0 \left( \frac{1}{12 Br} - 4 \exp(4Cr^2) - 2 \right) \quad (3)$$

Assuming axially symmetric flow of the magnetic fluid between the plates under an oblique magnetic field

$$\vec{H} = H(r) \cos \pi(r, z) \hat{i} + H(r) \sin \pi(r, z) \hat{j}$$

whose magnitude  $H$  vanishes at  $r = a$ , the modified Reynolds equation governing the film pressure  $p$  is [4, 5, 6] obtained as

$$\frac{1}{r} \frac{d}{dr} \left( r h^3 \frac{d}{dr} p \right) + \frac{1}{2} \sigma_0 \bar{\sigma} H^2 = 12 \sigma \dot{h}_0 \quad (4)$$

where  $\sigma_0$  is the free space permeability,  $\bar{\sigma}$  is the magnetic susceptibility and  $\sigma$  is the fluid viscosity. Taking, for instance

$$H^2 = a(a - 4r) \quad (5)$$

and remembering that the magnetic field arises out of a potential, it can be shown that  $\pi$  the inclination angle satisfies the equation

$$\cot \pi \frac{\epsilon \pi}{\epsilon r} = 2 \frac{\epsilon \pi}{\epsilon Z} = \frac{1}{2(a - 4r)} \quad (6)$$

whose solutions are

$$C_1^2 \operatorname{cosec}^2 \pi = a - 4r \quad \text{and} \quad Z = 42 C_1 \sqrt{(a - 4r)}$$

$C_1$  being a constant of integration.

Introducing the dimensionless quantities

$$\bar{h} = \frac{h}{h_0}, \quad R = \frac{r}{a}, \quad B = Ba, \quad C = Ca^2, \quad \sigma^* = 4 \frac{\sigma_0 \bar{\sigma} h_0^3}{\sigma \dot{h}_0} \quad (7)$$

and solving the Reynolds equation (4) using Equations (3) and (5) in view of the boundary conditions

$$P(1) = 0, \quad \frac{dP}{dR} = 4 \frac{\sigma^*}{2} \quad \text{when} \quad R = 0 \quad (8)$$

(which physically mean that the pressure vanishes on the boundary of the bearing and that there is a radial flow from the axis due to magnetization), the dimensionless pressure and load carrying capacity obtained respectively form

$$P = 4 \frac{h_0^3 p}{\sigma a^2 \dot{h}_0} = \frac{\sigma^*}{2} (1 - 4R) \int_0^R \frac{R}{h^3} dR \quad (9) \quad \text{and}$$

$$\bar{W} = 4 \frac{W h_0^3}{2 \phi \sigma a^4 \dot{h}_0} = \frac{\sigma^*}{12} \int_0^1 \frac{R^3}{h^3} dR \quad (10)$$

### 3. RESULTS AND DISCUSSIONS

Expressions for dimensionless pressure  $P$  and load carrying capacity  $\bar{W}$  are presented in equation (9) and (10) respectively. From these two expressions it is clearly seen that the pressure increases by

$$\frac{\sigma^*}{2} (1 - 4R)$$

while the increase in load carrying capacity is

$$\frac{\sigma^*}{12}$$

as compared to the case of conventional lubricant.

Figures 2-3 present the variation of load carrying capacity with respect to the magnetization parameter for various values of the upper plate's curvature parameter and lower plate's curvature parameter respectively. It is clearly seen that the load carrying capacity increases significantly with increasing values of magnetization parameter. In Figures 3-4 once can visualize the effect of the curvature parameters on the load carrying capacity. The upper plate's curvature parameter increases the load carrying capacity while the lower plate's curvature parameter decreases the load carrying capacity. Further, the negative curvature of the lower plate tends to increase the load carrying capacity. Besides, the effect of  $\sigma^*$  is negligible up to the value 0.01. Further the symmetric distribution is with respect to lower plate curvature parameter (Figure 4).

### 4. CONCLUSION

This article reveals that the performance of the bearing system can be improved considerably by choosing the magnetization parameter and curvature parameters of both the plates suitably.



## 5.REFERENCES

- [1] Murti, P.R.K., Squeeze films in curved circular plates, *J.Lubr.Technology*.97 (4), p. 650, 1975.
- [2] Gupta, J.L. and Vora, K.H., Analysis of squeeze film between curved annular plates, *J. Lubr.Technology*. 102, p. 48, 1980.
- [3] Ajwaliya, M.B., Behavior of squeeze films between two curved plates, Ph.D. Thesis , S.P.University, V.V.Nagar, 1984.
- [4] Verma, P.D.S., Magnetic fluid based squeeze film, *Int. J.Engng. Sci.* 24(3), p. 395, 1986.
- [5] Bhat, M.V. and Deheri, G.M., Squeeze film behavior in porous annular discs lubricated with magnetic fluid, *Wear*, 151, p. 123, 1991.
- [6] Patel, R.M. and Deheri, G.M., Magnetic fluid based squeeze film between two curved plates lying along the surfaces determined by secant functions, *Indian Journal of Engineering & Material Sci.*,Vol. 9, February, p. 45-48,2002.

Figure: 1 Configuration of the bearing system.

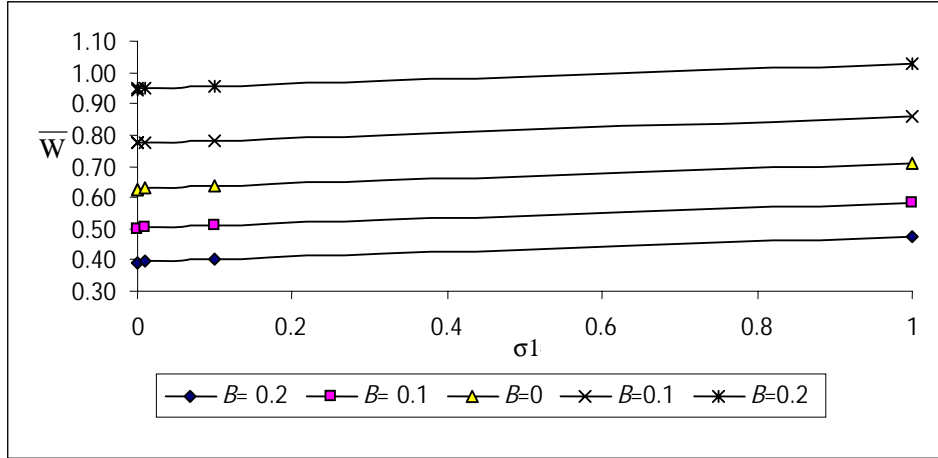

Figure: 2 Load carrying capacity with respect to  $\sigma^*$  and  $B$

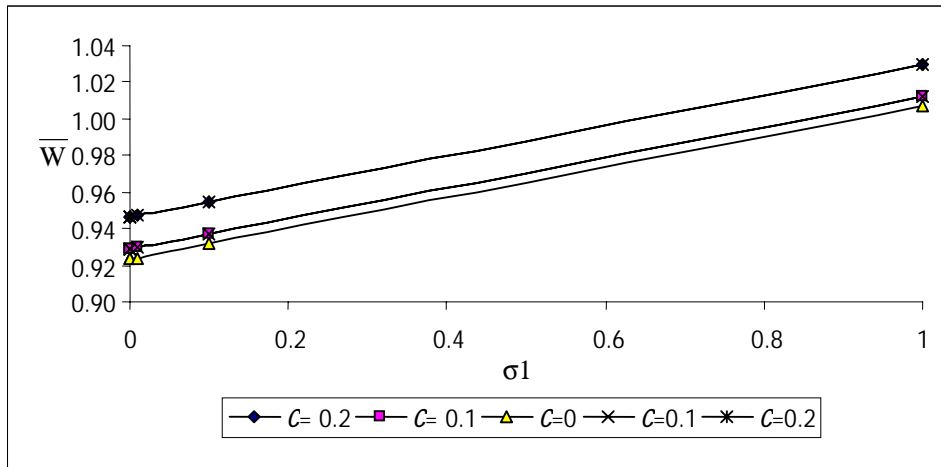

Figure: 3 Load carrying capacity with respect to  $\sigma^*$  and  $C$

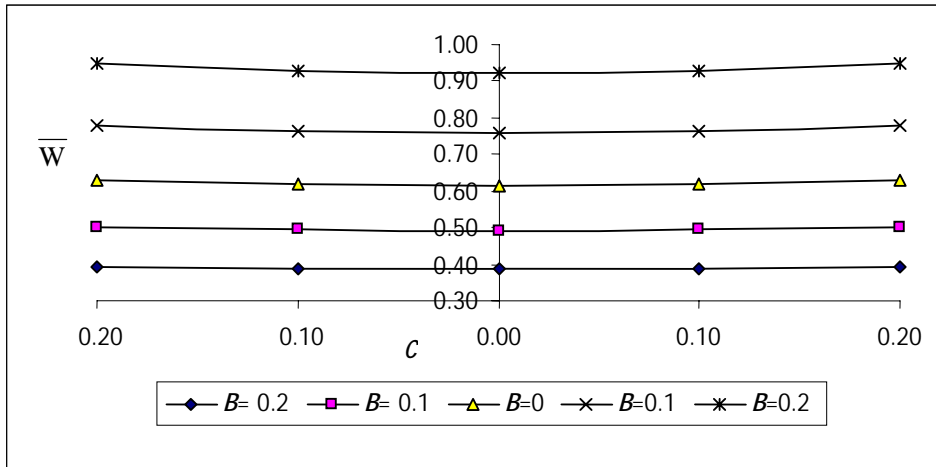

Figure: 4 Load carrying capacity with respect to  $C$  and  $B$

# APPLICATION OF SOLAR POWERED SEED SPRAYER IN AGRICULTURE – AN OVERVIEW

Milan J. Pandya <sup>1\*</sup>, Shaival R. Parikh <sup>2</sup>

<sup>1</sup> Lecturer, Mechanical Engineering Department, Gandhinagar Institute of Technology.

<sup>2</sup> Lecturer, Mechanical Engineering Department, Gandhinagar Institute of Technology.

\*Corresponding author (E-mail: milan.pandya@git.org.in)

## ABSTRACT

**This review paper deals with the design and working of “Solar Powered Seed Sprayer”. The solar seed sprayer is mainly use for agricultural purpose. It works under non-conventional energy which is the ultimate source for all living beings. The solar energy is converted into electrical with the help of solar cells. The converted electrical energy is completely stored in the battery and utilized to run a D.C. motor. Different kind of seeds can be sowed using this sprayer unit which also includes spraying solid substances and powder particles. It can be operated by a single person and is capable of covering an area of 6 hectares land in a single day.**

Key words: Solar seed sprayers, solar cell, lead acid battery, D.C. motor and hopper.

## INTRODUCTION

It is often said that food, clothing and shelter are the three basic needs of man kind. All the above three are based on agriculture. Agriculture is known to our people for thousands of years. But still our farmers in the villages are using only old-age technology. The population in our country has increased at least 3 times since our independence. The agricultural land has diminished in size and these lands have been diverted for industrial and domestic purposes.

For improving the productivity of our agricultural lands, it is stressed that they might employ high technology in every activity. Hence it will be in the fitness of things to design a device which can be operated annually. Therefore the idea of solar

powered seed sprayer becomes very helpful. Agriculture starts with sowing of seeds and fertilizers

and this particular activity have to carry out several times.

Hence if manually operated sprayer is designed it will prove to be a small but very effective step for achieving a high potential in growth.

## € *Solar Energy – A Boon to Mankind.*

Solar radiation is among the promising new source of energy. India receives annually over 60 x 1000 MWH of solar radiations with a span of 3000 – 3200 hrs. in Rajasthan, Gujarat, West of Madhya Pradesh and North of Maharashtra. Also around 2600 – 2800 hrs in the rest of the country excepting Kerala, Assam and Kashmir. Energy from the sun can be utilized in multi-various ways. It can be tapped directly from solar radiation in the form of thermal, thermodynamic and photo voltaic energy and indirectly through other related sources like wind, hydro power and ocean energy available on the planet Earth. The contribution of these sources in the total consumption of energy in the world is about 15 % only.

Traditionally, the utilization of solar energy has been confined to drying of agricultural products such as grains, maize, paddy, ginger, cashew, pepper, tobacco, fish and food drying. Its commercial application has been limited to production of common salt and other marine chemicals like potash, cromide and magnesium salts.

### Applications of Solar Technology.

- Ø Solar water heating
- Ø Space heating
- Ø Space cooling
- Ø Solar energy – thermal electric conversion
- Ø Solar energy – photo voltaic electric conversion
- Ø Solar distillation
- Ø Solar pumping
- Ø Agriculture and industrial process heating
- Ø Solar furnace
- Ø Solar cooking
- Ø Solar production of hydrogen
- Ø Solar green houses and the list goes on.

### DIRECT UTILIZATION OF SOLAR ENERGY

The most useful way of harnessing solar energy is by directly converting it into electricity by means of solar photo – voltaic cells. Sunshine is incident on Solar cells. In this system of energy conversion, direct conversion of solar radiations into electricity is carried out.

In recent year's photo – voltaic power generation has been receiving considerable attention as one of the more promising energy alternatives. The reason for this rising interest lies in PV's direct conversion of sunlight to electricity. The non polluting nature of the PV has increased its use considerably. Hence forth the low cost of conventional energy sunlight has obviated the development of a broad – based PV technology. At the present time, the PV generation can be justified only for special situations mostly for remote sites where utility lines on other conventional means of furnishing energy may be comparatively expensive and is one of the most attractive non-conventional energy sources of proven reliability from the micro to the mega watt level.

Like other energy system, this particular system also has some disadvantages.

1. Distributed nature of solar energy.
2. Absence of energy storage.
3. Relatively high capital cost.

### DESIGN OF SOLAR POWERED SEED SPRAYER

The design of the seed sprayer operated by the solar energy is very simple and also requires less operating cost. The following are the main components of the seed sprayer device.

1. Solar panel
2. Panel stand
3. Connecting wire

4. D.C. motor
5. Blower
6. Battery
7. Hose
8. Seeds
9. Hooper
10. Adjustable screw
11. Seed splitter

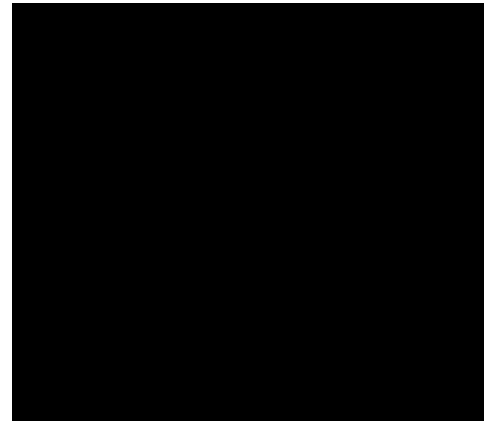

**Fig. 1.0 Design of solar powered seed sprayer**

The functions of the different components are as follows:-

#### 1. Solar panel.

The photo voltaic effect can be observed in nature in a variety of materials that have shown the best performance in sunlight. When the photons from the sun are absorbed in a semi conductor, that create free electrons with higher energies than the created, there must be an electric field to induce these higher energy electrons to flow out of the semi – conductor to do the useful work. A junction of materials which have different electrical properties provides the electric field in most solar cells.



**Fig. 2.0 Basic components of a photo voltaic cell**

## 2. Panel stand

It is used for providing the platform to the panel of the photo voltaic cells. It is made from mild steel material.

## 3. Connecting wire

It just transfers the current generated by the solar cells to the battery.

## 4. D.C. motor

A 12 V D.C. motor is used is used to run the blower fan. It runs with the help of the current supplied by the battery.



**Fig. 3.0 Exploded view of a D.C. brushless motor**

## 5. Blower

It is just used for providing the necessary force for the spraying of the seed or fertilizers.

## 6. Battery

The function of the battery is to provide current to the D.C. motor fro its effective running. The battery used in the device is the lead – acid battery. The positive and negative electrodes of a lead acid battery are immersed in dilute sulphuric acid. Then the battery is fully charged, there is lead peroxide on the positive plate and the spongy lead on the negative plate as the active materials.

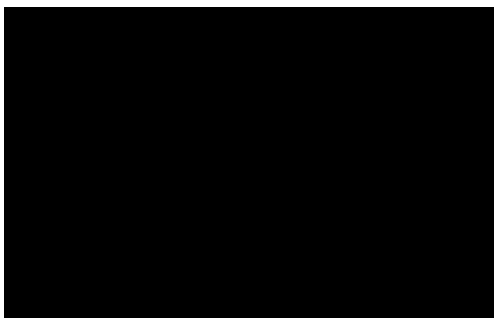

**Fig. 3.0 Exploded view of a general battery**

## 7. Hose

It is used for the connection purposes.

## 8. Hooper

It is a funnel – shaped device where the seeds or fertilizers to be sprayed are stored.

## 9. Adjustable screw

When the speed of the seeds sprayed is to be increased or decreased, it is done with the help of the adjustable screw fitted on the lower part of the hopper.

## 10. Seed splitter

It is the device through which the seeds are sprayed to a particular destination.

## WORKING OF SOLAR POWERED SEED SPRAYER

The blower fan is made to rotate by using a 12 V D.C. motor. The supply of the current is been given from the 12 V lead – acid battery provided. The chemical liquid (seeds or fertilizers) provided in the hooper may reach the nose for the spray by the gravitational force. The panel of photo voltaic cells is fixed by providing the M.S. plates. During the sunshine, the panel board absorbs the heat energy from the sun and it converts it to the electrical energy and sends these current to the battery for the storage provision. The stored energy from the battery is supplied to the motor for operating the blower fan. The discharge of the electrical energy from the battery will be equal to the charging of the battery by the solar photo voltaic cell.

## ADVANTAGES

- Ø Since the efficiency of the sprayer is very high, it can be used by the farmers.
- Ø The materials spread uniformly.
- Ø This device is portable.
- Ø It is light in weight.
- Ø Unskilled workers can also operate it effectively.
- Ø Low operating and maintenance cost.
- Ø This device works on non - conventional energy source (i.e. Sun).
- Ø Maintenance in comparatively easy.
- Ø This device is pollution free as there is no combustion of fuel.
- Ø This device can be used for small and large scale.

## **CONCLUSION**

Today as we are facing the problems of the Global Warming, the concept of the Solar operated Seed Sprayer gives a good alternative for future use. Also this device is much useful in the agricultural countries like India. This device is simple and can be easily operated. Also the results have proved that the working of this sprayer is quite satisfactory for most of the seeds and fertilizers to be sprayed very frequently. Moreover the device can also be modified as per the requirements of the demand by changing the motor and battery capacity. Further developments can also be done in the design of the seed sprayer for increasing the efficiency of the sprayer.

## **REFERENCES**

- [1] C.P. Malik, S.K. Thind and D.S. Bhatia, "Alternating plant archetype with plant growth regulators", Agro's Annual Report of Plant 36 (4), 1995.
- [2] K.K.G. Menon and H.C. Srivastava, "Increasing plant productivity through improved production techniques", 1984.
- [3] C.P. Malik, U. Parmar, P. Singh, K.L. Ahuja and R.K. Raheja, "Henolic acid and aliphatic growth and oil production", Plant Growth Regulation Report – 2, 1985.
- [4] G.D. Rai, "Non – conventional sources of energy".
- [5] Aggrawal, "Solar Energy" an article.
- [6] S.K. Bose, "Solar Energy" an article.

# SOME ASPECTS RELATED TO FLOW SYSTEM TEST AND TURBOMACHINE SELECTION

**Mahesh J. Zinzuvadia,**  
B V M Engg. College,  
Dist. Anand, State- Gujarat,  
VALLABH VIDYANAGAR- 388120

## ABSTRACT

Many industrial applications use combination of Flow system and turbomachine to maintain required fluid flow rate. In these applications power consumption can be minimized by selecting appropriate turbomachine. In this paper, two Flow Systems are tested and potential uses of test results for prediction of Flow system characteristics and in selection of appropriate turbomachine are discussed.

## Introduction

Power consuming fluid machines like pump, blower and fans are required to maintain flow through pipeline, duct or device. Here system made up by using pipeline, fittings and devices is known as Flow system and it is fitted externally with fluid machine.

## CHARACTERISTICS OF FLOW SYSTEM AND OPERATING POINT:

When fluid flows through the Flow system, head loss takes place. The head loss of the Flow system is there due to head loss given by all components of the Flow system. Head loss given by Flow system is also known as its resistance and for given Flow system it depends upon the flowrate through the system. The relationship between flowrate and resistance of Flow system is known as characteristic of flow system[1].

Characteristic of given Flow system can be obtained either analytically or by experimental method. Analytical method is used for simple duct-like system only, while experimental method is used for Flow systems having more complexity. In experimental method, head loss of the Flow system is calculated by using measured values head at inlet and outlet of the Flow system at different flowrates. As resistance of Flow system is proportional to square of flowrate, system characteristic curve will be parabolic.(Fig.1)

When flow system is connected with any power consuming turbomachine, pressure developed by turbomachine should be same as pressure drop of the flow system. This condition is satisfied at Operating point of machine-system combination. Thus operating point is point of intersection of Flow system characteristic and turbomachine characteristic(Fig.1).

Operating point of the machine-system combination may or may not coincide with best efficiency point(b e p).When appropriate turbomachine is selected, Operating point will coincide with b e p and turbomachine will consume minimum power while maintaining required flowrate[2].

## EXPERIMENTAL SET UP AND RESULTS:

The tests were carried out on a Flow system comprising of pipeline, valve and nozzle. Flow system was fitted at blower outlet and flowrate through the Flow system was varied by partial closing of blower inlet in steps. Total head at Flow system inlet and that at Flow system outlet were measured by Prandtl's pitot tube at different flowrates. From the observations resistance of the flow system and flowrate were calculated to obtain Flow system characteristic. Different openings of valve give different flow systems and two such Flow systems were tested. Fig.2 shows experimental results graphically.





## **DISCUSSION AND CONCLUSION:**

When different Flow systems are obtained by different valve openings, experimental testing can be replaced by suitable method of prediction also. The results obtained here are useful to find accuracy of predicted results.

Characteristics of Flow systems shown in Fig.2 are useful to select appropriate turbomachine to maintain required flowrate. Steps of selection procedure will be as below:

- (1) Obtain system characteristic curve of given Flow system experimentally.
- (2) Considering the application, find required value of flowrate ( $Q_1$ ), e.g. for air-conditioning application, cooling requirement gives necessary air flowrate.
- (3) Find resistance ( $R_1$ ) corresponding to flowrate ( $Q_1$ ) from system characteristic Curve.(Fig.1)
- (4) Select the turbomachine, which has flowrate of  $Q_1$  m<sup>3</sup>/s and head equal to  $R_1$  m at Design point of turbomachine..

## **REFERENCES**

- [1] Essentials of Engineering Fluid Mechanics, Fourth Edition, pp.493-495.  
Reuben M. Olson.
- [2] Introduction to Fluid Mechanics, Fifth Edition, pp.531-540  
Robert W. Fox and Alen T. McDonald.

[Cdqw"Wu](#)

[Gf kvqtken"Dqctf](#)

[IKV"Vtwuyggu](#)

[Gf kvqtken"IKV"LGV](#)

[Oguucig](#)

[Eqpvgpv](#)

[Eqpvcev"Wu](#)

## Eqpvcev"WU

Cfftguu<

Icpfjkpcict"Kpuvkvwyg"qh"Vgejppnqi {  
Mjcvctcl/"Menqn"Tqcf.  
Xkncig"OqvkJjq{cp.  
Ven0"Menqn  
Icpfjkpcict/5:4943

Vnggrjqpg"Pq"<

- ;3/24986/4:3:82  
- ;3/24986/4:3:83

G/o ckn<"fktgevqt B ikv0qt i0kp

Hcz<

- ;3/24986/4:3:84